



*“Stronger in the Storm”™*

**CHECK  
OUT OUR  
NEW  
PRODUCTS!**

# PRODUCT CATALOG SPRING 2026 DIVISION 3, 4 AND 6



**WOOD, SEISMIC, AND MASONRY TIE-DOWN SYSTEMS AND CONSTRUCTION CONNECTORS**

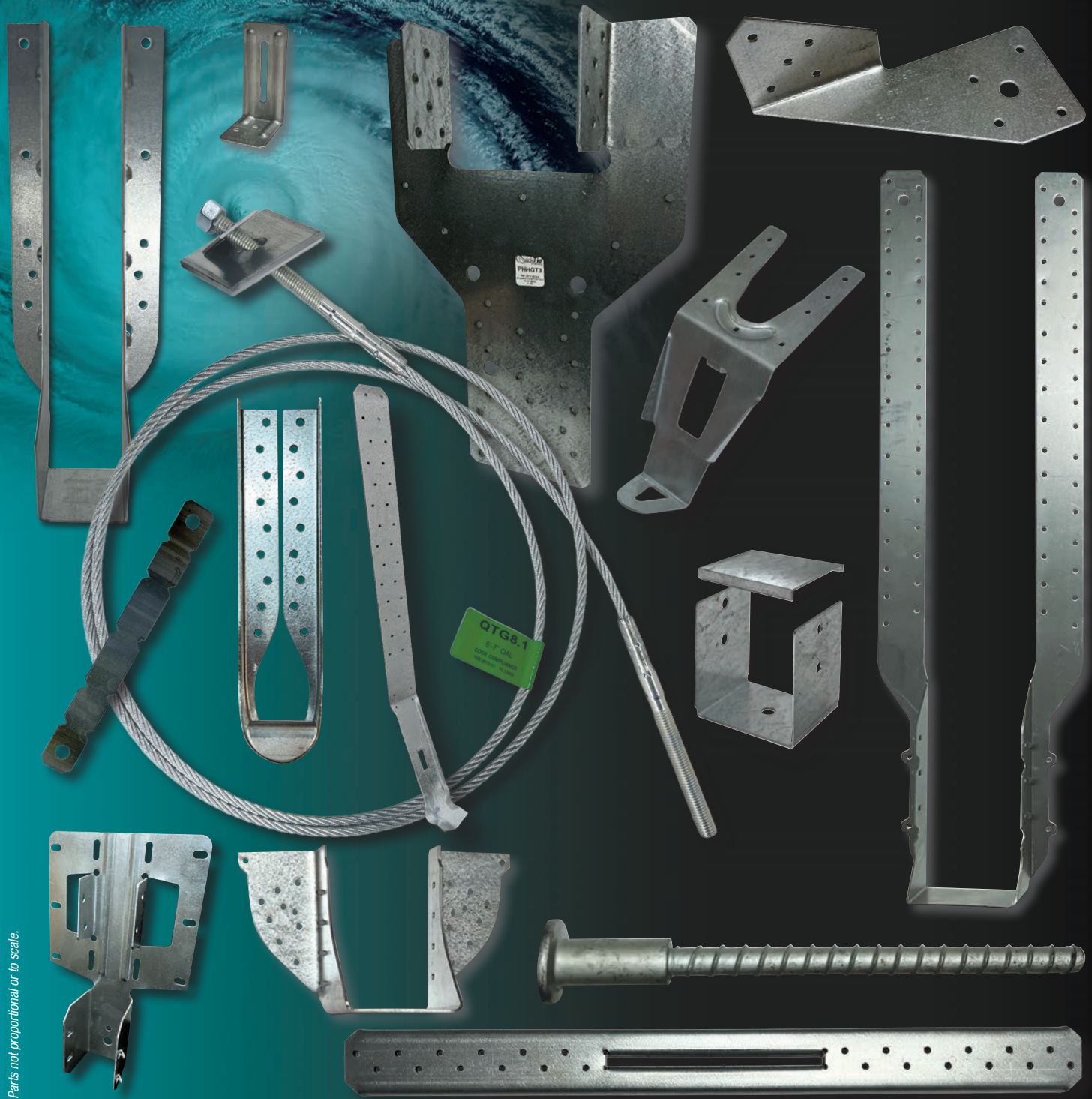

Parts not proportional or to scale.



Main Office: 13300 Vantage Way | Jacksonville, FL 32218 | (904) 281-0525 | To Order: [orders@quicktieproducts.com](mailto:orders@quicktieproducts.com) | [quicktie.com](http://quicktie.com)

**QUICK TIE PRODUCTS, INC. | PRODUCT CATALOG | SPRING 2026**

# QUICKTIE™ CUTTING-EDGE PRODUCTION CAPABILITIES

CALL FOR  
BOX, TRUCK &  
PALLET PRICING



EASY  
ORDERING

SINGLE-FAMILY QUOTE: [orders@quicktieproducts.com](mailto:orders@quicktieproducts.com)

MULTI-FAMILY QUOTE: [estimating@quicktieproducts.com](mailto:estimating@quicktieproducts.com)

GENERAL INQUIRY: [info@quicktieproducts.com](mailto:info@quicktieproducts.com)



CUSTOM PARTS  
TO ORDER

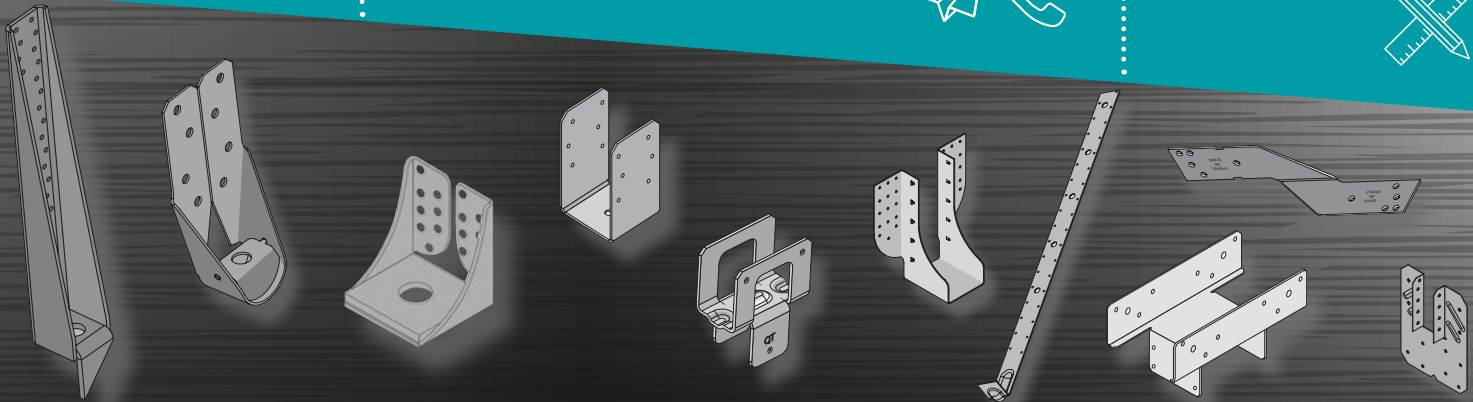

Founded in 1999, Quick Tie Products, Inc. has been protecting homes and their residents for 26 years. We run a state-of-the-art production manufacturing facility equipped with advanced machinery, and have in-house engineering and design as well as tool and die capabilities. We specialize in designing and manufacturing a wide range of structural components for single and multi-family structures like QuickTie™ Cables, Holdowns, Truss to Top Plate Connectors, Straps, Hangers, Foundation Connectors and more, all in Jacksonville, Florida USA. ***\*Select certain components (wire rope, wood screws, threaded rod and epoxy), may be sourced internationally. Product-specific origin information is available upon request.***

[quicktie.com](http://quicktie.com)

**QuickTie™**  
HIGH WIND AND SEISMIC SYSTEMS

**“Stronger in the Storm”™**



Scan to Learn More

13300 Vantage Way  
Jacksonville, FL 32218  
Phone: (904) 281-0525  
[info@quicktieproducts.com](mailto:info@quicktieproducts.com)

## About Quick Tie Products, Inc.

Since 1999, Quick Tie Products, Inc. ("QuickTie™") has manufactured and distributed an engineered system for residential construction that withstands hurricane force winds and meets building codes. It is a preferred choice of structural engineers and building professionals for a variety of reasons – two of which are its tattletale nature and the ease of inspection. QuickTie™ cables are tensioned over the specified design load at installation, gradually relaxing. If the system were to fail, it would fail at installation under peak stress. Over-tensioning also compensates for wood shrinkage and cinches a structure to its foundation while reducing drywall cracks and nail pops. And QuickTie™ cable anchor embedment depth is 100% verifiable (compared to threaded rod-based systems where depth is completely unverifiable absent a slab x-ray).

Given the choice between threaded rod, conventional hold-down and the QuickTie™ cable system, installers overwhelmingly prefer our system to save material conveyance and installation time – and therefore – money. This is particularly true on multistory structures where the cost-conscious engineers and their construction partners heavily favor QuickTie™ cables over the other options.

QuickTie™ also manufactures virtually every other structural component needed to build a light wood frame or CMU building. The staff of Professional Engineers and designers would love the opportunity to introduce you to their products. Visit [quicktie.com](http://quicktie.com) for more information.

### CUSTOM PARTS

Please contact us about manufacturing your custom steel parts (such as custom hangers, plates, etc.). We are happy to design a part unique to your situation, or, manufacture products to your design, with as little as a 48 hour turn-around time.



## Warranty

Quick Tie Products, Inc. warrants that, after reasonable notice in writing delivered to its corporate office at 13300 Vantage Way, Jacksonville, FL 32218, from the date of purchase and for a period of one year, and after reasonable opportunity to inspect, it will replace without charge, any product manufactured by QuickTie™ which, upon inspection, is found by QuickTie™ to have been defective at the time of delivery by QuickTie™. This warranty does not apply if the claim is made more than one year from the date of purchase, or, in the event the products have been altered, damaged, installed improperly or misused in any manner after delivery by QuickTie™. This remedy shall constitute QuickTie's sole obligation and purchaser's sole remedy under this warranty. In no event will QuickTie™ be responsible for incidental, consequential, or special losses or damage regardless of cause. All warranties are void on products installed with epoxies that either (a) are not sold by QuickTie™ or (b) do not carry the QuickTie™ label.

Products sold, but not manufactured, by QuickTie™ shall be subject to the warranties and conditions thereof of the respective manufacturers. There are no warranties which extend beyond the description on the face hereof, and the warranty described in this paragraph shall be in lieu of any other warranty, expressed or implied, including but not limited to any implied warranties of merchantability, fitness for a particular purpose, course of dealing or usage of trade, all such other warranties being hereby expressly excluded.



### Quick Tie Products, Inc. Affiliations or Memberships



## Stronger than Hurricane Michael

The QuickTie™ System proved its importance and durability during Hurricane Michael in Mexico Beach by sustaining 165 mph winds. This was the first Category 5 hurricane on record to impact the Florida Panhandle, and the fourth strongest landfalling hurricane in the contiguous United States.



at Mexico Beach, FL



View Video

PRODUCT	PAGE NO.	PRODUCT	PAGE NO.	PRODUCT	PAGE NO.
<b>INTRODUCTION</b>		<b>QUICKTIE™ CABLES</b>		<b>Post Caps</b>	
About QuickTie Products, Inc.	3	QuickTie™ Wood Installation	30	PCM/EPCM	53
Warranty	3	<b>Wood Frame QuickTie™ Cables</b>		CCS/ECCS	54-55
<b>CODE EVALUATIONS</b>		QTB	31	PCS/PCES	55
Product Testing and Approvals	11	QTG	31	<b>Nail Protection Plates</b>	56
General Product Information	12	QTO	31	<b>Tension Compression Straps</b>	
Adjustment Factors for		QTR	31	TCS	56
Alternate Fasteners	13	<b>About QuickTie™ Cables (QT)</b>	32	<b>JOIST &amp; GIRDER HANGERS</b>	
<b>FOUNDATION CONNECTORS</b>		Uplift Spacing Table	33	<b>Top Mount Joist Hangers</b>	
<b>Concrete and Masonry Anchors</b>		Typical Wood Installation	34	TFLP/TFH Hangers	57
SPArtan® Sill Plate Anchor	15	Combined Tension & Shear	34	TFHD Hangers	57
Anchor Chair	16	QT Beam Connector	35	TFHBH Hangers	58
Anchor Bolt	16	Compression Stud Details	36	<b>Face Mount Girder Hangers</b>	58
Anchor Bolt Assembly	17	QT Typical Multi-Story Installation	37	<b>Face Mount Hangers</b>	
CMU Saddle Assembly	17	QuickTie™ Column Details	38	UL Series	59-62
Epoxy Anchors	17	QuickTie™ Portal Frame Details	39	ULP & ULP-IF Series	59-62
Form Tie & Form Tie-Shot	18	<b>QuickTie™ Masonry Installation</b>	40	UM Series	59-62
<b>Wall Ties</b>	19	<b>Masonry QuickTie™ Cables</b>		UH & UH-IF Series	59-62
<b>Foundation Anchor Strap</b>		QTBM	41	<b>TRUSS HANGERS</b>	
FASA	19	QTGM	41	<b>Truss Strap Hangers</b>	
<b>Foundation Strap-Tie Holdowns</b>		QTOM	41	TSH Series	63
FSTHD	20	QTRM	41	<b>Truss Hip-Jack Hangers</b>	
<b>Post Base Anchors</b>		Typical Masonry Installation	42	THJH Series	64
Porch Post Base (PBA-P)	20	QTMS – PVC Sleeve	42	<b>Skewed Truss/Joist Hangers</b>	
Post Base (PBA)	21	<b>WOOD CONNECTORS</b>		UMSR/L Series	65
<b>Holdowns</b>		<b>Hurricane Anchors &amp; Twist Straps</b>		UHSR/L Series	65
LTT20	22	HA4		<b>Truss/Joist Heavy Hangers</b>	
HDTT	22	HA6		UMH Series	66-67
HDTT3	22	HA8		UHH Series	66-67
HDTT6	22	HA10		UHD Series	66-67
HD5	22	QGC & QGCW		<b>TRUSS CONNECTORS</b>	
HD7	23	LTS-3Z		<b>Tension-Compression Connectors</b>	
HD8	23	MTS-3Z		TCC	68
HD11	23	HTS-3Z		<b>Truss Clips</b>	
HD14	23	<b>Stud Plate Ties</b>		TR	68
HD22	23	RSPT		<b>Post Install Girder Tie Downs</b>	
<b>Purlin Anchor Straps</b>		SPT & SPTH		PHGT	69
PAS Series	24	<b>Hurricane Gusset Angles</b>		PHHGT	69
METAS/HETAS Series	25	HGA		<b>Slopeable/Skewable Hangers</b>	
<b>QUICKTIE™ ACCESSORIES</b>		HGAM		ULPSSH	69
<b>Epoxy Adhesive &amp; Accessories</b>		<b>Deck Tension Tie</b>		<b>Corner Hip Plates</b>	
QuickTie™ Epoxy	26	Shear Clips/Flats		CHP	70
QuickTie™ Epoxy Dispensing Tool	26	SC34		<b>Jack Truss Connectors</b>	
Cleanout Brush	26	SC35		JTC	70
QE-1 Allowable Loads	26	SC35F		<b>SCREWS</b>	
<b>Hardware</b>		<b>Plywood Clips</b>		<b>Wood Screws</b>	
Threaded Rods	27	Flat Straps		Hex Head	71-72
Hex & Weld Nuts	27	LS		Flat Head	71-72
Couplers & Reducer Couplers	27	MS		Fillister Head	71-72
Bearing Plates/Washers	28-29	<b>Coil Strapping</b>		Truss/Stud	71-72
<b>Fire Caulk</b>	29	CS		<b>Truss to Plate Connection (SWT)</b>	73
		CMST		<b>Deck Ledger to Stud Attachment (SWH)</b>	74

# QuickTie™ Product Index

Below is the QuickTie™ product index, noting product categories, QuickTie™ part numbers, catalog page numbers, and certain “Reference Numbers”. References Numbers are also displayed in the load tables for Holdowns (page 23) and Face Mount Joist/Truss Hangers (pages 60-62, 66-67).

These Reference Numbers are for the purpose of enabling our customers to identify the QuickTie™ alternative to specified product names, but the attributes of the products references (particularly load values) may differ from the QuickTie™ part.

Please note that product comparison via Reference Numbers is for general application comparison only. Reference Numbers should not be used as an apples-to-apples substitution tool. Customers are solely responsible for comparing specific load values, fastener schedules, anchoring requirements, material specifications, and other factors when determining the suitability of use of any particular product. QuickTie™ makes no claim, stated or implied, of suitability for purpose or qualification for usage of our products that may be substituted for a specified product. Any specification, submittal, or change to a specified product should be approved in writing by the designer or Engineer of Record (EOR).

MiTek® and Simpson Strong-Tie® are registered trademarks of their respective companies, with which QuickTie™ is unaffiliated, and neither of whom endorse or approve use of their product names in this catalog as “reference numbers”.

QT Products	QT	Reference Numbers		Page
		Simpson® Hardware (SH)	MiTek® Hardware (MH)	
SPArten Sill Plate Anchor	SPA67	THD	PFM	15
Anchor Chair	AC33	ABL	ARC	17
Anchor Bolt	ABG	PAB	AB	
	ABO	SB		
	ABR	-		
Anchor Bolt Assembly	QTABA	AM	-	17
CMU Saddle Assembly	CMUB	-	-	
	CMUG			
	CMUO			
	CMUR			
Epoxy Anchors	EA	THD	PFM	18
Form Tie/Form Tie-Shot/Form Wedge	FT8/FW	-	-	
	FT6/FT6S			
Wall Ties	WT10	-	-	19
	WT6-8	-	-	
Foundation Anchor Strap	FASA4	MASA, MASAZ	FA4, FA4-TZ	19
Foundation Strap-Tie Holdowns	FSTHD8	LSTHD8	LSTAD8	20
	FSTHD8J	LSTHD8J	LSTAD8RJ	
	FSTHD10	STHD10	STAD10	
	FSTHD10J	STHD10RJ	STAD10RJ	
	FSTHD14	STHD14	STAD14	
	FSTHD14J	STHD14RJ	STAD14RJ	
Post Bases	PBA44	FA4, FA4-TZ	PAU44, PAU44-TZ	20
	PBA44R	ABU44RZ	-	
	PBA46	ABU46, ABU46Z	PAU46, PAU46-TZ	
	PBA46R	ABU46RZ	-	
	PBA66	ABU66, ABU66Z	PAU66, PAU66-TZ	
	PBA66R	ABU66RZ	PAU66R-TZ	
	PBA77	ABW7-7Z	-	
	PBA88	ABU88, ABU88Z	PAU88, PAU88-TZ	
	PBA88R	ABU88RZ	PAU88R-TZ	
	PBA1010	ABU1010Z	PAU1010-TZ	
	PBA1010R	ABU1010RZ	PAU1010R-TZ	
	PBA1212	ABU1212Z	PAU1212-TZ	
	PBA1212R	AABU1212RZ	PAU1212R-TZ	
Porch Post Bases	PBA44-4P	PPB44-4Z	-	20
	PBA44-6P	PPB44-6Z	-	
	PBA66-4P	PPB66-4Z	-	
	PBA66-6P	PPB66-6Z	-	
Holdowns	LTT20	LTT20B	LTS20B	23
	HDTT	DTT2Z, DTT2Z-SDS2.5	DTB-TZ	
	HDTT3	HU2-SDS2.5, HD3B	PHD2A, TDX2-TZ	
	HDTT6	HTT4, HTT5, HDUE3-SDS3	HTT45	
	HD5	HU4-SDS2.5	PHD4A	
	HD7	HU5-SDS2.5, HDUE5-SDS3	PHD5A	
	HD8	HU8-SDS2.5, HDUE7-SDS3	PHD8	
	HD11	HDQ8-SDS3, HDU11-SDS2.5, HHQ11-SDS2.5, HDUE9-SDS3	UPHD8, UPHD9	
	HD14	HHQ14-SDS2.5, HDUE13-SDS3	-	
	HD22	HD19, HDU14-SDS2.5, HDUE17-SDS3	TD15, UPHD11, UPHD14	

Foundation Connectors

QT Products	QT	Reference Numbers		Page
		Simpson® Hardware (SH)	MiTek® Hardware (MH)	
Purlin Anchor Straps	PAS18-3Z	PA18, PA18Z	PA18, PA18-TZ	24
	PAS23-3Z	PA23, PA23Z	PA23, PA23-TZ	
	PAS28-3Z	PA28, PA28Z	PA28, PA28-TZ	
	PAS35-3Z	PA35, PA35Z	PA35	
	PAS51-3Z	PA51, PA51Z	TA51, TA51-TZ	
Embedded Truss Straps	METAS12-3Z	META12	HTA16-18	25
	METAS16-3Z	META16	HTA16-18	
	METAS18-3Z	META18	HTA20-18	
	METAS20-3Z	META20, META20Z	HTA20-18, HTA20-TZ	
	METAS24-3Z	META24	HTA24-18	
	METAS40-3Z	META40	HTA48	
	HETAS12-3Z	HETA12	HTA12	
	HETAS16-3Z	HETA16	HTA16	
	HETAS20-3Z	HETA20, HETA20Z	HTA20, HTA20-TZ	
	HETAS24-3Z	HETA24	HTA24	
HETAS40-3Z	HETA40	HTA48		
Epoxy	QE-1	SET-3G	CIA-GEL 7000-C	26
		SET-XP	CIA-GEL 7000	
		ET-HP	-	
		SET	-	
		AT-XP	-	
Threaded Rods	TR	ATS-R	ATR	27
		ATS-HSR		
Hex Nuts	HN, HHN	NUT	HN	27
Weld Nuts	WN	-	-	
Couplers	C	CNW	CNW	28
Reducer Couplers	CR	HSCNW	-	
Bearing Plates / Washers	BPW	BP	BP	
Fire Caulk	FCBALCOFIRESTOP	-	-	29
QT Wood Ties	QTB	-	-	31
	QTG	-	-	
	QTO	-	-	
	QTR	-	-	
QT Beam Connector	BPBC	-	-	35
QT Masonry Ties	QTBM	-	-	41
	QTGM	-	-	
	QTOM	-	-	
	QTRM	-	-	
QT Masonry Sleeve	QTMS	-	-	42

Foundation Connectors

QuickTie™ Accessories

QuickTie™ Cables

QT Products	QT	Reference Numbers		Page
		Simpson® Hardware (SH)	MiTek® Hardware (MH)	
Hurricane Anchors	HA4	H3, H3Z	RT3A, RT3A-TZ, RT4, RT4-TZ, RT5, RT5-TZ	43
	HA6	H2.5A, H2.5AZ, H2.5T	RT7A, RT7A-TZ, RT7AT	
	HA8	H8, H8Z	RT8A, RT8A-TZ	
	HA10	H10A, H10AZ, H14	RT16A, RT16A-TZ	
	HA10R	H10AR	RT16AR	
	HA10-2	H10A-2, H10A-2Z	RT16-2, RT16-2TZ	
Twist Straps	LTS12-3Z	LTS12	LTW12	44
	LTS16-3Z	LTS16	LTW16	
	LTS18-3Z	LTS18	LTW18	
	LTS20-3Z	LTS20	LTW20	
	MTS12-3Z	MTS12, MTS12Z	MTW12, MTW12-TZ	
	MTS16-3Z	MTS16, MTS16Z	MTW16, MTW16-TZ	
	MTS20-3Z	MTS20, MTS20Z	MTW20, MTW20-TZ	
	MTS24-3Z	-	-	
	HTS16-3Z	HTS16	HTW16	
	HTS20-3Z	HTS20, HTS20Z	HTW20, HTW20-TZ	
HTS24-3Z	HTS24	HTW24		
HTS28-3Z	-	HTW28		
Girder Connector	QGC	MGT, VGT	MUGT15	44
	QGCW	MGT, VGT	MUGT15	
Stud Plate Ties	RSPT4	RSP4	RSPT4	45
	RSPT6	SSP, SSPZ	RSPT6, RSPT6-TZ	
	RSPT6-2	DSP, DSPZ	RSPT6-2, RSPT6-2TZ	
	RSPT6M	SSP, SSPZ	RSPT6, RSPT6-TZ	
	SPT4-3Z	SP4	SPT4, SPT4-TZ	46
	SPT6-3Z	SP6	SPT6, SPT6-TZ	
	SPT8-3Z	SP8	SPT8, SPT8-TZ	
	SPH4-3Z	SPH4, SPH4Z	SPTH4, SPTH4-TZ	
SPH6-3Z	SPH6, SPH6Z	SPTH6, SPTH6-TZ		
SPH8-3Z	SPH8, SPH8Z	SPTH8, SPTH8-TZ		
Hurricane Gusset Angles	HGAKT	HGA10KT	HGA10KT	47
	HGAMKT	HGAM10KTA	HGAM10KT	
Deck Tension Tie	HDTT	DTT2Z, DTT2Z-SDS2.5	DTB-TZ	
Shear Clips/Flats	SC34	A34, A34Z	MP34, MP34-TZ	48
	SC35	A35, A35Z, L50, L50Z, L70, L70Z, L90, L90Z	MPA1, MPA1-TZ, AC5, AC5-TZ, AC7, AC7-TZ, AC9, AC9-TZ	
	SC35F	LTP4, LTP4Z, LTP5	MP4F, MP4F-TZ, MP6F	
Plywood Clips	PC38	PSCL3/8	RC38-250	48
	PC716	PSCL7/16, PSCA7/16	PC716	
	PC1532	PSCL15/32, PSCA15/32	PC1532	
	PC12	PSCL1/2, PSCA1/2	PC12	
	PC1932	PSCL19/32	PC1932	
	PC58	PSCL5/8, PSCA5/8	PC58	
Flat Straps	LS12	LSTA12	LSTA12	49
	LS18	LSTA18	LSTA18	
	LS24	LSTA24	LSTA24	
	MS24	MSTA24, MSTA24Z	MSTA24, MSTA24-TZ	
	MS36	MSTA36, MSTA36Z	MSTA36, MSTA36-TZ	
	MS48	MSTA48	MSTA49	

QT Products	QT	Reference Numbers		Page
		Simpson® Hardware (SH)	MiTek® Hardware (MH)	
Coil Strapping	CS20-250	CS20	RS250	50
	CS18-200	-	RS200	
	CS16-150	CS16	RS150	
	CS14-100	CS14	RS14-100	
	CMST16-54	CMSTC16	CMSTC16	
	CMST14-52.5, CMST14-12	CMST14	CMST14	
CMST12-40, CMSTC84	CMST12	CMST12		
Post Caps	PCM44	PC44	PCM44	54
	PCM46	PC46	PCM46	
	PCM48	PC48	PCM48	
	PCM64	PC64	PCM64	
	PCM66	PC66	PCM66	
	PCM68	PC68	PCM68	
	PCM77	-	PCM77	
	PCM84	PC84	PCM84	
	PCM86	PC86	PCM86	
	PCM88	PC88	PCM88	
	PCM44-16	PC44-16	PCM4416	
	PCM46-16	PC46-16	PCM4616	
	PCM48-16	PC48-16	PCM4816	
	PCM64-16	PC64-16	PCM6416	
	PCM66-16	PC66-16	PCM6616	
	PCM68-16	-	PCM6816	
PCM84-16	-	PCM8416		
PCM86-16	-	PCM8616		
PCM88-16	-	PCM8816		
End Post Caps	EPCM44	EPC44	EPCM44	54
	EPCM46	EPC46	EPCM46	
	EPCM48	EPC48	EPCM48	
	EPCM64	EPC64	EPCM64	
	EPCM66	EPC66	EPCM66	
	EPCM68	EPC68	EPCM68	
	EPCM77	-	EPCM77	
	EPCM84	EPC84	EPCM84	
	EPCM86	EPC86	EPCM86	
	EPCM88	EPC88	EPCM88	
	EPCM44-16	EPC44-16	EPCM4416	
	EPCM46-16	EPC46-16	EPCM4616	
	EPCM48-16	EPC48-16	EPCM4816	
	EPCM64-16	EPC64-16	EPCM6416	
	EPCM66-16	EPC66-16	EPCM6616	
	EPCM68-16	-	EPCM6816	
EPCM84-16	-	EPCM8416		
EPCM86-16	-	EPCM8616		
EPCM88-16	-	EPCM8816		

# QuickTie™ Product Index

QT Products	QT	Reference Numbers		Page
		Simpson® Hardware (SH)	MiTek® Hardware (MH)	

QT Products	QT	Reference Numbers		Page
		Simpson® Hardware (SH)	MiTek® Hardware (MH)	

Wood Connectors				
Column Caps	CCS325-4	CCQ3-4SDS2.5	KCCQ325-4	55
	CCS325-6	CCQ3-6SDS2.5	KCCQ325-6	
	CCS44	CCQ44SDS2.5	KCCQ44	
	CCS45	-	KCCQ45	
	CCS46	CCQ46SDS2.5	KCCQ46	
	CCS4-71	-	KCCQ47, KCCQ47X	
	CCS48	CCQ48SDS2.5	KCCQ48	
	CCS525-4	CCQ5-4SDS2.5	KCCQ525-4	
	CCS525-6	CCQ5-6SDS2.5	KCCQ525-6	
	CCS525-8	CCQ5-8SDS2.5	KCCQ525-8	
	CCS57	-	KCCQ57	
	CCS64	CCQ64SDS2.5	KCCQ64	
	CCS66	CCQ66SDS2.5	KCCQ66	
	CCS6-71	CCQ6-7.13SDS2.5	KCCQ67X	
	CCS68	CCQ69SDS2.5	KCCQ68	
	CCS74	CCQ74SDS2.5	KCCQ74	
	CCS76	CCQ76SDS2.5	KCCQ76	
	CCS77	CCQ76SDS2.5	KCCQ77	
	CCS78	CCQ78SDS2.5	KCCQ78	
	CCS71-4	CCQ7.1-4SDS2.5	KCCQ71-4	
	CCS71-6	CCQ7.1-6SDS2.5	KCCQ71-6	
	CCS71-71	CCQ7.1-7.1SDS2.5	KCCQ71-71	
	CCS71-8	CCQ7.1-8SDS2.5	KCCQ71-8	
	CCS84	CCQ84SDS2.5	KCCQ84	
	CCS86	CCQ86SDS2.5	KCCQ86	
	CCS88	CCQ88SDS2.6	KCCQ88	
	CCS94	-	KCCQ94	
	CCS96	CCQ96SDS2.5	KCCQ96	
CCS98	CCQ98SDS2.5	KCCQ98		
CCS106	CCQ106SDS2.5	KCCQ106		
End Column Caps	ECCS325-4	ECCQ3-4SDS2.5	KECCQ325-4	55
	ECCS325-6	ECCQ3-6SDS2.5	KECCQ325-6	
	ECCS44	ECCQ44SDS2.5	KECCQ44	
	ECCS45	-	KECCQ45	
	ECCS46	ECCQ46SDS2.5	KECCQ46	
	ECCS4-71	-	KECCQ47, KECCQ47X	
	ECCS48	ECCQ48SDS2.5	KECCQ48	
	ECCS525-4	ECCQ5-4SDS2.5	KECCQ525-4	
	ECCS525-6	ECCQ5-6SDS2.5	KECCQ525-6	
	ECCS525-8	ECCQ5-8SDS2.5	KECCQ525-8	
	ECCS5-71	-	KECCQ57	
	ECCS64	ECCQ64SDS2.5	KECCQ64	
	ECCS66	ECCQ66SDS2.5	KECCQ66	
	ECCS6-71	ECCQ6-7.13SDS2.5	KECCQ67X	
	ECCS68	ECCQ68SDS2.5	KECCQ68	
	ECCS74	ECCQ74SDS2.5	KECCQ74	
	ECCS76	ECCQ76SDS2.5	KECCQ76	
	ECCS77	ECCQ77SDS2.5	KECCQ77	
	ECCS78	ECCQ78SDS2.5	KECCQ78	

Wood Connectors					
Post Caps & End Post Caps	ECCS71-4	ECCQ7.1-4SDS2.5	KECCQ71-4	54	
	ECCS71-6	ECCQ7.1-6SDS2.5	KECCQ71-6		
	ECCS71-71	ECCQ7.1-7.1SDS2.5	KECCQ71-71		
	ECCS71-8	ECCQ7.1-8SDS2.9	KECCQ71-8		
	ECCS84	-	KECCQ84		
	ECCS86	ECCQ86SDS2.5	KECCQ86		
	ECCS88	ECCQ88SDS2.5	KECCQ88		
	ECCS94	-	KECCQ94		
	ECCS96	ECCQ96SDS2.5	KECCQ96		
	ECCS98	ECCQ98SDS2.5	KECCQ98		
	ECCS106	ECCQ106SDS2.5	KECCQ106		
	PCS44	AC4, AC4Z, LPC4Z	PBS44, PBS44-TZ, PB44-6TZ		54
	PCS44R	AC4R	PBS44R		
	PCS66	AC6, AC6Z, LPC6Z	PBS66, PBS66-TZ, PB66-6TZ		
	PCS66R	AC6R, AC6RZ	PBS66R, PBS66R-TZ		
PCES44	LCE4, LCE4Z	PBES44, PBES44-TZ	54		
PCES66	-	PBES66, PBES66-TZ			
Nail Protection Plates	NPP1	NS1	KNS1	56	
	NPP2	NS2	PL4		
	NPP58	PSPN58Z	ICPL58-TZ		
	NPP516	PSPN516Z	ICPL516-TZ		
Tension-Compression Straps	TCS18-3Z	CTS218	-	56	
	TCS20-3Z	-	-		
Top Flange Hangers	TFLP26	LB26, JB26	KLB26, HL26	57	
	TFLP28	LB28, JB28	KLB28, HL28		
	TFH210	JB210A	HL210		
	TFH212	JB212A	HL212		
	TFH214	JB214A	HL214		
Top Flange Heavy Hangers	TFHD26	HU26TF	HDO26	57	
	TFHD28	HU28TF	HDO28		
	TFHD210	HU210TF	HDO210		
	TFHD212	HU212TF	HDO212		
	TFHD26-2	HU26-2TF, HUS26-2TF	HDO26-2		
	TFHD28-2	HU28-2TF	HDO28-2		
	TFHD210-2	HU210-2TF, HUS210-2TF	HDO210-2		
	TFHD212-2	HU212-2TF, HUS212-2TF	HDO212-2		
	TFHD46	HU46TF	HDO46		
	TFHD410	HU410TF	HDO410		
	TFHD412	HU412TF	HDO412		
	TFHD414	HU414TF	HDO414		
	TFHD610	HU610TF	HDO610		
	TFHD612	HU612TF	HDO612		
	TFHD614	HU614TF	HDO614		
Top Flange Heavy Beam Hangers	TFHBH3512	HGLTV3.512	HLBH3512	58	
	TFHBH3514	HGLTV3.514	HLBH3514		
	TFHBH3516	HGLTV3.516	HLBH3516		
	TFHBH3518	HGLTV3.518	HLBH3518		
	TFHBH3520	HGLTV3.520	HLBH3520		
	TFHBH3595	HGLTV3.59	HLBH3595		
	TFHBH5514	HGLTV5.50H=14	14 / HLHB5514		
	TFHBH5516	HGLTV5.50H=16	16 / HLHB5516		
	TFHBH5518	HGLTV5.50H=18	18 / HLHB5518		
	Joist & Girder Hangers				

QT Products		QT	Reference Numbers		Page
			Simpson® Hardware (SH)	MiTek® Hardware (MH)	
Face Mount Girder Hangers		ULG	LGU	LGU	58
		UMG	MGU	MGU	
		UHG	HGU	HGU	
2x4	1-ply	ULP24	LU24, LUS24, U24	JL24, JUS24, SUH24	59
	2-ply	ULP24-2	LUS24-2, U24-2	JUS24-2, SUH24-2	
2x6	1-ply	UL26	LU26, LUS26	JL26, JUS26	59
	1-ply	ULP26	MUS26	MUS26	
	Rough	ULP26R	LU26R-18	-	
	1-ply	UM26	U26	SUH26	
	Rough	UM26R	U26R	SUH26R	
	1-ply	UH26	HU26	HD26	
(2) 2x6	2-ply	UL26-2	-	-	60
	2-ply	ULP26-2	LUS26-2, LUS26-2Z	JUS26-2, JUS26-2TZ	
	2-ply	UM26-2	U26-2	SUH26-2	
	2-ply	UH26-2	HUS26-2, HU26-2	HUS26-2, HD26-2	
(3) 2x6	3-ply	UL26-3	-	-	60
	3-ply	ULP26-3	LUS26-3	JUS26-3	
	3-ply	UM26-3	U26-3	SUH26-3	
	3-ply	UH26-3	HU26-3	HD26-3	
2x8	1-ply	UL28	LU28, LUS28, LUS28Z	JL28, JUS28, JUS28-TZ	60
	1-ply	ULP28	MUS28	MUS28	
	Rough	ULP28R	LU28R-18	-	
	1-ply	UM28	-	SUH28	
	Rough	UM28R	-	SUH28R	
	1-ply	UH28	HU28	HD28	
(2) 2x8	2-ply	UL28-2	-	-	60
	2-ply	ULP28-2	LUS28-2, LUS28-2Z	JUS28-2, JUS28-2TZ	
	2-ply	UM28-2	-	SUH28-2	
	2-ply	UH28-2	HUS28-2	HUS28-2	
(3) 2x8	3-ply	UL28-3	-	-	60
	3-ply	ULP28-3	LUS28-3, LUS28-3Z	JUS28-3, JUS28-3TZ	
	3-ply	UM28-3	-	-	
	3-ply	UH28-3	-	HD28-3	
2x10	1-ply	UL210	LU210, LUS210, U210	JL210, JUS210, SUH210, SUH210-TZ	61
	1-ply	ULP210	-	-	
	Rough	ULP210R	LU210R-18	-	
	Rough	UM210R	U210R	SUH210R	
	1-ply	UH210	HU210	HD210	
(2) 2x10	2-ply	UL210-2	-	-	61
	2-ply	ULP210-2	LUS210-2, LUS210-2Z	JUS210-2, JUS210-2TZ	
	2-ply	UM210-2	U210-2	SUH210-2	
	2-ply	UH210-2	HUS210-2	HUS210-2	
(3) 2x10	3-ply	UL210-3	-	-	61
	3-ply	ULP210-3	LUS210-3, LUS210-3Z	JUS210-3, JUS210-3TZ	
	3-ply	UM210-3	U210-3	SUH210-3	
	3-ply	UH210-3	HU210-3, HU210-3Z	HD210-3	
	3-ply (IF)	UH-IF210-3	HUC210-3, HUC210-3Z	HD210-3IF, HD210-3IFTZ	

QT Products		QT	Reference Numbers			Page
			Simpson® Hardware (SH)	MiTek® Hardware (MH)		
2x12	1-ply	UL212	-	-	61	
	1-ply	ULP212	-	-		
	1-ply	UM212	-	-		
	1-ply	UH212	HU212	HD212		
(2) 2x12	2-ply	UL212-2	-	-	61	
	2-ply	ULP212-2	-	-		
	2-ply	UM212-2	-	-		
	2-ply	UH212-2	HUS212-2	HUS212-2		
(3) 2x12	3-ply	UL212-3	-	-	61	
	3-ply	ULP212-3	-	-		
	3-ply	UM212-3	-	-		
	3-ply	UH212-3	HU212-3	HD212-3		
3x6	1-ply	ULP36	LUS36, LUS36Z	JUS36, JUS36-TZ	62	
	1-ply	UM36	U36	SUH36		
	1-ply	UH36	HU36	HD36		
3x8	1-ply	ULP38	-	JUS38	62	
	1-ply	UM38	-	-		
	1-ply	UH38	HU38	HD38		
3x10	1-ply	ULP310	LUS310	JUS310	62	
	1-ply	UM310	U310	SUH310		
	1-ply	UH310	HU310	HD310		
3x12	1-ply	ULP312	-	-	62	
	1-ply	UM312	-	-		
	1-ply	UH312	HU312	HD312		
4x6	1-ply	ULP46	LUS46, LUS46Z	JUS46, JUS46-TZ	62	
	1-ply	UM46	U46	SUH46		
	Rough	UM46R	U46R	SUH46R		
	1-ply	UH46	HUS46	HUS46		
4x8	1-ply	ULP48	LUS48, LUS48Z	JUS48, JUS48-TZ	62	
	1-ply	UM48	-	-		
	Rough	UM48R	-	-		
	1-ply	UH48	HUS48	HUS48		
4x10	1-ply	ULP410	LUS410, LUS410Z, U410	JUS410, JUS410-TZ, SUH410	62	
	1-ply	UM410	-	-		
	Rough	UM410R	U410R	SUH410R		
	1-ply	UH410	HUS410	HUS410		
4x12	1-ply	ULP412	-	-	62	
	1-ply	UM412	-	-		
	Rough	UM412R	-	-		
	1-ply	UH412	HUS412	HUS412		

# QuickTie™ Product Index

QT Products	QT	Reference Numbers		Page
		Simpson® Hardware (SH)	MiTek® Hardware (MH)	

QT Products	QT	Reference Numbers		Page
		Simpson® Hardware (SH)	MiTek® Hardware (MH)	

Face Mount Joist Hangers Cont.						
Joist & Girder Hangers	2x6	1-ply (IF)	ULP-IF26	LUC26Z	JL26IF-TZ	62
	(2) 2x6	2-ply (IF)	ULP-IF26-2	-	-	
	(3) 2x6	3-ply (IF)	ULP-IF26-3	-	-	
	2x8	1-ply (IF)	ULP-IF28	-	JL28IF-TZ	62
	(2) 2x8	2-ply (IF)	ULP-IF28-2	-	-	
	(3) 2x8	3-ply (IF)	ULP-IF28-3	-	-	
	2x10	1-ply (IF)	ULP-IF210	LUC210Z	JL210IF-TZ	62
	(2) 2x10	2-ply (IF)	ULP-IF210-2	-	-	
	(3) 2x10	3-ply (IF)	ULP-IF210-3	-	-	
	(2) 2x6	2-ply (IF)	UH-IF26-2	HUSC26-2	HUS26-2IF	62
	(3) 2x6	3-ply (IF)	UH-IF26-3	HUC26-3	HD26-3IF	
	3x6	1-ply (IF)	UH-IF36	HUC36	HD36IF	
	4x6	1-ply (IF)	UH-IF46	HUSC46	HUS46IF	62
	(2) 2X8	2-ply (IF)	UH-IF28-2	HUSC28-2, HUC28-2, HUC28-2Z	HUS28-2IF, HUS28-2IFTZ, HD28-2IF, HD28-2IFTZ	
	(3) 2X8	3-ply (IF)	UH-IF28-3	-	HD28-3IF	
	3x8	1-ply (IF)	UH-IF38	HUC38	HD38IF	62
	4x8	1-ply (IF)	UH-IF48	HUSC48	HUS48IF	
	(2) 2x10	2-ply (IF)	UH-IF210-2	HUSC210-2Z, HUC210-2, HUC210-2Z	HUS210-2IFTZ, HD210-2IF, HD210-2IFTZ	
	(3) 2x10	3-ply (IF)	UH-IF210-3	HUC210-3, HUC210-3Z	HD210-3IF, HD210-3IFTZ	62
	3x10	1-ply (IF)	UH-IF310	HUC310	HD310IF	
4x10	1-ply (IF)	UH-IF410	HUSC410	HUS410IF		
(2) 2x12	2-ply	UH-IF212-2	HUSC212-2, HUC212-2	HUS212-2IF, HD212-2IF	62	
(3) 2x12	3-ply	UH-IF212-3	HUC212-3	HD212-3IF		
3x12	1-ply (IF)	UH-IF312	HUC312	HD312IF		
4x12	1-ply (IF)	UH-IF412	HUSC412	HUS412IF	63	
Truss Hangers	Truss Strap Hangers (Top & Face Mount)	TSH29	THA29	MSH29		
		TSH213	THA213	MSH213		
		TSH218	THA218	MSH218		
		TSH218-2	THA218-2	MSH218-2		
		TSH222-2	THA222-2	MSH222-2		
		TSH413	THA413	MSH413		
		TSH418	THA418	MSH418		
		TSH422	THA422, THA422Z	MSH422, MSH422-TZ		
		TSH422-2	THA422-2	MSH422-2		
		TSH426	THA426	MSH426		
TSH426-2	THA426-2	MSH426-2				

Truss Hangers	Truss Hip Jack Hangers	THJH26	THJU26	HJC26	64
		THJH26	THJU26-W	HJC26SK60	
		UMSR/L24	SULR/L24	SKH24L/R	65
		UMSR/L26/28	SUR/L26	SKH26L/R	
		UMSR/L210/12	SUR/L210	SKH210L/R	
		UMSR/L214	SUR/L214	SKH210L/R	
		UMSR/L46/48	SUR/L46/48	SKH46L/R	
		UMSR/L410/412	SUR/L410/412	SKH410L/R	
		UMSR/L414	SUR/L414	SKH414L/R	
		UMSR/L310/312	SUR/L2.56/9	SKH2520L/R	
		UMSR/L314	SUR/L2.56/11	SKH2524L/R	
		UMSR/L26-2/28-2	SUR/L26-2	SKH26L/R-2	
		UMSR/L210-2/212-2	SUR/L210-2	SKH210L/R-2	
		UHSL/L46/48	HSUR/L46	SKHH46L/R	
		UHSL/L410/412	HSUR/L410	SKHH410L/R	
UHSL/L414	HSUR/L414	SKHH414L/R			
UHSL/L26-2/28-2	HSUR/L26-2	SKHH26L/R-2			
UHSL/L210-2/212-2	HSUR/L210-2	SKHH210L/R-2			
UHSL/L214-2	HSUR/L214-2	SKHH210L/R-2			
2x6	1-ply	UMH26	HUS26, HUS26Z	HUS26, HUS26-TZ	66
2x8	1-ply	UMH28	HUS28, HUS28Z	HUS28, HUS28-TZ	
2x10	1-ply	UMH210	HUS210, HUS210Z	HUS210, HUS210-TZ	
(2) 2x6	2-ply	UHH26-2	HHUS26-2, HHUS26-2Z	THD26-2	
(2) 2x8	2-ply	UHH28-2	HHUS28-2, HHUS28-2Z	THD28-2, THD28-2TZ	
(2) 2x10	2-ply	UHH210-2	HHUS210-2, HHUS210-2Z	THD210-2, THD210-2TZ	
(3) 2x10	3-ply	UHH210-3	HHUS210-3	THD210-3	
(4) 2x10	4-ply	UHH210-4	HHUS210-4	THD210-4	
4x6	1-ply	UHH46	HHUS46, HHUS46Z	THD46, THD46-TZ	
4x8	1-ply	UHH48	HHUS48, HHUS48Z	THD48, THD48-TZ	
4x10	1-ply	UHH410	HHUS410, HHUS410Z	THD410, THD410-TZ	
6x10	1-ply SCL	UHH610	HHUS5.50/10	THD610	
7x10	1-ply SCL/ Glulam	UHH7210	HHUS7.25/10	THD7210	

QT Products		QT	Reference Numbers		Page
			Simpson® Hardware (SH)	MiTek® Hardware (MH)	
4x6	1-ply	UHH46	HHUS46, HHUS46Z	THD46, THD46-TZ	66
4x8	1-ply	UHH48	HHUS48, HHUS48Z	THD48, THD48-TZ	
4x10	1-ply	UHH410	HHUS410, HHUS410Z	THD410, THD410-TZ	
6x10	1-ply SCL	UHH610	HHUS5.50/10	THD610	
7x10	1-ply SCL/Glulam	UHH7210	HHUS7.25/10	THD7210	
2x6	1-ply	UHD26	HGUS26	THDH26	
(2) 2x6	2-ply	UHD26-2	HGUS26-2	THDH26-2	
(3) 2x6	3-ply	UHD26-3	HGUS26-3	THDH26-3	
(4) 2x6	4-ply	UHD26-4	HGUS26-4	THDH26-4	
2x8	1-ply	UHD28	HGUS28	THDH28	
(2) 2x8	2-ply	UHD28-2	HGUS28-2	THDH28-2	
(3) 2x8	3-ply	UHD28-3	HGUS28-3	THDH28-3	
(4) 2x8	4-ply	UHD28-4	HGUS28-4	THDH28-4	
2x10	1-ply	UHD210	HGUS210	THDH210	
(2) 2x10	2-ply	UHD210-2	HGUS210-2	THDH210-2	
(3) 2x10	3-ply	UHD210-3	HGUS210-3	THDH210-3	
(4) 2x10	4-ply	UHD210-4	HGUS210-4	-	
(3) 2x12	3-ply	UHD212-3	HGUS212-3	THDH212-3	
(4) 2x12	4-ply	UHD212-4	HGUS212-4	-	
(3) 2x14	3-ply	UHD214-3	HGUS214-3	THDH214-3	
(4) 2x14	4-ply	UHD214-4	HGUS214-4	-	
3x10	1-ply Glulam	UHD3210	HGUS3.25/10	THDH3210	
3x12	1-ply Glulam	UHD3212	HGUS3.25/12	THDH3212	
4x6	1-ply	UHD46	HGUS46	THD46	
4x8	1-ply	UHD48	HGUS48	THDH48	
4x10	1-ply	UHD410	HGUS410	THDH410	
(2) 4x10	2-ply	UHD7310	HGUS7.37/10	-	
4x12	1-ply	UHD412	HGUS412	THDH412	
(2) 4x12	2-ply	UHD7312	HGUS7.37/12	-	
4x14	1-ply	UHD414	HGUS414	THDH414	
(2) 4x14	2-ply	UHD7314	HGUS7.37/14	-	
6x8	1-ply SCL	UHD558	HGUS5.50/8	-	
6x10	1-ply SCL	UHD5510	HGUS5.50/10	-	

QT Products		QT	Reference Numbers		Page
			Simpson® Hardware (SH)	MiTek® Hardware (MH)	
6x10G	1-ply Glulam	UHD5210	HGUS5.25/10	-	67
6x12	1-ply SCL	UHD5512	HGUS5.50/12	-	
6x12G	1-ply Glulam	UHD5212	HGUS5.25/12	THDH612	
6x14	1-ply SCL	UHD5514	HGUS5.50/14	THDH614	
7x10	1-ply Glulam	UHD6810	HGUS6.88/10	THDH6710	
7x12	1-ply Glulam	UHD6812	HGUS6.88/12	THDH6712	
7x14	1-ply Glulam	UHD6814	HGUS6.88/14	THDH6714	
8x10	1-ply SCL/Glulam	UHD7210	HGUS7.25/10	THDH7210	
8x12	1-ply SCL/Glulam	UHD7212	HGUS7.25/12	THDH7212	
8x14	1-ply SCL/Glulam	UHD7214	HGUS7.25/14	THDH7214	
Tension-Compression Connectors (Drag Strut Connectors)	TCC16R	DSC2R-SDS3	-	68	
	TCC16L	DSC2L-SDS3	-		
	TCC21R	DSC5R-SDS3	DSC4R		
	TCC21L	DSC5L-SDS3	DSC4L		
Truss Clips	TR1	STC	TR1	68	
	TR2	DTC	TR2		
	TR3	HTC4	HTC4		
Post-Install Girder Tie Downs	PHGT2	LGT2	LUGT2	69	
	PHHGT3	LGT3-SDS2.5	LUGT3		
	PHHGT4	LGT4-SDS3	LUGT4		
Sloped & Skewed Hangers	ULPSSH26	LSSJ26L/RZ, LSU26, LSU26Z, LSSU28, LSSU28Z	LSSH15-TZ	69	
	ULPSSH181	LSSR1.81Z	LSSH179, LSSH179-TZ		
	ULPSSH210	LSSU210, LSSU210Z	LSSH210, LSSH210-TZ		
Corner Hip Plates	CHP1.81	HCP1.81	-	70	
	CHP2	HCP2, HCP2Z	HHCP2, HHCP2-TZ		
	CHP4	HCP4Z	HHCP4-TZ		
Jack Truss Connectors	JTC37-3Z	TJC37	SNP3	70	
	JTC57-3Z	TJC57	-		
Screws	SWH	SDS	WS	71	
	SWH #9/#10	SD9/10	LL9		
	SWF	SDW	WSWH		
	SWT	SDWC	WSTS		
	SWL	SD	LL		

# Product Testing and Approvals

The products shown in this catalog have been fully engineered and tested. Most products have been evaluated and approved by the model code agencies and are listed in the published evaluation reports (e.g., ICC-ESR, Technical Evaluation Reports (TER) from DrJ Engineering, LLC and Florida Statewide Product Approvals).

These reports prove that the products used on a project meet the requirements of building codes listed below.

- 2015, 2018, 2021 and 2024 International Building Code (IBC)
- 2015, 2018, 2021 and 2024 International Residential Code (IRC)
- 2014, 2017, 2020 and 2023 Florida Building Code (FBC - Building & Residential)
- 2018 North Carolina Building Code (NCBC - Building & Residential)

TER and FL approvals are issued and updated throughout the year or when necessary. Visit [www.quicktie.com](http://www.quicktie.com), [www.drjengineering.org](http://www.drjengineering.org) & [www.floridabuilding.org](http://www.floridabuilding.org) to get the latest information.

## EVALUATION REPORTS (TER & ICC ESR) & FLORIDA APPROVALS (FL)

Evaluation Reports	FL Approvals	Products
TER 0910-01	FL #13468	QuickTie™ System (QTS)-Wood
		QTB(L) Blue 3/16" QuickTie™
		QTG(L) Green 1/4" QuickTie™
		QTO(L) Orange 5/16" QuickTie™
		QTR(L) Red 3/8" QuickTie™
	FL #3557	QuickTie™ Connectors
		CS20-250, CS18-200, CS16-150, and CS14-100 Coiled Straps
		CMST16-54, CMST14-52.5, and CMST12-40 Coiled Straps
		FASA4 Foundation Anchor Strap
		FSTHD8, FSTHD8J, FSTHD10, FSTHD10J, FSTHD14, and FSTHD14J Foundation Strap-Tie Hold Downs
		HA4, HA6, HA8, and HA10 Hurricane and Seismic Anchors
		HDTT45 and HDTT6 Hold Downs
		HD5, HD7, HD8, HD11, HD14, HD14, and HD22 Hold Downs
		HGA and HGAM Gusset Angles
		LTT20 Light Tension Tie
		METAS and HETAS Embedded Anchors
		MS and LS Straps
		LTS, MTS and HTS Twist Straps
		PAS18-3Z, PAS23-3Z, PAS28-3Z, PAS35-3Z, and PAS51-3Z Purlin Anchor Straps
		PBA44, PBA46, PBA66, PBA77, and PBA88 Post Base Anchors
		PBA44-4P/6P and PBA66-4P/6P Porch Post Base Anchors
		PCM and EPCM Post Caps
		PCS and PCES Post Cap Connectors
		PHGT2, PHHG3, and PHHG4 Girder Tie-Downs
		QGC and QGCW QuickTie™ Girder Connectors
		SC34, SC35 Framing Angles and SC35F Framing Plates
		SPArtan® Sill Plate Anchor
		TCC16L, TCC16R, TCC21L, and TCC21R Drag Strut Connectors
TCS18-3Z and TCS20-3Z Tension-Compression Straps		
TR1 and TR2 Roof Truss Clips		
RSPT4, RSPT6M, RSPT6 and RSPT6-2 Stud Plate Tie		
TER 1404-06	FL #17106	QuickTie™ System (QTS) Post-Tensioned Concrete Masonry Wall Applications
TER 1506-20	—	QTB(M) Blue 3/16" QuickTie™
		QTGM(L) Green 1/4" QuickTie™
		QTOM(L) Orange 5/16" QuickTie™
		QTRM(L) Red 3/8" QuickTie™
TER 1506-20	—	QuickTie™ System (QTS) Portal Frame with Hold-Downs (PFH)
TER 1811-03	FL #3557	QuickTie™ U-Hanger Series
		UL, ULP/ULP-IF, UM, UH/UH-IF, UHH & UHD Series Face Mount Hangers
		TFLP & TFH Series Top Flange Hangers
		UMSR/L & UHSR/L Series Skewed Hangers
		TSH Series Truss Strap Top and Face Mount Hangers
THJH Series Hip-Jack Truss Hangers, ULPSSH Series, Slopeable and Skewable Hangers		
ICC ESR-4467	—	QE-1 Adhesive Anchoring System For Cracked and Uncracked Concrete

## CODE APPROVALS



**TER 0910-01**  
(QuickTie™ Systems-Wood & QuickTie™ Connectors)



**TER 1811-03**  
(QuickTie™ U-Hanger Series)



**TER 1404-06**  
(QuickTie™ Systems-Masonry)



**TER 1506-20**  
(QuickTie™ Systems-Portal Frame)



**ESR-4467**  
(QE-1 Adhesive Anchoring System)

Allowable loads published in this catalog are determined by test criteria and calculations established by various industry standards (e.g., ASTM and AISI test procedures). For innovative products, QuickTie™ performs allowable load calculations based on rational engineering analysis along with extensive research and development efforts to confirm the product performance in the lab and the field.

QuickTie™ aims to provide solutions for complex problems, saving time and money for our valued customers, including contractors, installers, engineers, and others. Various patents assigned to QuickTie™ for wood and masonry structural applications are listed throughout this catalog.

**Corrosion:**

Corrosion is nature's way of breaking materials down over time. Metals like iron react with water and oxygen to form rust when exposed to harsh conditions.

Steel is an alloy made mainly of iron and carbon, with elements like chromium or nickel added to enhance its properties. It is widely used in construction, but it can corrode and deteriorate if not properly protected from harsh environmental conditions. In coastal areas, the presence of salt in the air significantly increases the risk of corrosion, as salt accelerates the reaction between moisture, oxygen, and steel, leading to rust and material degradation.

To address corrosion, we can either use materials that naturally resist it, like stainless steel, or protect the steel by applying coatings such as paint or galvanization. Galvanized or coated steel is often preferred due to the high cost of stainless steel.

The QuickTie structural connectors in this catalog feature a G185 [Triple-Zinc (3Z), superior to Hot-Dip Galvanization (HDG)] coating or an equivalent protective coating. Stainless Steel connectors available upon request. All SPArTan® anchors are coated with GEOMET® coating and Structural Wood Screws are coated with Dorken® coating.

**For Identification Purposes**

- Each individual QT part is marked with QT product name, QT logo and code compliance report #.
- The label on the shipping boxes includes the product identification details such as QT part number, QT logo, code compliance report #, quantity, installation instructions, etc



**General Notes for Allowable Load Tables**

1. Allowable loads are in pounds. SI Unit Conversions: 1" = 25.4 mm and 1 lbf = 4.5 N.
2. Unless noted otherwise, nails are common wire nails of the pennyweight noted in the tables. Nails shall comply with ASTM F1667 "Standard Specification for Driven Fasteners: Nails, Spikes, and Staples" and shall have the following minimum bending yield strengths, F<sub>yb</sub>.
  - 8d, D = 0.131 in., F<sub>yb</sub> = 100,000 psi
  - 10d, D = 0.148 in., F<sub>yb</sub> = 90,000 psi
  - 16d, D = 0.162 in., F<sub>yb</sub> = 90,000 psi
3. Nails designated as 8d x 1-1/2 are assumed to be 0.131" x 1.5" nails, nails designated as 8d or 8d common are assumed to be 0.131" x 2.5" nails, nails designated as 10d x 1-1/2 are assumed to be 0.148" x 1.5" nails, and nails designated as 10d or 10d common are assumed to be 0.148" x 3" nails. The number of fasteners shown is the minimum required to achieve the loads shown.
4. Tabulated allowable loads listed for a load duration factor of 1.00 (i.e. "Normal" load duration) are to be used in applications in which the shortest load duration in the combination of loads is 10-years. These values may be increased for applications in which the governing load duration factor is 1.15 or 1.25 in accordance with latest edition of the National Design Specification for Wood Construction (NDS®) up to the tabulated allowable loads for load duration factors of 1.33 and 1.60 or in accordance with the building code adopted by the jurisdiction in which the project is to be constructed.
5. The allowable loads included in this catalog are for QuickTie™ Connectors only. All framing members shall be designed in accordance with the building code adopted by the jurisdiction in which the project is to be constructed.
6. Load capacities in the design tables are valid for the species shown. For other species, adjust values in accordance with the latest NDS®.
7. Unless indicated otherwise, the allowable loads provided in this catalog assume the connector is attached to a wood member with a minimum nominal thickness of 2".
8. Allowable simultaneous loads in more than one direction on a single connector must be evaluated using the following equation:

$$\frac{\text{Design Uplift Load}}{\text{Allowable Uplift Load}} + \frac{\text{Design Load Parallel to Wall Plate}}{\text{Allowable Load Parallel to Wall Plate}} + \frac{\text{Design Load Perpendicular to Wall Plate}}{\text{Allowable Load Perpendicular to Wall Plate}} \leq 1.0$$

The building designer is responsible for determining the simultaneous loading conditions.

9. When cross-grain bending or cross-grain tension cannot be avoided in the members, mechanical reinforcement to resist such forces should be considered.

# Load Adjustment Factor for Alternate Fastener Types

For situations where a different nail size is used for the installation of the Face Mount Hangers, Post Base Anchors, Post Caps, Coiled Straps, Flat Straps, Twist Straps, Embedded Anchor Straps, Tension Ties, Shear Clips, Shear Flats, and Roof-Truss Clips, than what is stated in their respective tables in this catalog, adjustment factors are provided in table below.

Connector Table Fastener	Replacement Fastener	Load Adjustment Factor					
		Face Mount Hangers			Post Base Anchors, and Post Caps	Coiled/Flat/Twist Straps, Embedded Anchors Straps, and Tension Ties	Shear Clips/Flats, and Roof-Truss Clips
		Single Shear Connection	Double Shear Connection				
		Gravity/Uplift	Gravity	Uplift			
0.131 x 1-1/2	0.131 x 2-1/2	1.00	N/A	N/A	1	1	1
	0.148 x 1-1/4	1.00	N/A	N/A	1	1	1
	0.148 x 1-1/2	1.00	N/A	N/A	1	1	1
	0.148 x 2-1/2	1.00	N/A	N/A	1	1	1
	0.148 x 3-1/4	1.00	N/A	N/A	1	1	1
	0.162 x 2-1/2	1.00	N/A	N/A	1	1	1
	0.162 x 3-1/2	1.00	N/A	N/A	1	1	1
0.131 x 2-1/2	0.131 x 1-1/2	0.97	N/A	N/A	0.97	0.97	0.97
	0.148 x 1-1/4	1.00	N/A	N/A	1	1	1
	0.148 x 1-1/2	1.00	N/A	N/A	1	1	1
	0.148 x 2-1/2	1.00	1.00	1.00	1	1	1
	0.148 x 3-1/4	1.00	1.00	1.00	1	1	1
	0.162 x 2-1/2	1.00	1.00	1.00	1	1	1
	0.162 x 3-1/2	1.00	1.00	1.00	1	1	1
0.148 x 1-1/2	0.131 x 1-1/2	0.82	N/A	N/A	0.82	0.82	0.82
	0.131 x 2-1/2	0.85	N/A	N/A	0.85	0.85	0.85
	0.148 x 1-1/4	0.90	N/A	N/A	0.9	0.9	0.9
	0.148 x 2-1/2	1.00	N/A	N/A	1	1	1
	0.148 x 3-1/4	1.00	N/A	N/A	1	1	1
	0.162 x 2-1/2	1.00	N/A	N/A	1	1	1
	0.16 x 3-1/2	1.00	N/A	N/A	1	1	1
0.148 x 2-1/2	0.131 x 1-1/2	0.82	N/A	N/A	0.82	0.82	0.82
	0.131 x 2-1/2	0.85	0.87	0.87	0.85	0.85	0.85
	0.148 x 1-1/4	0.90	N/A	N/A	0.9	0.9	0.9
	0.148 x 1-1/2	1.00	N/A	N/A	1	1	1
	0.148 x 3-1/4	1.00	1.00	1.00	1	1	1
	0.162 x 2-1/2	1.00	1.00	1.00	1	1	1
	0.162 x 3-1/2	1.00	1.00	1.00	1	1	1
0.148 x 3-1/4	0.131 x 1-1/2	0.82	N/A	N/A	0.82	0.82	0.82
	0.131 x 2-1/2	0.85	0.70	0.70	0.85	0.85	0.85
	0.148 x 1-1/4	0.90	N/A	N/A	0.9	0.9	0.9
	0.148 x 1-1/2	1.00	N/A	N/A	1	1	1
	0.148 x 2-1/2	1.00	0.81	0.81	1	1	1
	0.162 x 2-1/2	1.00	0.92	0.92	1	1	1
	0.162 x 3-1/2	1.00	1.00	1.00	1	1	1
0.162 x 2-1/2	0.131 x 1-1/2	0.71	N/A	N/A	0.71	0.71	0.71
	0.131 x 2-1/2	0.73	0.76	0.76	0.73	0.73	0.73
	0.148 x 1-1/4	0.77	N/A	N/A	0.77	0.77	0.77
	0.148 x 1-1/2	0.86	N/A	N/A	0.86	0.86	0.86
	0.148 x 2-1/2	0.86	0.87	0.87	0.86	0.86	0.86
	0.148 x 3-1/4	0.86	0.99	1.00	0.86	0.86	0.86
	0.162 x 3-1/2	1.00	1.00	1.00	1	1	1
0.162 x 3-1/2	0.131 x 1-1/2	0.71	N/A	N/A	0.71	0.71	0.71
	0.131 x 2-1/2	0.73	0.58	0.58	0.73	0.73	0.73
	0.148 x 1-1/4	0.77	N/A	N/A	0.77	0.77	0.77
	0.148 x 1-1/2	0.86	N/A	N/A	0.86	0.86	0.86
	0.148 x 2-1/2	0.86	0.67	0.67	0.86	0.86	0.86
	0.148 x 3-1/4	0.86	0.83	0.83	0.86	0.86	0.86
	0.162 x 2-1/2	1.00	0.77	0.77	1	1	1

## NOTES:

1. Allowable load adjustment factors shown in the table are applicable to all products specified in this table, except as noted in the footnotes below.
2. Some products have been tested specifically with alternative fasteners and have allowable load adjustment factors or reduced capacities published in Report Number 0910-01, Report Number 1811-03, or [www.quicktieproducts.com](http://www.quicktieproducts.com). Values published therein may be used in lieu of using this table.
3. This table does not apply to skewed hangers or to hangers modified per allowed options, or to connectors made from steel thicker than 10-gauge.
4. Screws shall not be substituted for nails.
5. Nails and screws may not be combined in the same connection.
6. For straps installed over 5/8" maximum wood structural panel sheathing, use a 2-1/2"-long fastener minimum.
7. Nails that are 1-1/2" long fasteners may be substituted for the specified fastener into the header only; double-shear fasteners shall be minimum 2-1/2" long.

# SPArtan<sup>®</sup> SILL PLATE ANCHOR

(U.S. PATENT NO. 11,236,775)

The Most Efficient and  
Cost Effective Sill Plate  
Anchor on the Market!



## KEY ADVANTAGES OF SPArtan<sup>®</sup> ANCHORS:

- **Less Expensive** - Saves money and time on each job. Needs only one drill bit. Built in washer eliminates assembly.
- **Stronger** - Requires fewer anchors compared to traditional anchors. Less disturbance to the concrete.
- **Faster and Easier To Install** - No epoxy and no washer required. Easy and quick to screw in concrete. No need to change bits.
- **Geomet<sup>®</sup> Finish** - Coated with Geomet [superior to hot-dip galvanizing (HDG)] for permanent exterior and corrosive environments.



SPArtan<sup>®</sup> Installation Video

Quick Tie Products, Inc.  
quicktie.com

**MAIN OFFICE:**  
13300 Vantage Way  
Jacksonville, FL 32218  
Phone: (904) 281-0525  
info@quicktieproducts.com

# Concrete and Masonry Anchors

## SPArtan® SILL PLATE ANCHOR (U.S. PATENT NO. 11,236,775)

### PRODUCT FEATURES:

SPArtan® Sill Plate Anchors are post-installed anchors used to attach the sill plate of a wood framed wall to a concrete foundation/curb and rim boards to concrete/CMU walls. SPArtan® anchors are made from carbon steel wire and have a smooth shank shoulder (5/8" diameter x 1-1/2" long) at the top for sill plate and rim board attachments. This transitions into a threaded shank (3/8" diameter x 6" long) for concrete foundation/curb and concrete/CMU wall attachments. The head is comprised of a 1-1/4" diameter flange and a 3/8" square recess for easy anchor installation. SPArtan® anchors are designed to resist shear and tension loads due to wind and seismic forces in cracked and uncracked concrete.

### MATERIAL:

Hardened Carbon steel

### COATING:

GEOMET®, Superior to HDG

### INSTALLATION:

See below

### CODE COMPLIANCE:

TER 0910-01, FL 3557

Part No.	Carton Qty.
SPA67-100DB	100 SPArtan®, 1 SPArtan® Drill Bit
SPA67-100	100 SPArtan®
SPA67-50	50 SPArtan®
DBMSPA67	1 SPArtan® Drill Bit

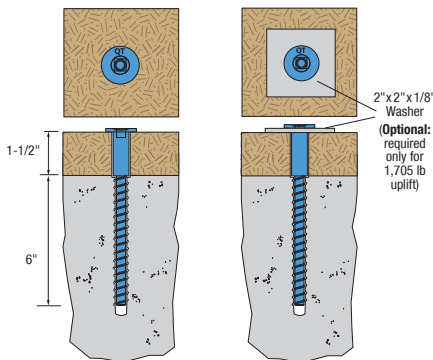

### SPArtan® ANCHOR ALLOWABLE SHEAR VALUES (ASD)

Applied Load	Allowable Loads (LB) <sup>1-6</sup>	
	Load Direction	Slab/Curb <sup>7</sup>
Shear	Parallel to Wood Grain (F <sub>1</sub> )	1,395
	Perpendicular to Wood Grain (F <sub>2</sub> )	665
Tension	Uplift (U)	1,155
	Uplift (U) with Washer <sup>8</sup>	1,705

### NOTES:

- Tabulated values are applicable to uncracked concrete and pressure treated Southern Pine #2 lumber.
- Allowable load values are determined using a conversion factor (ASD) of 1.6. The conversion factor is based on the controlling load case:  $(0.9D + W) / (0.6D + 0.6W)$ , where Dead Load (D) = 30% and Wind Load (W) = 70%. Adjustments shall be made where other load combinations control.
- Anchor design conforms to ACI 318 with no supplementary reinforcement considered.
- Anchor bending yield strength,  $F_{yb} = 100,000$  psi and concrete dowel bearing strength,  $F_e = 7,500$  psi.
- Allowable loads are provided for a 1.6 load duration ( $C_D$ ). No further increases are permitted.
- Allowable loads use a wet service factor  $C_M = 0.7$  (M.C. > 19%). No further reduction required.
- Minimum Requirements: Edge distance = 2.25 inches, End distance = 6 inches, Spacing = 6.75 inches, Embedment depth = 6 inches, Curb width = 6 inches, Slab/Curb depth = 9 inches and Concrete compressive strength = 2,500 psi.
- Washer size is 2 inch x 2 inch x 1/8 inch.

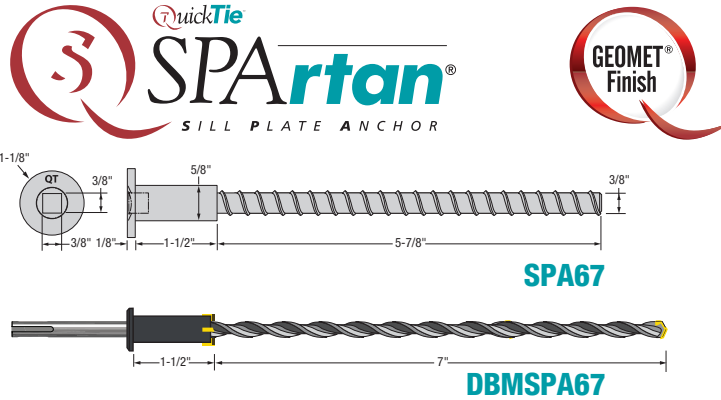

SPArtan™ Installation Video

**CAUTION:** Use of the SPArtan® Drill Bit is recommended. Oversizing of holes drilled in either the wood sill plate or concrete will reduce the load capacity of the anchor. The SPArtan® Drill bit is a proprietary, carbide-tipped step bit, custom designed for the installation of the SPArtan® anchors.

### SPArtan® ANCHOR SPACING EQUIVALENTS TO EPOXY ANCHOR

Epoxy Anchor Size	Epoxy Anchor Spacing					
	16"	24"	32"	36"	40"	48"
1/2"	30	45	61	68	76	91
5/8"	21	32	42	48	53	64

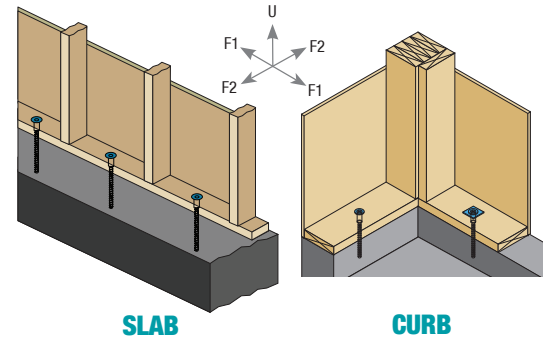

### NOTES:

- Tabulated values are based on the lateral resistance of sill plate (SP #2, PT) connection when loaded parallel to grain.
- Minimum requirements: Threaded rod length = 6"; Embedment depth = 3.5"; Edge distance = 2.25", End distance = 6"; Concrete compressive strength = 2,500 psi and Sill plate thickness = 1.5".
- Engineer-of-Record (EOR) to check anchor spacing limits for out-of-plane bending and deflection of sill plate.

### INSTALLATION INSTRUCTIONS

- Clean the top surface of sill plate and mark the SPArtan® anchor location(s).
- Use a rotary hammer drill and SPArtan® stepped drill bit (sold by Quick Tie Products, Inc.) to drill a hole in the sill plate. Stop and remove wood dust as necessary.
- Once the drill bit hits concrete, take precaution not to overwork the drill and/or drill bit. Intermittently, stop and clean concrete dust from the hole. If necessary, use compressed air (or other means) to remove debris around hole. Stop drilling when the wood bit stopper hits the top surface of sill plate. Over drilling may damage the carbide tips of wood bit.
- Install SPArtan® anchor using an impact drill with 3/8" square drive bit. Stop once the anchor flange hits the top surface of sill plate.

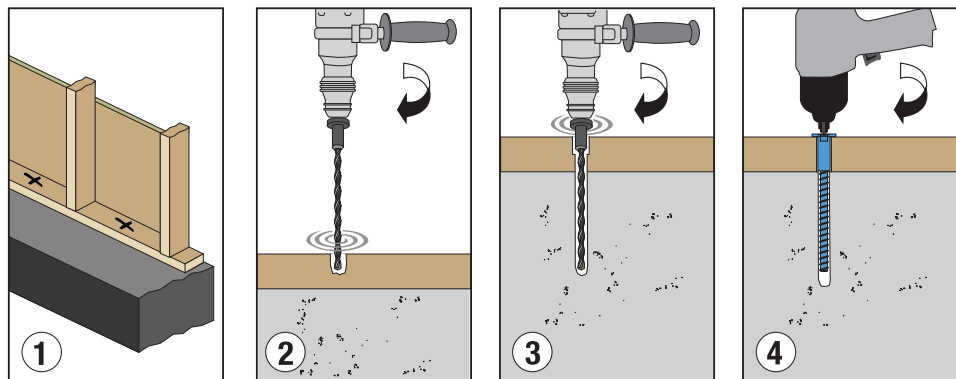

CAUTION: APPROPRIATE PERSONAL PROTECTIVE EQUIPMENT (PPE) MUST ALWAYS BE WORN

## ANCHOR CHAIR (AC33)

### PRODUCT FEATURES:

Anchor Chair (AC33) is utilized for the precise and easy placement of wet set/cast-in-place anchor rods in elevated slabs.

### MATERIAL:

AC33 - 16 ga

### COATING:

None

### INSTALLATION:

- Align nail holes over chalk line and nail to form.
- Install desired size anchor rod to AC33.

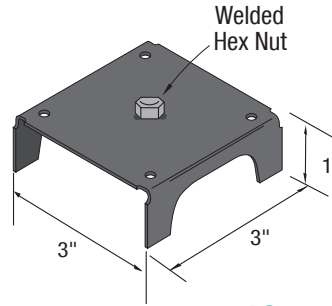

**AC33**

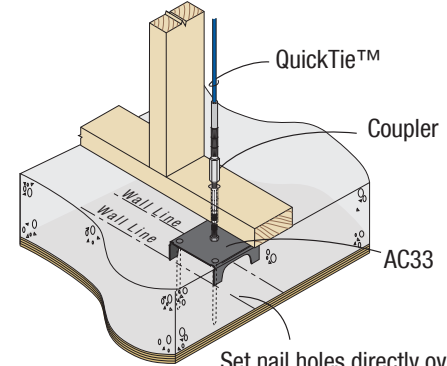
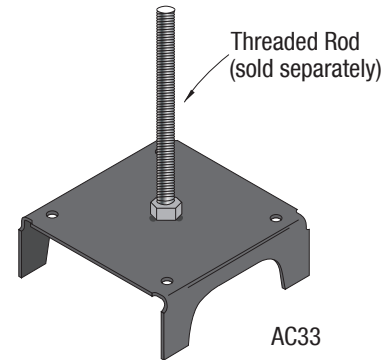

Set nail holes directly over chalk lines to align AC33 below wall, and place anchor in center of wall

Part No.	Description
AC33.37	Anchor Chair with 3/8" Welded Hex Nut
AC33.5	Anchor Chair with 1/2" Welded Hex Nut
AC33.62	Anchor Chair with 5/8" Welded Hex Nut
AC33.75	Anchor Chair with 3/4" Welded Hex Nut
AC33.87	Anchor Chair with 7/8" Welded Hex Nut
AC33.1.0	Anchor Chair with 1" Welded Hex Nut
AC33.1.12	Anchor Chair with 1-1/8" Welded Hex Nut
AC33.1.25	Anchor Chair with 1-1/4" Welded Hex Nut

## ANCHOR BOLT

### PRODUCT FEATURES:

Anchor bolts [ABG(L), ABO(L) & ABR(L)] are cast-in-place foundation anchors used to resist high wind uplift when assembled using QuickTie™ Couplers and QuickTie™ Cables (QTG, QTO & QTR).

Anchor bolts in bent forms [ABG(L)B, ABO(L)B & ABR(L)B] are available for the applications where edge distance cannot be met.

### ASSEMBLY:

Threaded Rod - ASTM A36 Steel, Zinc Plated

Hex Nut - Grade 2, Zinc Plated

Square Washer - ASTM A653 Grade 33 Steel, Galvanized (G90);  
ASTM A36 Steel, None or Zinc Plated

Coupler - Grade 2, Zinc Plated

### INSTALLATION:

- Concrete should be a minimum of 2,500 psi.
- Install anchor bolt at required edge distance and embedment depth.

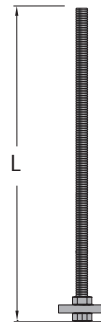

**ABG(L)  
ABO(L)  
ABR(L)**

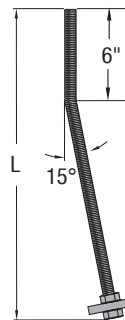
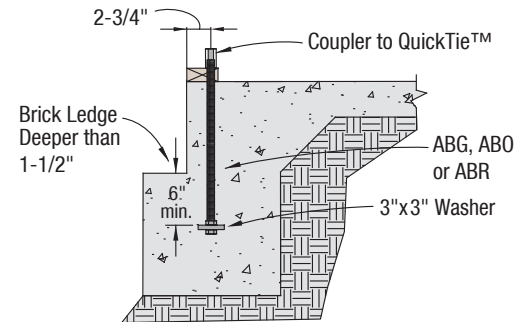

**ABG(L)B  
ABO(L)B  
ABR(L)B**

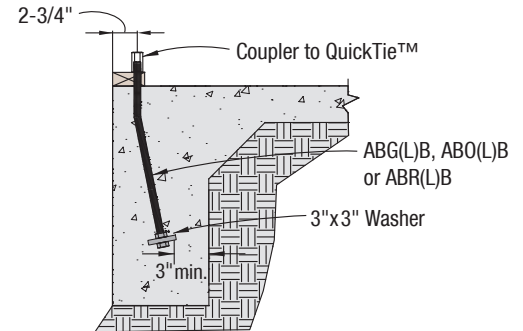

Use this detail when the min. edge distance cannot be accomplished

Part No.	Length (L)*	Description
ABG21Z	21"	1/2" Rod, 3" x 3" Washer, Hex Nuts & Coupler
ABG21BZ	21"	1/2" Rod (Bent), 3" x 3" Washer, Hex Nuts & Coupler
ABO21Z	21"	5/8" Rod, 3" x 3" Washer, Hex Nuts & Coupler
ABO21BZ	21"	5/8" Rod (Bent), 3" x 3" Washer, Hex Nuts & Coupler
ABO21BZ-NC	21"	5/8" Rod (Bent), HFL, 3" x 3" Washer, Hex Nuts & Coupler
ABR21Z	21"	3/4" Rod, 3" x 3" Washer, Hex Nuts & Coupler
ABR21BZ	21"	3/4" Rod (Bent), 3" x 3" Washer, Hex Nuts & Coupler
ABR24Z	24"	3/4" Rod, 3" x 3" Washer, Hex Nuts & Coupler
ABR24BZ	24"	3/4" Rod (Bent), 3" x 3" Washer, Hex Nuts & Coupler

# Concrete and Masonry Anchors

## ANCHOR BOLT ASSEMBLY (ABA)

### PRODUCT FEATURES:

Anchor Bolt Assembly (ABA) holds the anchor in place before pouring the concrete for both concrete slab/foundation and CMU wall applications (coupling application for QT cables).

### ASSEMBLY:

Hole Form Locator - 20 ga, Galvanized (G90)  
Threaded Rod - ASTM A36 Steel, Zinc Plated  
Hex Nut - Grade 2, Zinc Plated  
Couplers - Grade 2, Zinc Plated

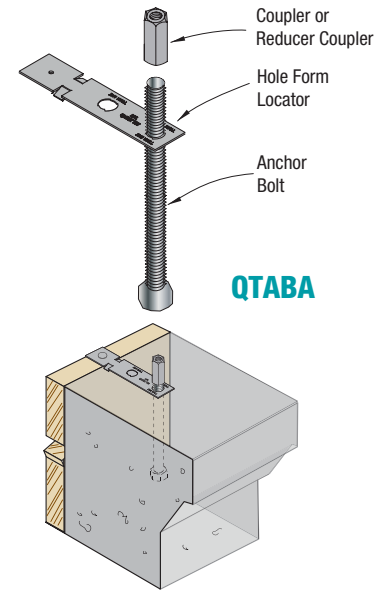
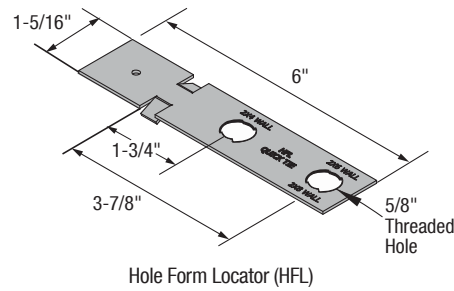

Part No.	Description
QTABA-Blue	Hole Form Locator, 5/8" Anchor Bolt & Reducer Coupler
QTABA-Green	Hole Form Locator, 5/8" Anchor Bolt & Reducer Coupler
QTABA-Orange	Hole Form Locator, 5/8" Anchor Bolt & Coupler
QTABA-Red	Hole Form Locator, 5/8" Anchor Bolt & Reducer Coupler

## CMU SADDLE ASSEMBLY

### PRODUCT FEATURES:

The CMU Saddle Assembly is designed to allow for easy installation and placement of Anchor Bolts when used with QuickTie™ Cables in concrete masonry wall applications. The CMU Saddle Assembly comes in eight different sizes to cover the four QuickTie™ sizes and 8" and 12" wide masonry walls. Each CMU Saddle Assembly includes saddle strap, anchor bolt and coupling.

### ASSEMBLY:

Saddle Strap - 20 ga, Galvanized (G90)  
Anchor Bolt - ASTM A36 Steel, Zinc Plated  
Couplers - Grade 2, Zinc Plated

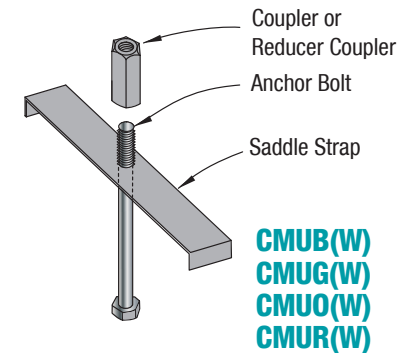
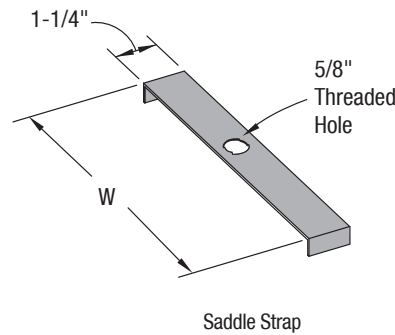

Part No.	Width (W)	Description
CMUB8	7-5/8"	8" CMU Wall, Saddle Strap, 5/8" Anchor Bolt & Reducer Coupler
CMUB12	11-5/8"	12" CMU Wall, Saddle Strap, 5/8" Anchor Bolt & Reducer Coupler
CMUG8	7-5/8"	8" CMU Wall, Saddle Strap, 5/8" Anchor Bolt & Reducer Coupler
CMUG12	11-5/8"	12" CMU Wall, Saddle Strap, 5/8" Anchor Bolt & Reducer Coupler
CMUO8	7-5/8"	8" CMU Wall, Saddle Strap, 5/8" Anchor Bolt & Coupler
CMUO12	11-5/8"	12" CMU Wall, Saddle Strap, 5/8" Anchor Bolt & Coupler
CMUR8	7-5/8"	8" CMU Wall, Saddle Strap, 5/8" Anchor Bolt & Reducer Coupler
CMUR12	11-5/8"	12" CMU Wall, Saddle Strap, 5/8" Anchor Bolt & Reducer Coupler

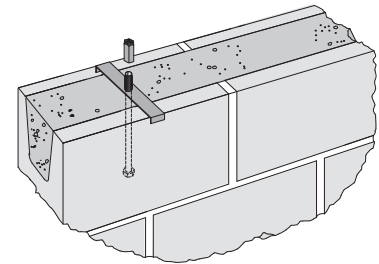

## EPOXY ANCHORS

### PRODUCT FEATURES:

Epoxy Anchors are used as foundation anchors to resist shear and wind uplifts.

### ASSEMBLY:

Threaded Rod - ASTM A36 Steel, Zinc Plated  
Hex Nut - Grade 2, Zinc Plated  
Square Washer - ASTM A653 Grade 33 or A36 steel, Galvanized (G60 or better), Zinc Plated or GEOMET® (Superior to HDG).

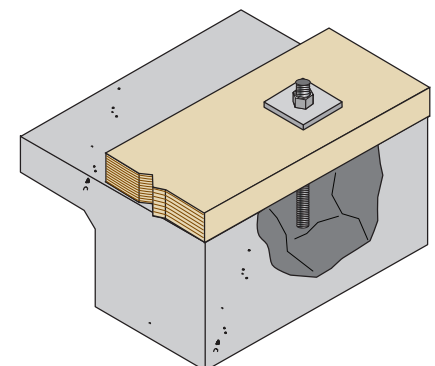
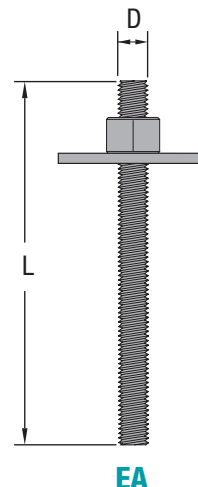

Part No.	Rod Size (D)	Length (L)*	Description
EA.5x6NS	1/2"	6"	1/2"x 6" Threaded Rod, Hex nut and 2 x 2 Galvanized (G185) washer
EA.5x6NS(3x3GEO)	1/2"	6"	1/2"x 6" Threaded Rod, Hex nut and 3 x 3 GEOMET® washer
EA.5x6NS(3x3Z)	1/2"	6"	1/2"x 6" Threaded Rod, Hex nut and 3 x 3 Zinc Plated (G60) washer
EA.5x8NS	1/2"	8"	1/2"x 8" Threaded Rod, Hex nut and 2 x 2 Galvanized (G185) washer
EA.625x6NS	5/8"	6"	5/8"x 6" Threaded Rod, Hex nut and 2 x 2 Galvanized (G185) washer
EA.625x8NS	5/8"	8"	5/8"x 8" Threaded Rod, Hex nut and 2 x 2 Galvanized (G185) washer

\*Other sizes and lengths available upon request

## FORM TIES (FT8 & FT6), FORM TIE - SHOT (FT6S) AND FORM TIE WEDGE (FTW) (U.S. PATENT NO. 9,834,945)

**PRODUCT FEATURES:**

Form Ties (FT8 & FT6), Form Tie-Shot (FT6S) and Form Wedge (FTW) anchors provide easy installation for the foundation contractor or framer. They can be used in either stem walls or slabs. They are easily attached to the form prior to placement of concrete.

**MATERIAL:**

FT8, FT6, FT6S - 16 ga

FTW - 12 ga

**COATING:**

Galvanized

**INSTALLATION:**

Scan QR code on top right.

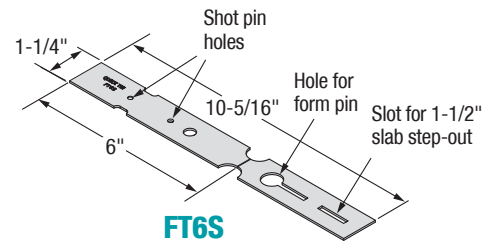
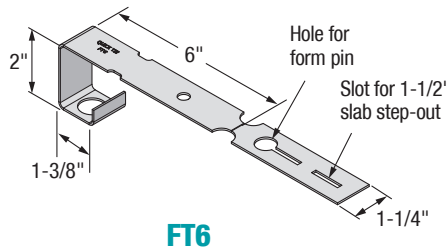
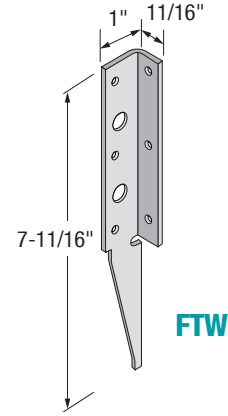
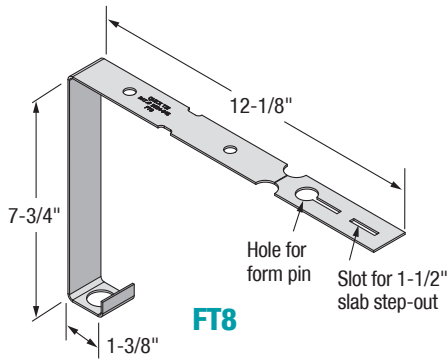

Form Tie Installation Video

Part No.	Carton Qty.
FT8	72
FT6, FT6S	100
FTW	100

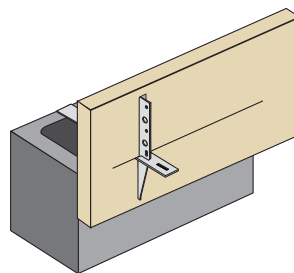
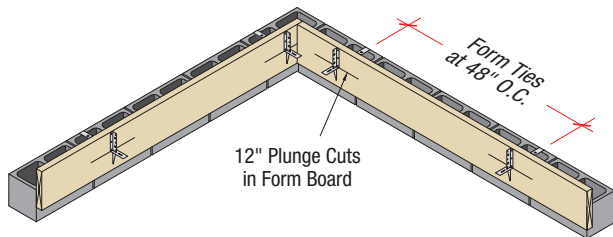
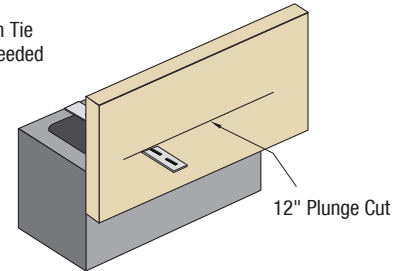
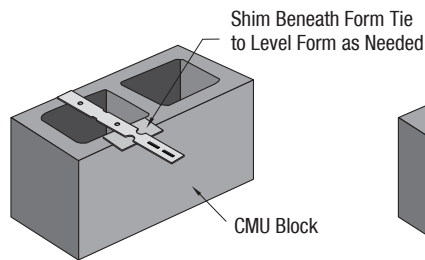
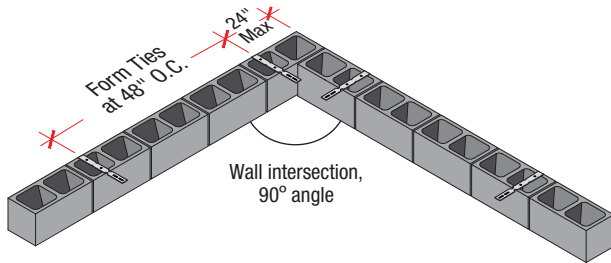

**Eliminates most, if not all, bracing**

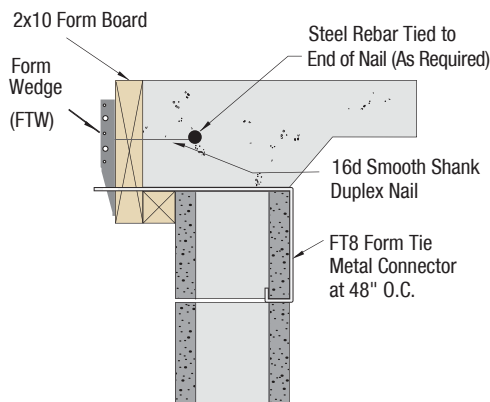
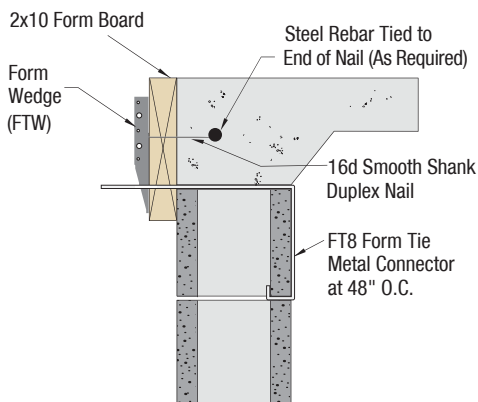

# Concrete and Masonry Anchors

## WALL TIES (WT)

### PRODUCT FEATURES:

QuickTie™ Wall Ties (WT6, WT8 & WT10) are designed to make concrete wall construction easier, faster, and more reliable. Made from high-strength Grade 80 steel, they help maintain consistent wall thickness, hold the formwork in place, and resist concrete pressure throughout the pouring and curing process.

### MATERIAL:

WT - 14 ga

### COATING:

None

### FAILURE LOAD:

7,200 lb.

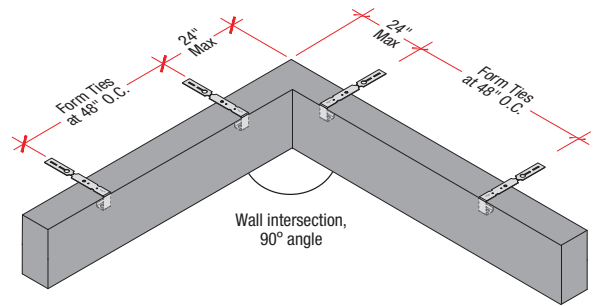
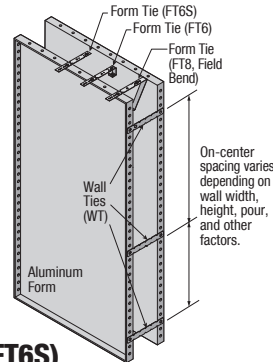
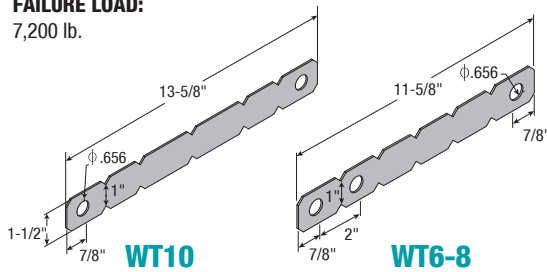
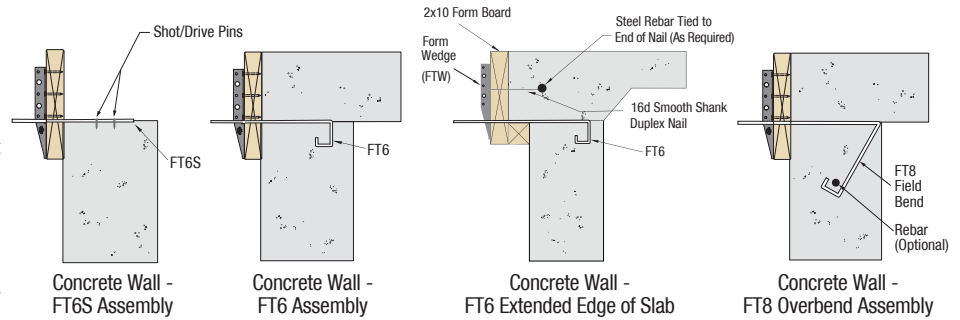

## CONCRETE WALL WITH FORM TIES (FT8, FT6 & FT6S)



Concrete slab formwork w/ Form Ties

Close-up view - Form Ties (FT8, FT6 or FT6S)

Slab concrete poured

Slab formwork removed

## FOUNDATION ANCHOR STRAP (FASA)

### PRODUCT FEATURES:

Foundation Anchor Strap (FASA4) is a cast-in-place connector designed for use as an alternative to anchor bolts. Each FASA4 strap has one end that is embedded into the concrete foundation. The other end extends above concrete foundation and is field bent over nominal 2x sill plates (with both legs bent around sill plate). Alternatively, one leg may be bent over the sill plate while the other leg is secured vertically over an adjacent stud.

### MATERIAL:

FASA4 - 16 ga

### COATING:

Galvanized (G185)

### INSTALLATION:

- Use all specified fasteners in schedule to achieve values indicated.

### CODE COMPLIANCE:

TER 0910-01, FL 3557

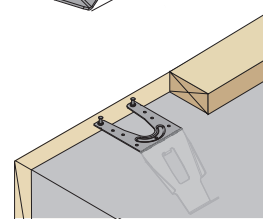
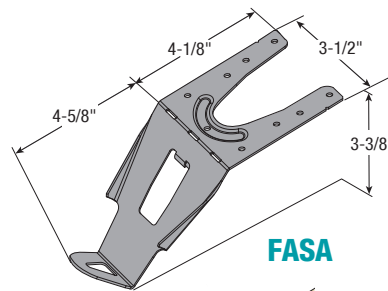

Option 1: Placement for inside wall attachment

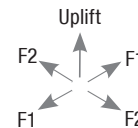
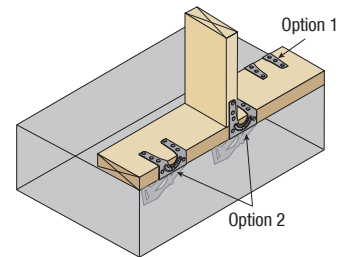

Field bend and attach

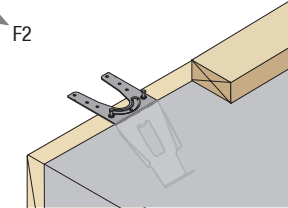

Option 2: Placement for outside wall attachment

## FASA4 ALLOWABLE TENSION AND SHEAR VALUES (ASD) - CONCRETE AND WOOD

Part No.	Installation Type <sup>9</sup>	Type	Fasteners			Allowable Loads (lb) <sup>1,3,4,5</sup>					
			Sill Plate <sup>2</sup>		Stud	Wind and Seismic Design Category (SDC) A-B			Seismic Design Category (SDC) C-F		
			Narrow Face	Wide Face		Uplift	F1 Parallel to Wall	F2 Perpendicular to Wall	Uplift	F1 Parallel to Wall	F2 Perpendicular to Wall
FASA4	Standard One Leg Up	10d x 1-1/2" (0.148 x 1.50")	3	6	-	1,310	1,620	1,250	1,150	1,360	1,190
			3	3	3	1,050	1,260	1,135	920	1,100	1,135

### NOTES:

- Allowable loads are provided for a load duration factor ( $C_D$ ) of 1.6. No further increase is permitted.
- Foundation plates or sills shall be pressure-preservative treated Southern Pine (PPT-SP) and shall comply with IBC Section 2304.3.1 and IRC Section R403.1.6.
- Allowable loads are only applicable to uncracked concrete and are based on a minimum stem wall thickness of 6", minimum distance from the end of the concrete stem wall to the center line of the FASA4 anchor of 4".
- Minimum compressive strength of concrete is 2,500 psi.
- Wood framing members (studs) with which the connectors are installed, "One Leg Up," shall have a published specific gravity (SG) of 0.55.

## FOUNDATION STRAP-TIE HOLDDOWNS (FSTHD)

### PRODUCT FEATURES:

The FSTHD and FSTHDJ series are embedded foundation strap-tie holddowns engineered to anchor wood framing (studs or posts) securely to concrete foundations or slabs. These holddowns are typically used at the ends of shear walls or in other high-stress framing locations where resisting uplift forces is critical.

### MATERIAL:

FSTHD8/8J – 14 ga  
FSTHD10/10J, 14/14J – 12 ga

### COATING:

Galvanized (G185)

### INSTALLATION:

- Use all specified fasteners in schedule to achieve values indicated.

### CODE COMPLIANCE:

TER 0910-01; FL 3557

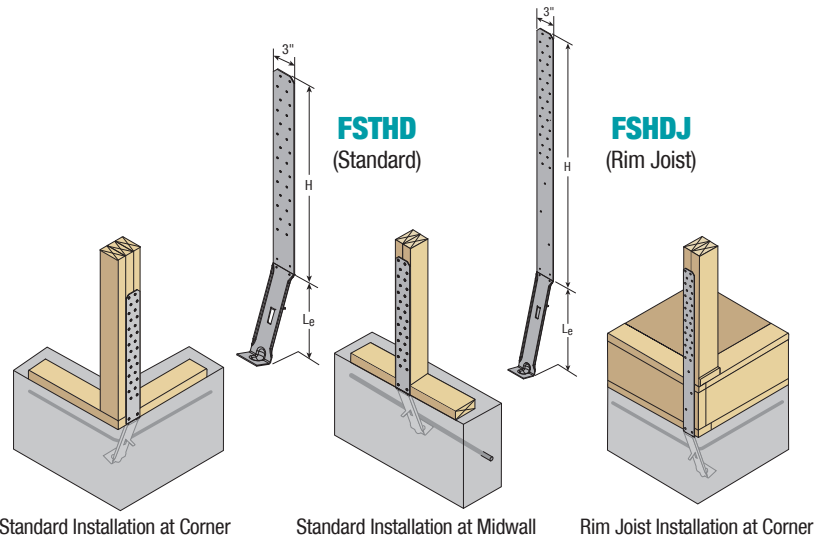

Standard Installation at Corner

Standard Installation at Midwall

Rim Joist Installation at Corner

## ALLOWABLE LOADS FOR FOUNDATION STRAP-TIE HOLDDOWNS (LB)<sup>1,2,3,4,5</sup>

Part No.	Embedment Length, $L_e$ (in.)	Strap Length, H (in.)	Stud Fasteners		SP		DF-L		HF/SPF	
			Type	Qty	Corner <sup>4</sup>	Mid-Wall <sup>5</sup>	Corner <sup>4</sup>	Mid-Wall <sup>5</sup>	Corner <sup>4</sup>	Mid-Wall <sup>5</sup>
FSTHD8	8	18-5/8	10d x 3-1/4" (0.148 x 3.25")	20	2,755	3,455	2,755	3,195	2,755	2,760
FSTHD8J		32-1/8								
FSTHD10	24-5/8									
FSTHD10J	38-1/8									
FSTHD14	26-1/8									
FSTHD14J	39-5/8									

### NOTES:

- Allowable loads are provided for a load duration factor ( $C_D$ ) of 1.6. No further increase is permitted. Total deflection of connector assembly at highest allowable load: FSTHD8 = 0.072", FSTHD10 = 0.068", FSTHD14 = 0.111"
- Minimum wood member size is 3" x 3-1/2".
- Minimum compressive strength of concrete is 2,500 psi. Minimum of one (1) #4 rebar is required at 6" embedment and 3" edge distance.
- For corner straps, minimum end distance is 1/2" and minimum center-to-center spacing is 3 times the embedment length.
- For mid-wall straps, end distance is 1.5 times the embedment length.

## PORCH POST BASE ANCHORS (PBA-P)

### PRODUCT FEATURES:

Porch Post Base Anchors (PBA-P) are used to attach the base of a wood post to a concrete foundation. These anchors are designed to withstand vertical construction loads prior to pouring of concrete and to support permanent porch framing throughout all stages of construction.

### MATERIAL:

PBA-P Strap & SO – 12 gs

### COATING:

Galvanized (G185)

### INSTALLATION:

- Use all specified fasteners in schedule to achieve allowable load values.
- The designer or specifier shall check the requirements and capacity of wood post and concrete for resisting gravity and uplift loads.
- Nails (10d common) and concrete screws are NOT included.
- Clean surface, place Post Base Porch Strap in position and install the screws per manufacturer's installation procedures.
- Insert the stand-off plate over the strap and position the wood post on top.
- Attach Post Base Porch Strap to wood post using 10d common nails on both sides

### CODE COMPLIANCE:

TER 0910-01; FL 3557

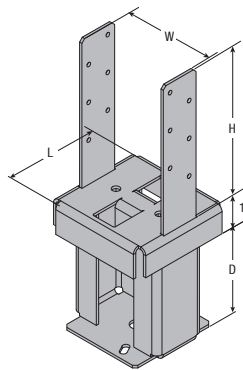

PBA44-4P/6P  
PBA66-4P/6P

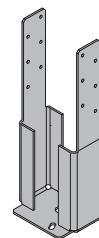

STRAP

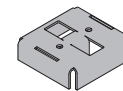

STAND-OFF (SO)

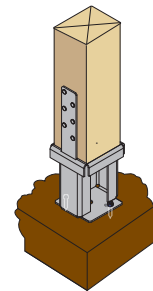

Prior to Concrete Pour

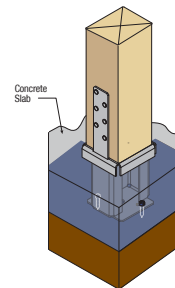

Embedded in Concrete

## ALLOWABLE LOADS FOR PORCH POST BASE ANCHORS, LB (PBA-P)<sup>1,2,3</sup>

Part No.	Strap Dimensions (in.)				Steel Thickness (Gauge)		Fasteners		SP (0.55) / DF-L (0.50)			
	Width	Length	Height	Depth					Post		Prior to Concrete Pour	
					W	L	H	D	Strap	Stand-Off	Qty	Size
PBA44-4P	3-5/8	3-5/8	5-7/8	4	12	12	12	10d	7,900	440	7,900	2,700
PBA44-6P				6								
PBA66-4P				4								
PBA66-6P	5-5/8	5-5/8	5-5/8	6	12	12	12	10d	12,775	440	12,775	2,700

### NOTES:

- Use two (2) 1/4" x 1-1/2" concrete screws to install prior to concrete pour. Minimum allowable pullout is 220 lb per screw with minimum edge and spacing of 2-1/2".
- Allowable load values provided are for wet service condition, no further reduction required.
- Minimum concrete compressive strength shall be 2,500 psi. Concrete design shall be performed by others.

# Post Base Anchors

## PBA SERIES

### PRODUCT FEATURES:

Post Base Anchors (PBA) are used to attach the base of a wood post to a concrete foundation. The PBAs are comprised of a Post Base Strap and a Stand-Off (SO) plate. The SO plate is designed to provide a 1-inch clearance between the bottom of the wood post and top of foundation in order to meet IBC Section 2304.12 and IRC Section R317 requirements for protection of wood-based products against decay.

### MATERIAL:

PBA Strap & SO - 12 ga

### COATING:

Galvanized (G185)

### INSTALLATION:

- Use all specified fasteners in schedule to achieve allowable load values.
- The designer or specifier shall check the requirements and capacity of wood post and concrete for resisting gravity and uplift loads.
- Nails (16d common) and anchor assembly (5/8" threaded rod, heavy hex nut, 2-3/4" x 2-3/4" x 3/8" washer and epoxy) are NOT included.
- Clean concrete surface, place Post Base Strap in position, mark the anchor bolt hole locations and drill holes using appropriate bit and drill.
- Replace Post Base Strap and install specified anchors with hex head or nut on top of the square washer.
- Place Stand Off Plate over hex nuts and position wood post on top.
- Attach Post Base Strap to wood post using 16d common nails on both sides.

### CODE COMPLIANCE:

TER 0910-01; FL 3557

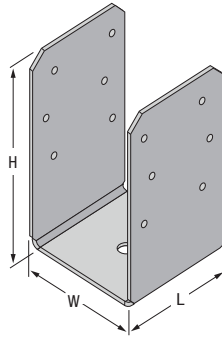

**POST BASE STRAP**

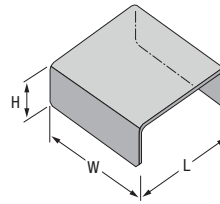

**STAND-OFF (SO) PLATE**

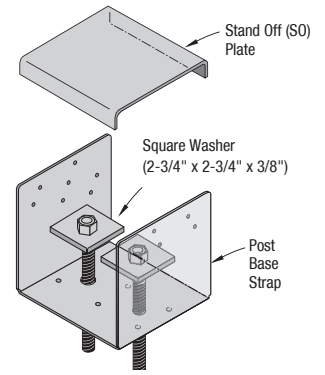

(PBA77/88 shown)

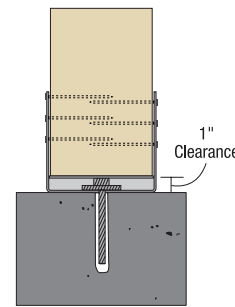
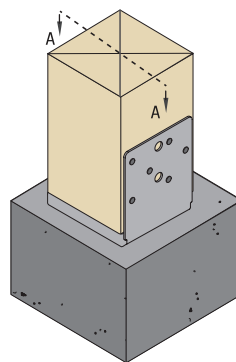

Section A-A

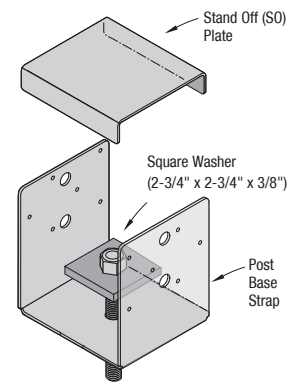

(PBA66 shown, PBA44/46 similar)

## ALLOWABLE LOADS FOR POST BASE ANCHORS (LB)<sup>1</sup>

Part No.		Strap Dimensions (in.)			Nominal Post Size	Fasteners				Southern Pine (0.55) or Douglas Fir-Larch (0.50)	
		Width	Length	Height		Post		Anchor		Bearing	Uplift
		W	L	H		Qty	Size	Qty	Size	C <sub>D</sub> = 1.0	C <sub>D</sub> = 1.6
PBA44	STRAP	3-9/16	3-1/2	5-1/2	4x4	12	16d	1	5/8	11,140	2,335
	SO	3-1/2	3-1/2	1							
PBA44R*	STRAP	4-1/16	3-1/2	5-1/4	4x4 (Rough)	12	16d	1	5/8	11,140	2,335
	SO	3-1/2	5	1							
PBA46	STRAP	3-9/16	5	6	4x6	12	16d	1	5/8	13,000	2,335
	SO	3-1/2	5	1							
PBA46R*	STRAP	4-1/16	5	5-3/4	4x4 (Rough)	12	16d	1	5/8	13,000	2,335
	SO	3-1/2	5	1							
PBA66 <sup>2</sup>	STRAP	5-1/2	5	6	6x6	12	16d	1	5/8	16,485	2,335
	SO	5-7/16	5	1							
PBA66R <sup>2*</sup>	STRAP	6	5	5-3/4	4x6 (Rough)	12	16d	1	5/8	16,485	2,335
	SO	5-7/16	5	1							
PBA77	STRAP	7-1/8	7-1/16	7-1/4	7x7	14	16d	2	5/8	16,485	3,590
	SO	7	7	1							
PBA88	STRAP	7-1/2	7-1/16	7-1/16	8x8	14	16d	2	5/8	27,065	3,590
	SO	7-3/8	7	1							
PBA88R*	STRAP	8-1/16	6-13/16	7	8x8 (Rough)	14	16d	2	5/8	27,065	3,590
	SO	7-15/16	6-13/16	1							
PBA1010*	STRAP	9	9-1/2	7-1/4	10x10	24	16d	2	5/8	35,310	3,590
	SO	9-1/2	8-3/4	1							
PBA1010R*	STRAP	9	10	7	10x10 (Rough)	24	16d	2	5/8	35,310	3,590
	SO	10	8-3/4	1							
PBA1212*	STRAP	11	11-1/2	7-1/4	12x12	24	16d	2	5/8	35,310	3,590
	SO	11-1/2	10-3/4	1							
PBA1212R*	STRAP	11	12-1/8	7-1/4	12x12 (Rough)	24	16d	2	5/8	35,310	3,590
	SO	12-1/16	10-3/4	1							

### NOTES:

1. Allowable load values provided are for wet service condition, no further reduction required.
  2. With 10-gauge strap, the allowable bearing and uplift loads are (C<sub>D</sub> = 1.6) are 16,485 lb and 2,545 lb, respectively.
  3. For higher bearing loads, pack grout solid under 1" standoff plate prior to installation. Base bearing loads on column or concrete, according to the building code.
- \*Call QT for code approval information.

## HD SERIES

### PRODUCT FEATURES:

Holdowns (HD) are used to resist uplift forces due to wind or overturning of shear walls. These are available in various sizes to meet the light to heavy load requirements using nails, screws and bolts as fasteners.

Other HD applications include purlin-to-purlin, Concrete/Masonry walls to decking or flooring attachments.

### MATERIAL:

See Allowable Loads Table.

### COATING:

Galvanized (G185) - LTT20, HDTT, HDTT3, HDTT6, HD5, HD7, HD8 & HD11

Spray Painted Primer (gray) - HD14 & HD22



### INSTALLATION:

- Use all specified fasteners in schedule to achieve values indicated

### CODE COMPLIANCE:

TER 0910-01; FL 3557

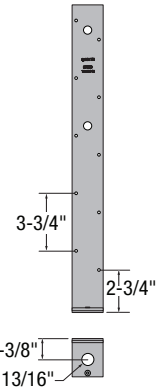
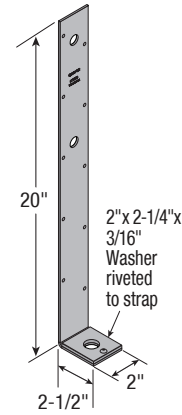

**LTT20**

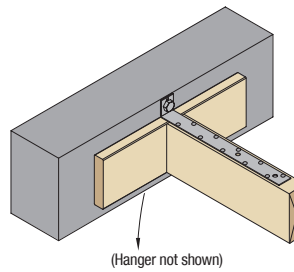

LTT20 as Tension Tie

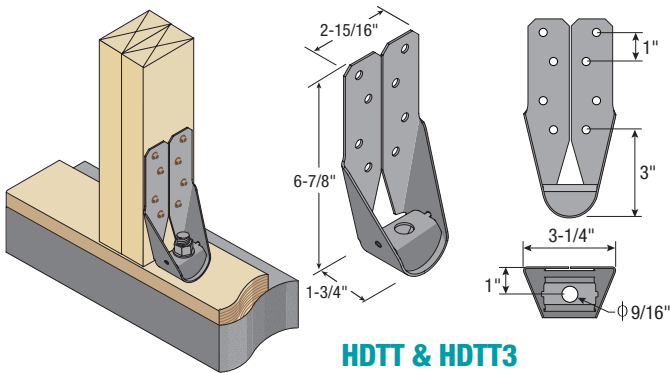
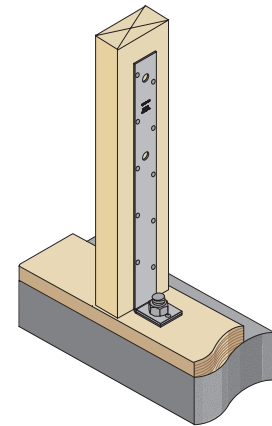

**HDTT & HDTT3**

(Part includes bend washer and structural wood screws)

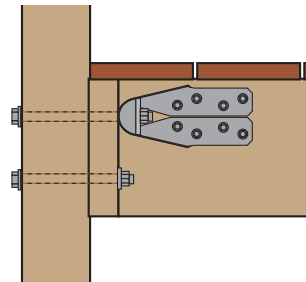

HDTT as Deck Tension Tie

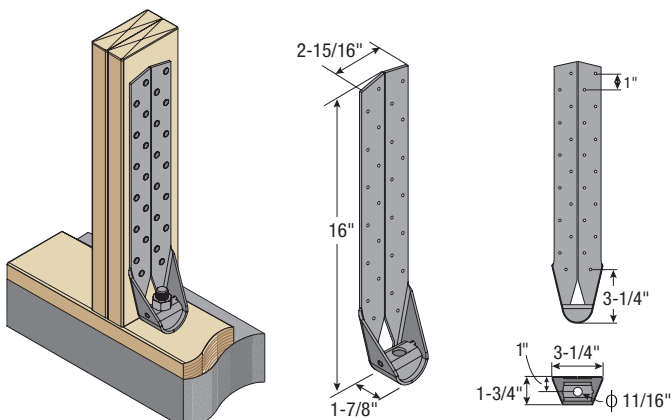
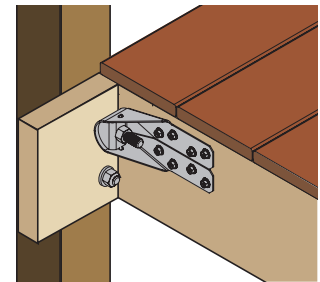

**HDTT6**

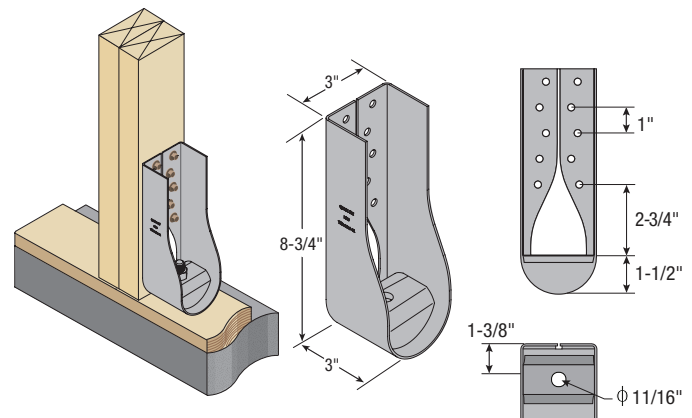

**HD5**

(Part includes bend washer and structural wood screws)

# Holdowns

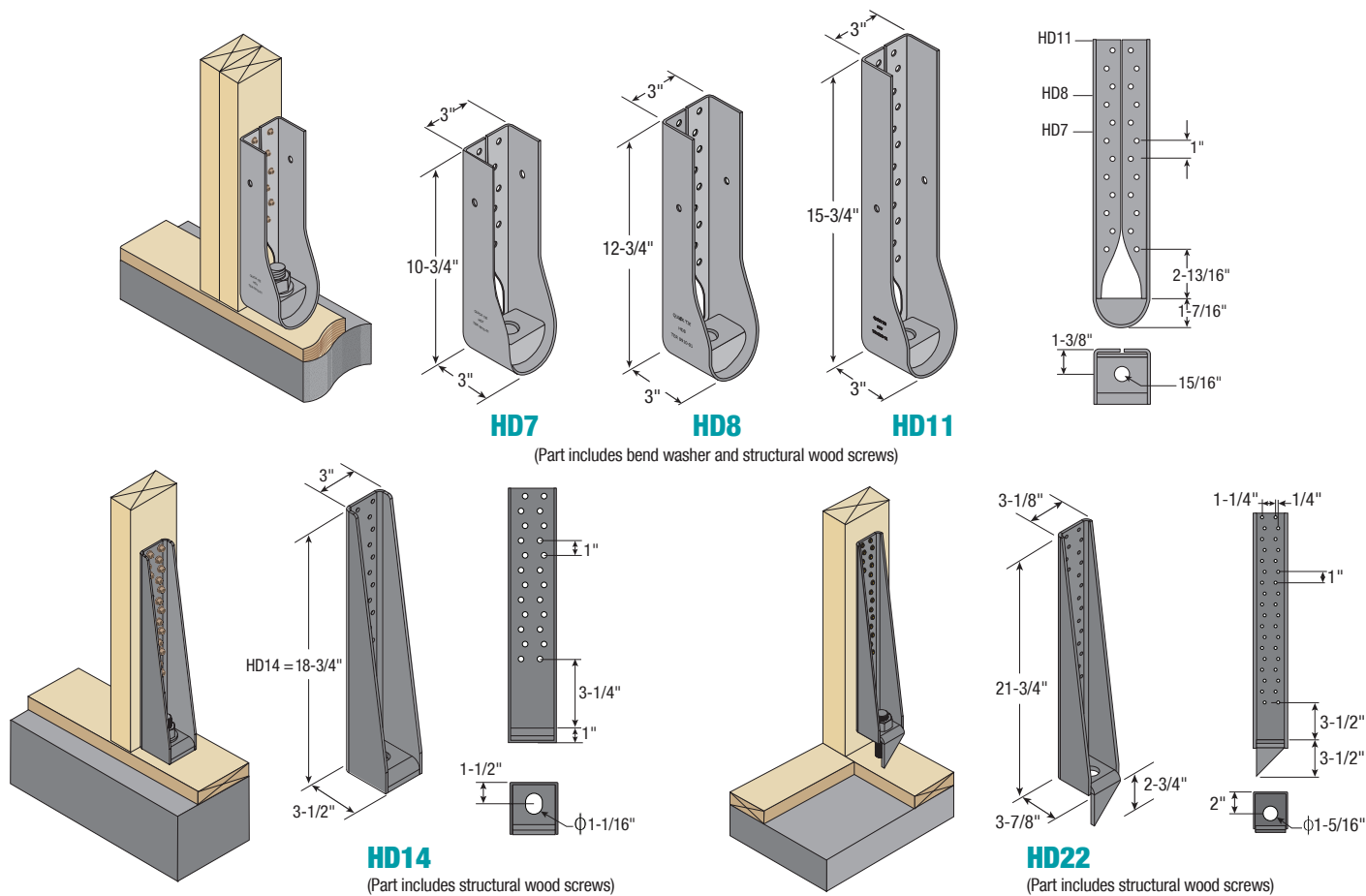

## ALLOWABLE LOADS FOR HOLDOWNS (LB)

QuickTie™	Part No. <sup>1,2</sup>		Steel Thick. <sup>3,4</sup> (ga)		Dimensions (in.)						Fasteners <sup>5,6</sup>				Allowable Load Values					
											Nails / Screws / Bolts		Anchor Bolt		SP (SG = 0.55)		DF-L (SG = 0.50)		S-P-F (SG = 0.42)	
	Reference No.	Strap	Washer	H	W	D	Stud Face to Anchor CL	Top of Bottom Plate to Top of Washer	Min. Wood Member Size <sup>2</sup> (in.)	Qty	Type / Size	Qty	Size	C <sub>D</sub> = 1.6		C <sub>D</sub> = 1.6		C <sub>D</sub> = 1.6		
	Simpson® Hardware (SH)	MiTek® Hardware (MH)												Uplift (lb)	Δ (in.)	Uplift (lb)	Δ (in.)	Uplift (lb)	Δ (in.)	
LTT20	LTT20B	LTS20B	12 ga	7 ga	20	2	2-1/2	1-3/8	9/32	(2) 2x4	10	10dx1-1/2	1	3/4"	1,680	0.194	1,575	0.186	1,375	0.172
HDTT	DTT2Z, DTT2Z-SDS2.5	DTB-TZ	14 ga	14 ga	6-7/8	3-1/4	1-3/4	1	1-1/8	2x4	8	SWH15	1	1/2"	2,300	0.190	2,055	0.149	1,525	0.088
HDTT3	HDU2-SDS2.5, HD3B	PHD2A, TDX2-TZ	12 ga	10 ga	6-7/8	3-1/4	1-3/4	1	1-3/16	(2) 2x4	8	SWH3	1	1/2"	3,475	0.074	3,210	0.067	2,770	0.055
HDTT6	HTT4, HTT5, HDUE3-SDS3	HTT45	10 ga	7 ga	16	3-1/4	1-7/8	1	1-1/4	(2) 2x4	26	16dx2-1/2	1	5/8"	5,480	0.145	5,480	0.145	4,895	0.129
HD5	HDU4-SDS2.5	PHD4A	14 ga	3 ga	8-3/4	3	3	1-3/8	1-1/2	(2) 2x4	10	SWH3	1	5/8"	5,885	0.197	5,445	0.181	3,365	0.106
HD7	HDU5-SDS2.5, HDUE5-SDS3	PHD5A	12 ga	3 ga	10-3/4	3	3	1-3/8	1-1/2	(2) 2x4	14	SWH3	1	7/8"	7,280	0.102	6,980	0.098	4,845	0.069
HD8	HDU8-SDS2.5, HDUE7-SDS3	PHD8	12 ga	3 ga	12-3/4	3	3	1-3/8	1-1/2	(2) 2x6	18	SWH3	1	7/8"	8,390	0.065	7,755	0.059	6,325	0.043
HD11	HDQ8-SDS3, HDU11-SDS2.5, HHQ11-SDS2.5, HDUE9-SDS3	UPHD8, UPHD9	12 ga	3 ga	15-3/4	3	3	1-3/8	1-1/2	(2) 2x4	24	SWH3	1	7/8"	11,855	0.118	11,080	0.112	8,305	0.088
										4x6	24	SWH3	1	7/8"	12,755	0.139	12,755	0.139	8,310	0.085
HD14	HHQ14-SDS2.5, HDUE13-SDS3	---	7 ga	3/8" Flat	18-3/4	3	3-1/2	1-1/2	1	4x6	30	SWH3	1	1"	14,120	0.095	14,060	0.095	11,170	0.075
HD22	HD19, HDU14-SDS2.5, HDUE17-SDS3	TD15, UPHD11, UPHD14	7 ga	3/8" Point	24-1/2	3-1/8	3-7/8	2	3-1/2	6x6	36	SWH3	1	1-1/4"	22,245	0.087	20,115	0.078	19,205	0.068

### NOTES:

- Anchor bolt installation into any substrates should be designed to resist the allowable uplift loads.
- Holdowns shall be installed into the wide face of the wood member in order to achieve the tabulated allowable load values.
- Refer to page 71 for structural wood screw SWH3 (1/4" x 3") and SWH15 (1/4" x 1-1/2") details.
- Bend washer (3/8" flat) welded to bend strap around perimeter with 1" offset from the base.
- Bend washer (3/8" point) welded to bend strap around perimeter with 3-1/2" offset from the base.
- These Reference Numbers above are for the purpose of enabling our customers to identify the QuickTie™ alternative to specified product names, but the attributes of the products references (particularly load values) may differ from the QuickTie™ part. Please note that product comparison via Reference Numbers is for general application comparison only. Reference Numbers should not be used as an apples-to-apples substitution tool. Customers are solely responsible for comparing specific load values, fastener schedules, anchoring requirements, material specifications, and other factors when determining the suitability of use of any particular product. QuickTie™ makes no claim, stated or implied, of suitability for purpose or qualification for usage of our products that may be substituted for a specified product. Any specification, submittal, or change to a specified product should be approved in writing by the designer or Engineer of Record (EOR). MiTek® and Simpson Strong-Tie® are registered trademarks of their respective companies, with which QuickTie™ is unaffiliated, and neither of whom endorse or approve use of their product names in this catalog as "reference numbers".

## PAS SERIES

### PRODUCT FEATURES:

QuickTie™ Purlin Anchor Straps (PAS) are used for joist to concrete or CMU wall attachment and foundation applications.

### MATERIAL:

PAS Series - 12 ga

### COATING:

Galvanized (G185)

### INSTALLATION:

- Use all specified fasteners in schedule to achieve the values indicated.
- PAS Series requires a minimum of 4" and 6" embedment into the concrete and CMU walls, respectively.
- Minimum concrete compressive strength is 2,500 psi.

### CODE COMPLIANCE:

TER 0910-01; FL 3557

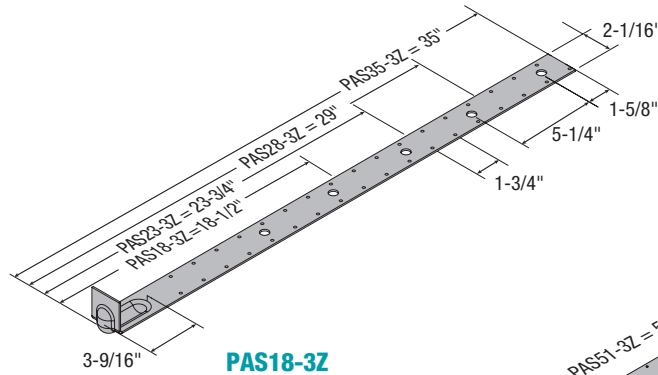

**PAS18-3Z**  
**PAS23-3Z**  
**PAS28-3Z**  
**PAS35-3Z**

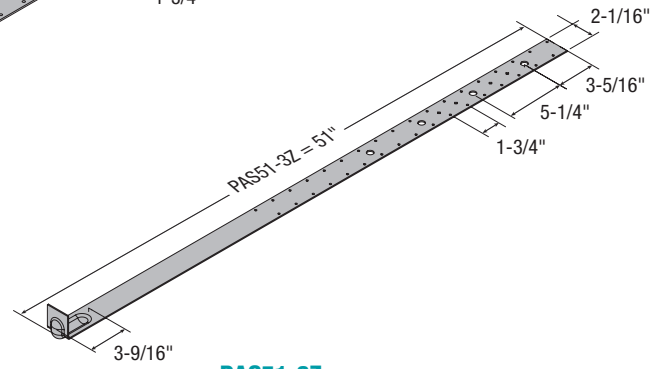

**PAS51-3Z**

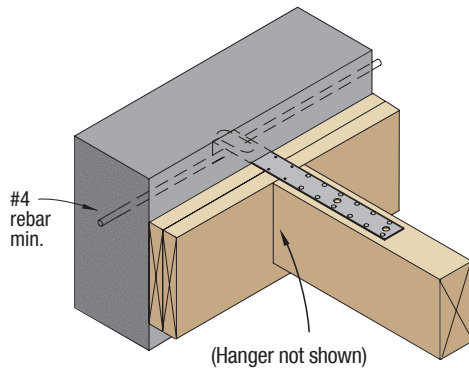

Purlin-to-Wall Attachment

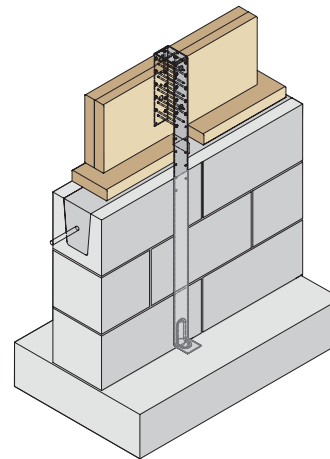

Rim Joist-to-CMU Stem Wall Attachment

## ALLOWABLE TENSION LOADS FOR PURLIN ANCHORS (LB)<sup>1</sup>

Part No.	Length, L (in.)	Embed Length, L <sub>e</sub> (in.)		Stud Fasteners		Allowable Loads (lb) <sup>1,4</sup>			
						SP / DF-L (SG = 0.50)		HF / SPF	
		Concrete <sup>2</sup>	CMU <sup>3</sup>	Type	Qty	Floor	Uplift	Floor	Roof
						1.0	1.6	1.0	1.6
PAS18-3Z	18-1/2	4	6	10d (0.148 x 3")	12	1,685	2,700	1,465	2,340
PAS23-3Z	23-3/4				16	2,250	3,600	1,950	3,120
PAS28-3Z	29				16	2,250	3,600	1,950	3,120
PAS35-3Z	35				16	2,250	3,600	1,950	3,120
PAS51-3Z	51				10	1,405	2,250	1,220	1,950

### NOTES:

1. Minimum wood member size is 3" x 3 1/2".
2. Minimum compressive strength of concrete is 3,000 psi.
3. Minimum compressive strength of grout-filled CMU is 2,000 psi.
4. Total deflection of connector assembly at highest allowable load is 0.031".

# Purlin Anchor Straps

## EMBEDDED TRUSS ANCHOR STRAPS (METAS/HETAS)

### PRODUCT FEATURES:

QuickTie™ Embedded Truss Anchor Straps (METAS/HETAS) are used for roof truss to concrete or CMU wall attachments.

### MATERIAL:

METAS Series - 18 ga  
HETAS Series - 16 ga

### COATING:

Galvanized (G185)

### INSTALLATION:

- Use all specified fasteners in schedule to achieve the values indicated.
- METAS/HETAS Series requires a minimum of 4" embedment into the concrete and CMU walls.

### CODE COMPLIANCE:

TER 0910-01; FL 3557

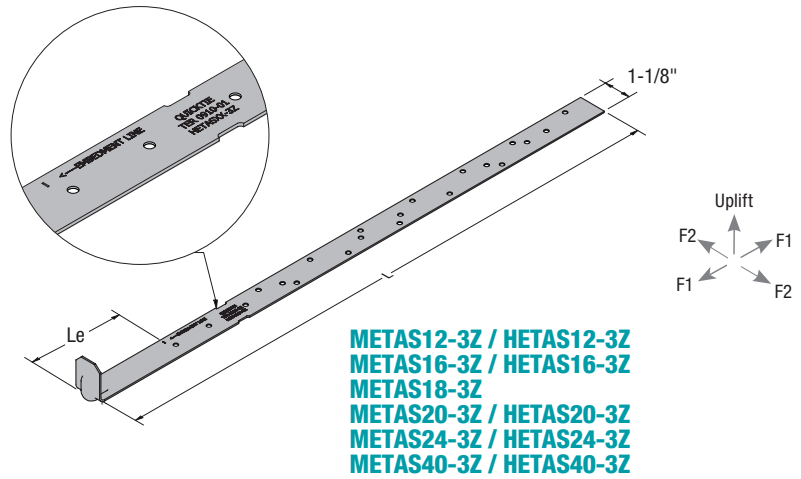

**METAS12-3Z / HETAS12-3Z**  
**METAS16-3Z / HETAS16-3Z**  
**METAS18-3Z**  
**METAS20-3Z / HETAS20-3Z**  
**METAS24-3Z / HETAS24-3Z**  
**METAS40-3Z / HETAS40-3Z**

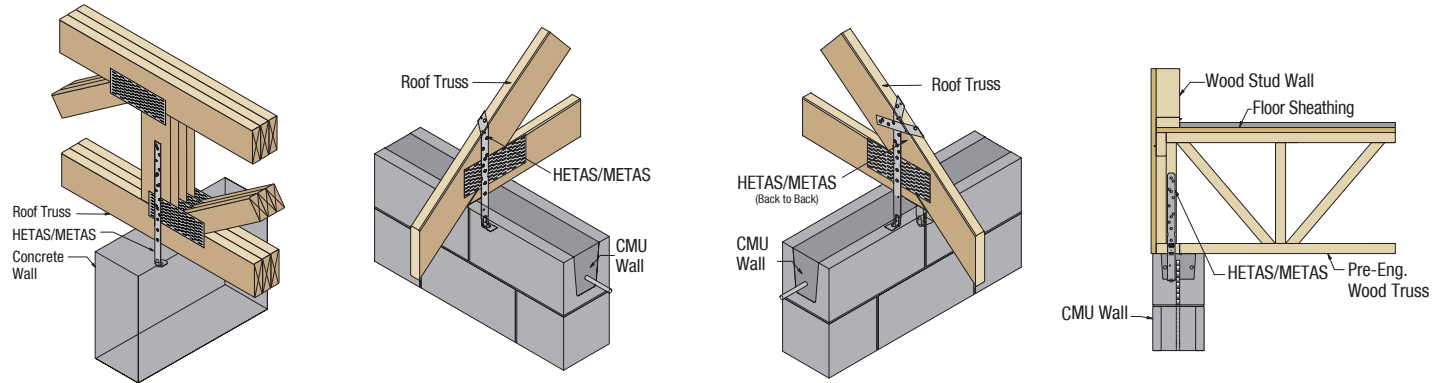

## ALLOWABLE LOADS FOR EMBEDDED TRUSS ANCHOR STRAPS (LB)<sup>1,2,3,4,5</sup>

Part No.	Length, L (in.)	Embed Length, L <sub>e</sub> (in.)		Fasteners		Allowable Loads (LB) - Southern Pine (SG = 0.55, C <sub>D</sub> = 1.6)																			
						Single Anchor						Double Anchor													
		Concrete	CMU	Qty	Nail Type	CMU			Concrete			CMU			Concrete										
						Uplift	F1	F2	Uplift	F1	F2	Uplift	F1	F2	Uplift	F1	F2								
METAS12-3Z	12	4	4	7	10dx1-1/2 (0.148 x 1.5")	1,445	340	760	1,445	340	760	2,890	1,335	1,140	2,890	1,335	1,140								
METAS16-3Z	16	4	4	9		1,600	440	760	1,600	440	760	3,195	1,375	1,140	3,195	1,375	1,140								
METAS18-3Z	18					4	4	9	10dx1-1/2 (0.148 x 1.5")	1,475	340	760	1,475	340	760	2,950	1,335	1,140	2,950	1,335	1,375				
METAS20-3Z	20									4	4	9	10dx1-1/2 (0.148 x 1.5")	1,895	440	760	1,895	440	760	3,325	1,375	1,140	3,175	1,405	1,375
METAS24-3Z	24													4	4	9	1,895	440	760	1,895	440	760	3,325	1,375	1,140
METAS40-3Z	40	4	4	9	1,895	440	760	1,895	440	760	3,325	1,375	1,140	3,175	1,405	1,375									

### NOTES:

1. Allowable loads are provided for load duration factor (C<sub>D</sub>) of 1.6. No further increase is permitted.
2. Minimum specified compressive strength of grout is 2,000 psi and minimum edge distance for CMU installation is 2 in.
3. Minimum specified compressive strength of concrete is 2,500 psi and minimum edge distance for concrete installation is 1.5".
4. Loading in F1 direction indicates shear forces parallel to the plane of the concrete/CMU wall.
5. Loading in F2 direction indicates shear forces perpendicular to the plane of the concrete/CMU wall.

## QUICKTIE™ EPOXY – QE-1

### PRODUCT FEATURES:

QuickTie™ QE-1 adhesives are an injectable two-component adhesive, tested to meet IBC requirements for both cracked and uncracked concrete applications. QE-1 adhesives are used for multiple anchoring systems, including QuickTie™ cables, fractional and metric threaded rod and rebar applications.

### CODE COMPLIANCE:

ICC-ESR 4467

Part No.	Description	Standard Box Package
QE-1*	Quick Set Anchoring Epoxy - 19.8 oz	6
QE-1TL**	High Performance Manual Tool (19.8 oz)	1
1BSH	Epoxy Hole Cleanout Brush	1

\* One mixing nozzle is packaged with each cartridge. QE-1 & QE-2 mixing nozzles must be used to ensure complete and proper mixing of the adhesive.

\*\* For pneumatic or cordless, battery operated dispensing tools, contact QuickTie™ for ordering information.



**ESR-4467**  
(QE-1 Adhesive  
Anchoring System)



**QE-1 (19.8 OZ.)**



**QE-1TL (19.8 OZ.)**



**1BSH**



**QE-1 NOZZLE**

## QE-1 STRENGTH DESIGN AND ALLOWABLE STRESS DESIGN TENSION VALUES FOR THREADED RODS<sup>1-8</sup>

Rod Diameter, D (in.)	Slab Thickness, h <sub>a</sub> (in.)	Embed Depth, h <sub>ef</sub> (in.)	End Distance, c <sub>a2</sub> (in.)	Critical Edge Distance, c <sub>ac</sub> (in.)	Concrete	ALLOWABLE TENSION (LB) - 2,500 PSI CONCRETE												
						At Edge Distance, c <sub>a1</sub>												
						1-3/4"	2"	2-1/4"	2-1/2"	2-3/4"	3"	3-1/4"	3-1/2"	3-3/4"	4"	5"	6"	c <sub>ac</sub>
3/8	12	4	7	7-1/8	Cracked (SD)	1,640	1,720	1,805	1,895	1,980	2,070	2,160	2,255	2,350	2,450	2,855	3,185	3,185
					Uncracked (SD)	2,675	2,805	2,935	3,075	3,210	3,350	3,495	3,645	3,790	3,945	4,580	5,260	6,240
					Uncracked (ASD)	1,650	1,730	1,810	1,895	1,980	2,065	2,155	2,250	2,335	2,435	2,825	3,245	3,850
1/2	12	4	7	6-3/8	Cracked (SD)	-	-	2,125	2,210	2,295	2,380	2,470	2,555	2,645	2,740	3,120	3,520	3,665
					Uncracked (SD)	-	-	3,295	3,450	3,605	3,760	3,925	4,085	4,255	4,425	5,140	5,900	6,240
					Uncracked (ASD)	-	-	2,030	2,125	2,225	2,320	2,420	2,520	2,625	2,730	3,170	3,640	3,850
5/8	18	6-5/8	7	10-5/8	Cracked (SD)	-	-	-	3,895	4,010	4,130	4,250	4,370	4,495	4,620	5,130	5,670	8,305
					Uncracked (SD)	-	-	-	5,140	5,295	5,450	5,610	5,770	5,935	6,100	6,775	7,485	11,725
					Uncracked (ASD)	-	-	-	3,170	3,265	3,360	3,460	3,560	3,660	3,765	4,180	4,620	7,235
3/4	24	8-1/8	7	12-5/8	Cracked (SD)	-	-	-	-	-	4,855	4,975	5,095	5,215	5,340	5,845	6,370	10,250
					Uncracked (SD)	-	-	-	-	-	6,620	6,780	6,945	7,110	7,280	7,965	8,685	14,470
					Uncracked (ASD)	-	-	-	-	-	4,085	4,185	4,285	4,385	4,490	4,915	5,360	8,930

### NOTES:

- QE-1 has an installation temperature range of 5° F to 104° F for structural applications.
- All Strength Design (SD) values listed are controlled by bond strength.
- Table represents performance at specific edge distance, hole diameter and embedment depth conditions.
- Table values reflect reduction for use in a Condition B application, where supplementary reinforcement is not present.
- Allowable tension loads calculated based on strength design provisions of IBC Section 1605.2 with the following assumptions:
  - Temperature range A: Maximum short term temperature = 176° F (80° C), Maximum long term temperature = 122° F (50° C)
  - f<sub>c</sub> = 2,500 psi, normal-weight concrete.
  - Single anchor, vertically down with periodic special inspection and no seismic loading.
  - φ<sub>t</sub> = 0.65 for dry concrete, with ASTM A193, Grade B7 threaded rod.
- For short term temperature exposure greater than 176° F (80° C) and up to 248° F (120° C), apply a reduction factor of 0.90 to the allowable tension load.
- For short term temperature exposure greater than 248° F (120° C) and up to 302° F (150° C), apply a reduction factor of 0.80 to the allowable tension load.
- Allowable Stress Design (ASD) loads based on ACI load combination - 0.9D + W / 0.6D + 0.6W, assuming dead load of 30% and wind load of 70% giving a weighted average (c) of 1.62.

## THREADED RODS (TR)

### PRODUCT FEATURES:

Threaded Rods are used for Epoxy Anchor assembly and as extension rod to connect QuickTie™ Cables to top plate with couplers.

### MATERIAL:

ASTM A36, F1554 (Grade 36, Class 2A) or A307 (Grade A) steel, F1554 (Grade 105) or A193 (Grade B7)

### COATING:

Plain (uncoated), Zinc Plated (Z) and HDG

Part No.	Rod Size (D)*	Length (L)*
TR.375x6	3/8"	6"
TR.375x8		8"
TR.375x10		10"
TR.375x12		12"
TR.375x24		24"
TR.5x6	1/2"	6"
TR.5x8		8"
TR.5x10		10"
TR.5x12		12"
TR.5x24	24"	
TR.625x6	5/8"	6"
TR.625x8		8"
TR.625x10		10"
TR.625x12		12"
TR.625x24		24"
TR.625x24-HDG	24"	
TR.75x6	3/4"	6"
TR.75x8		8"
TR.75x10		10"
TR.75x12		12"
TR.75x18-HDG		18"
TR.75x24		24"
TR.75x72-B7	72"	
TR.875x18	7/8"	18"
TR.875x24		24"
TR1x18	1"	18"
TR1x24		24"
TR1x24-B7		24"
TR1x72-B7		72"
TR1.125x24	1-1/8"	24"
TR1.25x24	1-1/4"	24"
TR1.25x72-B7	72"	
TR1.5x72-B7	1-1/2"	72"

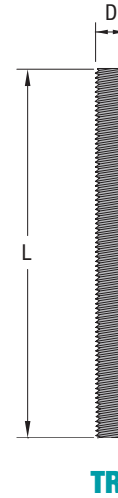

\*Other sizes, lengths, grades and coatings available upon request

## HEX NUTS (HN), HEAVY HEX NUTS (HHN) AND WELD NUT (WN)

### PRODUCT FEATURES:

Hex nuts (HN) and Heavy Hex Nuts (HHN) are used in various QuickTie™ assemblies (e.g. QuickTie™ Cables, Epoxy Anchors, Anchor Bolt, etc.).

Weld nuts (WN) are used to connect QuickTie™ Masonry cables to precast lintels.

### MATERIAL:

Carbon Steel, ASTM A563 Grade A & DH and Stainless Steel (SS)

### COATING:

Plain (Uncoated, N), Zinc Plated (Z), and HDG

Part No.	Bolt Size (D)*
HN.37N	3/8"
HN.37Z	
HN.37HDG	
HN.37SS	
HN.5N	1/2"
HN.5Z	
HN.5HDG	
HN.5SS	
HN.6N	5/8"
HN.6Z	
HN.6HDG	
HN.6SS	
HN.75N	3/4"
HN.75Z	
HN.75HDG	
HN.75SS	
HN.8N	7/8"
HN.8Z	
HN.8HDG	
HN.8SS	
HN1N	1"
HN1Z	
HN1HDG	
HN1.12Z	
HN1.25Z	1-1/8"
HN1.25Z	1-1/4"
HN1.25Z	5/8"
HHN.6Z	1"
HHN1Z-B7	1"
HHN1.25Z-B7	1-1/4"
WN.37Z	3/8"

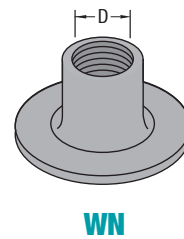
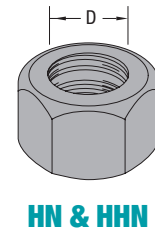

\*Other sizes and grades available upon request

## COUPLERS (C) & REDUCER COUPLERS (CR)

### PRODUCT FEATURES:

QuickTie™ Couplers (C) are used to connect QuickTie™ cables to foundation in anchor bolts and CMU saddle applications and to top plate in threaded rod application.

QuickTie™ Reducer Couplers (CR) are used when an application requires connection between different size components.

### MATERIAL:

Carbon Steel, Grade 2

### COATING:

Zinc Plated (Z)

Part No.	Rod Size (D)*	Height (H)
C.37Z	3/8"	1-1/8"
C.5Z	1/2"	1-1/4"
C.6Z	5/8"	2-1/8"
C.75Z	3/4"	2-1/4"
C.8Z	7/8"	2-1/2"
C1Z	1"	2-3/4"
C1.125Z	1-1/8"	3"
C1.25Z	1-1/4"	
C1.37Z	1-3/8"	
Part No.	D1-D2	Height (H)
CR.375-.75Z	3/4" to 3/8"	1"
CR.5-.37Z	1/2" to 3/8"	1-1/4"
CR.6-.37Z	5/8" to 3/8"	
CR.6-.5Z	5/8" to 1/2"	1-1/2"
CR.75-.5Z	3/4" to 1/2"	
CR.75-.62Z	3/4" to 5/8"	2-3/4"
CR.875-.75Z	7/8" to 3/4"	
CR1-1.25Z	1-1/4" to 1"	3"
CR1.125-.875Z	1-1/8" to 7/8"	

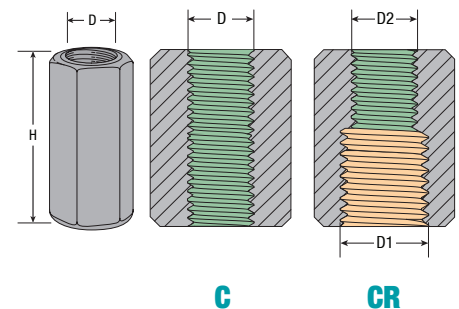

\*Other sizes, heights, grades and coatings available upon request

## BEARING PLATES / WASHERS (BPW)

### PRODUCT FEATURES:

QuickTie™ Bearing Plates/Washers are used for QuickTie™ Cables, Epoxy Anchors, Anchor Bolts, etc. Bearing Plates/Washers are available in various sizes and shapes (square, rectangle & round) with round and slotted holes.

### MATERIAL:

ASTM A36 Steel & A653 Grade 33 Steel

### NOMENCLATURE

#### BPW W x L - T Φ H F & BPR Φ F

BPW = Bearing Plates/Washers

R = Round Washer

W = Width in Decimal Inches

L = Length in Decimal Inches (for rectangular bearing plates only)

T = Thickness in 1/16 inches

Φ = Bolt Diameter in 1/8 inches

H = Hole Shape [None = Round, SQ = Square, SL = Slotted & TR = Triangle]

F = Finish [N = None, Z = Zinc Plated, H = HDG, G = Galvanized (G90 or G185), S = Stainless Steel and Px = Painted black (Pb), Painted gray (Pg), Painted white (Pw) & Painted gray primer (Pgp)]

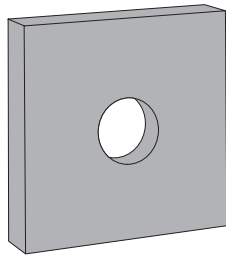

**BPW**

Hole Size = Bolt Diameter + 1/16"

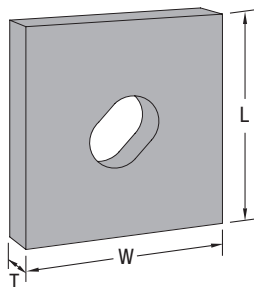

**BPW (Slotted)**

Slot Length = 1"  
Slot Width = Bolt Diameter + 1/16"

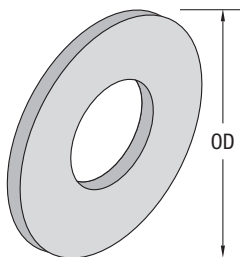

**BPR**

Hole Size = Bolt Diameter + 1/16"

## BEARING PLATES / WASHERS

Hole Shape, H	Bolt Size, Φ (in.)	Thick., T (in.)	Width, W (in.)	Length, L (in.)	Finish, F	Part No.	
<b>ROUND (BPW)</b>	3/8	3/16	2-1/4	2-1/4	Galvanized	<b>BPW2.25-33G</b>	
		1/4	2-3/4	2-3/4	Zinc Plated	<b>BPW2.75-43Z (Masonry)</b>	
	1/2	1/8	1-3/8	1-3/8	Galvanized	<b>BPW1.37-24G</b>	
					None	BPW2-24N	
			Galvanized	BPW2-24G			
		1/4	2	3	3	None	BPW3-44N
						Zinc Plated	BPW3-44Z
						HDG	BPW3-44H
	GEOMET	BPW3-44GEO					
	Zinc Plated	BPW3x4.5-44Z					
	3/8	3-1/2	3-1/2	Zinc Plated	<b>BPW3.5-64Z (Masonry)</b>		
	5/8	1/8	1-3/8	1-3/8	Galvanized	<b>BPW1.37-25G</b>	
					None	BPW2-25N	
		Galvanized	BPW2-25G				
		3/8	2-3/4	2-3/4	Zinc Plated	BPW2.75-65Z	
					Zinc Plated	BPW3-45Z	
		1/4	3	3	HDG	BPW3-45H	
					GEOMET	BPW3-45GEO	
					Zinc Plated	BPW3x4.5-45Z	
		3/8	4	4	Zinc Plated	<b>BPW4-65Z (Masonry)</b>	
					Zinc Plated	BPW4.5-65Z	
		3/4	1/8	2	2	Galvanized	BPW2-26G
						HDG	BPW2-26HDG
	3/16		2	2-1/4	Galvanized	BPW2x2.25-36G	
					Zinc Plated	BPW3-46Z	
	1/4		3	3	Zinc Plated	BPW3x4.5-46Z	
					None	BPW3-86N	
	1/2		3	3	Zinc Plated	<b>BPW3x4.5-86Z</b>	
					Painted Gray	BPW3.5-86Pg	
	5/8	4	4	Zinc Plated	<b>BPW4x6-106Z (Masonry)</b>		
Zinc Plated				BPW4-66Z			
7/8	1/4	3	3	Zinc Plated	BPW3-47Z		
				Painted Gray	BPW3.5-87Pg		
				Zinc Plated	BPW4-67Z		
1	1/2	3	3	Zinc Plated	BPW3-48Z		
				Zinc Plated	BPW3x4.5-88Z		
				None	BPW3.5-68N		
1-1/8	1/4	3	3	Zinc Plated	BPW3-49Z		
				Zinc Plated	BPW5.5x7.5-109Z		
				Zinc Plated	BPW3x4.5-810Z		
1-1/4	1/2	3-1/2	3	None	BPW3.5x5-810N		
				None	BPW3.5x5.5-810N		
	3/8	3	3	Zinc Plated	BPW3-610Z		
				None	BPW5.5x7.5-1210N		
	3/4	5-1/2	7-1/2	Zinc Plated	BPW5.5x7.5-1210Z		
				None	BPW3-44SLN		
<b>SLOTTED (BPW)</b>	1/2	1/4	3	3	Zinc Plated	<b>BPW3-44SLZ</b>	
					None	BPW3-45SLN	
	5/8	1/4	3	3	Zinc Plated	<b>BPW3-45SLZ</b>	
					Stainless Steel	BPW3-45SLS	
					Zinc Plated	BPW3x4.5-45SLZ	
					Zinc Plated	BPW5-45SLZ	

Hole Shape, H	Bolt Size, Φ (in.)	Nom.Thick., T (in.)	Outer Dia., OD (in.)	Finish, F	Part No.
<b>ROUND (BPR)</b>	1/4	0.051	3/4	Zinc Plated	BPR2Z
				HDG	BPR2H
				Stainless Steel	BPR2S
	3/8	0.064	1	Zinc Plated	BPR3Z
				HDG	BPR3H
				Stainless Steel	BPR3S
	1/2	0.086	1-3/8	Zinc Plated	BPR4Z
				HDG	BPR4H
				Stainless Steel	BPR4S
	5/8	0.108	1-3/4	Zinc Plated	BPR5Z
				HDG	BPR5H
				Stainless Steel	BPR5S
	3/4	0.122	2	Zinc Plated	BPR6Z
				HDG	BPR6H
				Stainless Steel	BPR6S
	7/8	0.136	2-1/4	Zinc Plated	BPR7Z
				HDG	BPR7H
				Stainless Steel	BPR7S
1	0.136	2-1/2	Zinc Plated	BPR8Z	
			HDG	BPR8H	
1-1/8	0.136	2-3/4	Zinc Plated	BPR9Z	
1-1/4	0.136	3	Zinc Plated	BPR10Z	
1-3/8	0.180	3-1/4	Zinc Plated	BPR11Z	

## BEARING PLATES / WASHERS

Part No.	Reference No. MiTek® Hardware (MH)	Width, W (in.)	Length, L (in.)	Thick., T (in.)	Bolt Size, Φ (in.)	Hole Shape, H	Finish, F
BPW3-410N *	BPW-5	3	3	1/4	1-1/4	Round	None
BPW3.2x3.3-612N *	BPW-6	3-1/4	3-3/8	3/8	1-1/2	Round	None
BPW3.2x4.3-812N	BPW-7		4-3/8	1/2		Round	None
BPW3.2x4.6-812N	BPW-8		4-5/8	1/2		Round	None
BPW3.2x5-1012N	BPW-9		5	5/8		Round	None
BPW3.2x5.8-1212N	BPW-11		5-7/8	3/4		Round	None
BPW3.2x7.8-1412N	BPW-15		7-7/8	7/8		Round	None
BPW3.2x10.2-2012N	BPW-20	3-1/2	10-1/4	1-1/4	1-1/2	Round	None
BPW3.5x11.7-2412N	BPW-25		11-3/4	1-1/2		Round	None
BPW3.5x14-2812N	BPW-30		14	1-3/4		Round	None
BPW5x5.8-1012N	BPW-17-6	5	5-7/8	5/8	1-1/2	Round	None
BPW5x9-1612N	BPW-27-6		9	1		Round	None
BPW5x12-2412N	BPW-36-6		12	1-1/2		Round	None
BPW5x14-2812N	BPW-43-6		14	1-3/4		Round	None
BPW5x15-3012N	BPW-46-6		15	1-7/8		Round	None

\* No 7/16" holes

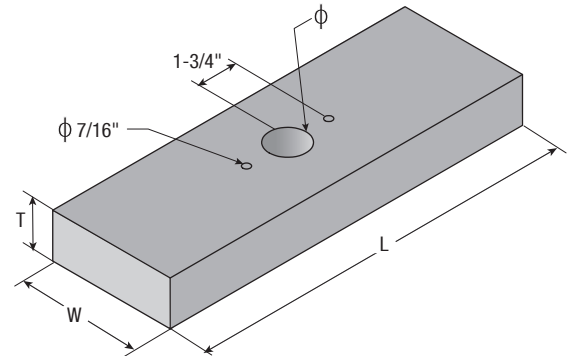

## BEARING PLATES / WASHERS WITH THREADED HOLE

Part No.*	Reference No. Simpson® Hardware (SH)	Width, W (in.)	Length, L (in.)	Thick., T (in.)	Tapped Hole Size, Φ (in.)	Finish, F
BPW3-125NT	ATS-SBCP5	3	3	3/4	5/8	None
BPW3-166NT	ATS-SBCP6			1	3/4	None
BPW3-127NT	ATS-SBCP7			3/4	7/8	None
BPW3-208NT	ATS-SBCP8			1-1/4	1	None
BPW3-169NT	ATS-SBCP9		1	1-1/8	None	
BPW3x5-2410NT	ATS-SBCP10		5	1-1/2	1-1/4	None
BPW3x6-2811NT	ATS-SBCP11		6	1-3/4	1-3/8	None
BPW3x7-2812NT	ATS-SBCP12		7	1-3/4	1-1/2	None

\* Bearing Plate (BPW) - ASTM A572 (Grade 50)

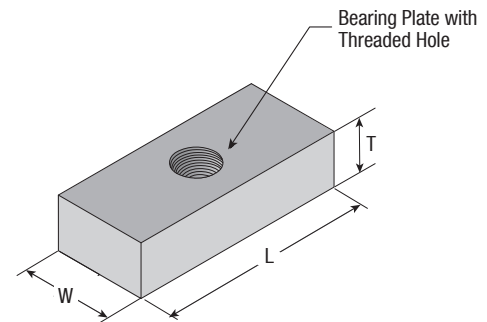

These Reference Numbers above are for the purpose of enabling our customers to identify the QuickTie™ alternative to specified product names, but the attributes of the products references (particularly load values) may differ from the QuickTie™ part. Please note that product comparison via Reference Numbers is for general application comparison only. Reference Numbers should not be used as an apples-to-apples substitution tool. Customers are solely responsible for comparing specific load values, fastener schedules, anchoring requirements, material specifications, and other factors when determining the suitability of use of any particular product. QuickTie™ makes no claim, stated or implied, of suitability for purpose or qualification for usage of our products that may be substituted for a specified product. Any specification, submittal, or change to a specified product should be approved in writing by the designer or Engineer of Record (EOR). MiTek® and Simpson Strong-Tie® are registered trademarks of their respective companies, with which QuickTie™ is unaffiliated, and neither of whom endorse or approve use of their product names in this catalog as “reference numbers”.

## FIRE CAULK

### PRODUCT FEATURES:

Ready-to-use, Metacaulk® MC 150+ Firestop Sealant is a general fire-rated elastomeric sealant for construction joints and through penetrations.

The sealant cures upon exposure to the atmosphere to form a firestop seal, which prevents spread of fire, smoke and noxious gas and when properly installed, it provides up to 4-hour fire protection.

### MATERIAL:

Refer to manufacturer's literature.

### INSTALLATION:

Refer to manufacturer's literature.

### CODE COMPLIANCE:

Refer to manufacturer's literature.



Part No.	Qty.
FCBALCOFIRESTOP	5 gal. Pail



Wood Installation Video



1 Drill bottom hole through plate and into concrete

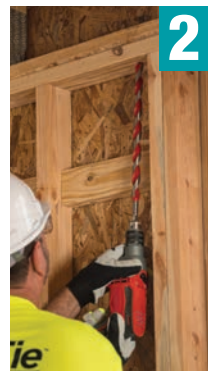

2 Drill top hole through the plate

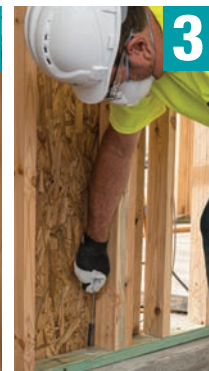

3 Blow out hole with compressed air; brush; blow again



4 Inject epoxy



5 Insert proper end of QuickTie™ in epoxy and allow to cure



6 Tighten QuickTie™ at top plate



7 Check the tension on the installed cables

# Wood Frame QuickTie™ Cables

U.S. PATENT NO. 6,014,843; Other Patents Pending

QUICKTIE™ CABLES

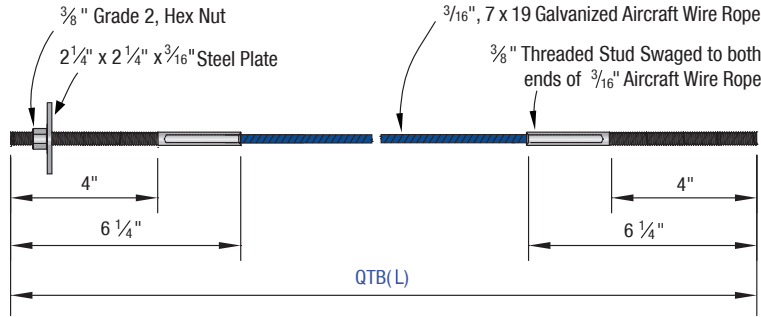

**QT(B)**  
**Blue**

**ALLOWABLE LOAD: 1,910 LB**

Wire Rope:  
 Breaking Strength : 4,200 lb  
 Hole Diameter:  
 Top Plate : 1"  
 Sill Plate : 5/8"  
 Concrete : 7/16"  
 Concrete:  
 Min. Comp. Strength : 2,500 psi  
 Min. Embedment : 4"  
 Min. Edge Distance : 2-1/4"

**TER 0910-01; FL #13468.1**

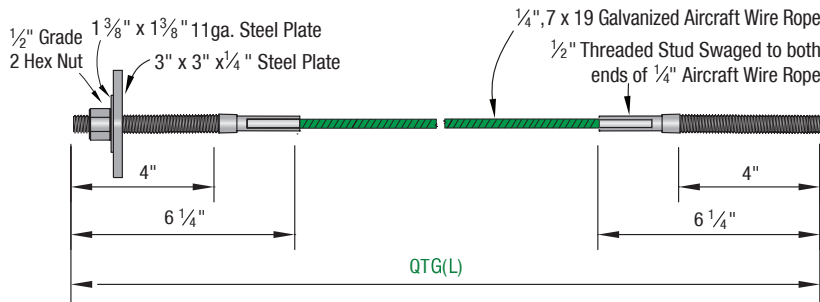

**QT(G)**  
**Green**

**ALLOWABLE LOAD: 3,180 LB**

Wire Rope:  
 Breaking Strength : 7,000 lb  
 Hole Diameter:  
 Top Plate : 1"  
 Sill Plate : 5/8"  
 Concrete : 9/16"  
 Concrete:  
 Min. Comp. Strength : 2,500 psi  
 Min. Embedment : 4"  
 Min. Edge Distance : 2-1/4"

**TER 0910-01; FL #13468.2**

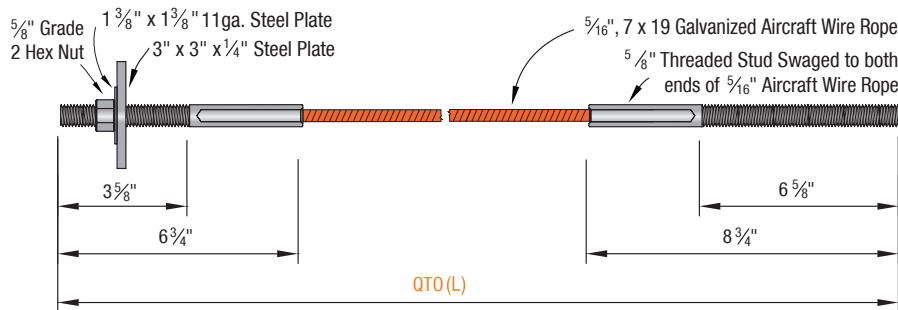

**QT(O)**  
**Orange**

**ALLOWABLE LOAD: 4,455 LB**

Wire Rope:  
 Breaking Strength : 9,800 lb  
 Hole Diameter:  
 Top Plate : 1"  
 Sill Plate : 3/4"  
 Concrete : 3/4"  
 Concrete:  
 Min. Comp. Strength : 2,500 psi  
 Min. Embedment : 6-5/8"  
 Min. Edge Distance : 3"

**TER 0910-01; FL #13468.3**

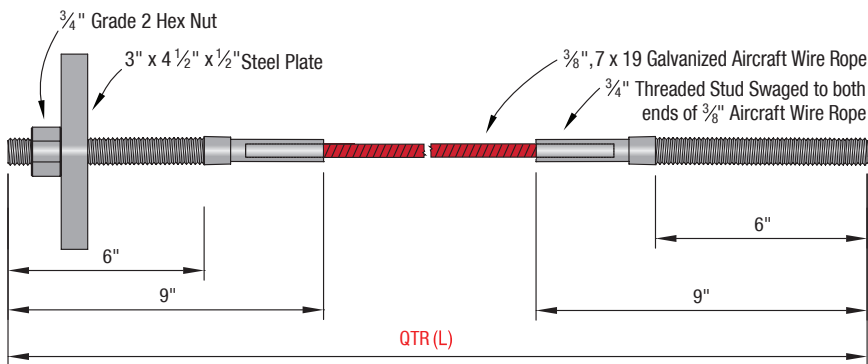

**QT(R)**  
**Red**

**ALLOWABLE LOAD: 6,545 LB**

Wire Rope:  
 Breaking Strength : 14,400 lb  
 Hole Diameter:  
 Top Plate : 1"  
 Sill Plate : 7/8"  
 Concrete : 7/8"  
 Concrete:  
 Min. Comp. Strength : 2,500 psi  
 Min. Embedment : 8-1/8"  
 Min. Edge Distance : 3-1/2"

**TER 0910-01; FL #13468.4**

## NOTES:

- QuickTie™ cables are manufactured in one inch (1") increments from 2' to 62' (Longer lengths available).
- QuickTie™ cables part numbers, QT(X)(L), correspond to the length (L) measured from the top of embed surface to the uppermost top plate. (Example: For L = 17'-1", QuickTie part numbers are QT(B)17.1 for 3/16"; QT(G)17.1 for 1/4"; QT(O)17.1 for 5/16" and, QT(R)17.1 for 3/8").
- To anchor the QuickTie™ System to the foundation, QE-1 Epoxy Adhesive is used (Refer to Page 26 for product information).
- Steel failure in testing was used to derive the allowable loads.

## OVERVIEW

All single and multi-story structures must resist lateral forces induced by wind or seismic events and transfer them from the roof and floor levels to the supporting soil below the foundation. To protect the structural integrity and safety of the occupants, a continuous load path must be present. A structural system with a series of interconnected structural elements (roofs, floors, beams, columns, load bearing walls, connections, footings, etc.) form the basis for a good load path. Lateral forces are often carried by components such as shear walls, roof/floor diaphragms, frames or a combination thereof, to transfer forces from the point of origin to the foundation.

A shear wall is commonly used in buildings made of wood frame, reinforced masonry, reinforced concrete, etc., to resist lateral forces parallel to the plane of the wall (i.e. in-plane forces). Shear walls are designed to resist uplift (wind) and overturning (wind and/or seismic) forces. The traditional wood-frame shear wall system includes various types of straps and hold-downs. Because of issues related to wood shrinkage and building settlement and growing trends towards designing and building multi-story structures, alternative shear wall system with threaded rod, threaded rod plus shrinkage compensation device, prestressed cable, etc. are developed and being widely used in the wood frame industry.

## QUICKTIE™ CABLES

QuickTie™ cables are used to resist uplift loads from the roof system, shear at the bottom plate and overturning forces at the ends of shear walls. When QuickTie™ cables are used, it is possible to omit all straps and construction hardware between the double top plates on the uppermost floor to the sole or sill plate on the lowest floor. Hurricane clips attaching the double top plate to the trusses must remain, however. A single QuickTie™ installed between the double top plate of the uppermost floor and the foundation serves adequately as a hold down for any shear wall. It replaces one hold down on the lowest floor and straps between floors at the second floor and third floor.

QuickTie™ cables are designed to securely anchor the top plate of the uppermost floor to the foundation. QuickTie™ cables are made of 7x19 type galvanized aircraft wire rope with factory installed threaded studs swaged at each end. QuickTie™ cables are attached to the foundation with mechanical or chemical anchor attachments and to the top plate using steel plates or special washers and threaded hex nuts. The bottom end of the QuickTie™ is anchored to the foundation by drilling a hole through the treated lumber sole plate into the concrete slab/foundation and inserting the threaded stud into the hole after it has been cleaned and filled with a special QuickTie™ Epoxy adhesive. The correct embedment of the threaded stud is easily verified by measuring the length of the threaded stud protruding above the top of the treated lumber sole plate. Also protruding above the top of the sole plate is the excess epoxy from the hole into the concrete. The protruding epoxy indicates that the threaded stud is completely encased from the bottom of the hole in the concrete to the top of the treated lumber sole plate. This is extremely important because the threaded stud is now

isolated against the corrosive effects of the treated lumber on unprotected steel. Refer to Page 31 and Page 41 for the details of various QuickTie™ cables used for wood and masonry applications, respectively.

- QuickTie™ cables are flexible and elastic
- Each QuickTie™ is manufactured to the exact length required for its intended location in the field
- QuickTie™ cables are installed only by factory trained and licensed installers
- By pre-stressing to a design load for 115 - 215 mph winds, QuickTie™ cables are designed to allow zero movement until the forces applied, (wind or seismic) reach the pre-stress load. That's why QuickTie™ cables keep your home "Stronger in the Storm.™" They simply cinch the top plate to the building's foundation!
- QuickTie™ cables are easy to inspect. At installation, the pre-stress load exceeds the design load—therefore, "proof-testing" each QuickTie™ when installed, and not during a storm!

## PRE-STRESSING QUICKTIE™ CABLES

Shrinkage and movement are a common problem in wood framed buildings; a problem which the old method of straps and threaded anchors simply do not address. When the building is exposed to dead loads as it is being built, deflections develop in these products, creating a "loose" load path to the foundation. Loose structural connectors allow movement which causes the building to be "pulled apart" until these parts become tight, during high winds. This movement is also one of the major contributors to drywall and stucco cracks and bowing trim. Because the wire stretches, it can be "pre-stressed" to produce zero movement and compensate for building settling and long-term wood shrinkage.

When using elastic QuickTie™ cables as hold downs, the wood columns of the shear walls are pre-stressed. The columns are compressed between the foundation and the uppermost wood top plate. The wall components are subjected to a greater compressive load than walls constructed with conventional hardware. Even when the wall "shrinks" or reduced in height due to weather or loading conditions, the force on the top plate from the QuickTie™ cables is only reduced slightly. When the QuickTie™ cables are installed, by applying an extra compression force compensates the anticipated shortening or shrinkage. When the anticipated shortening is reached, the QuickTie™ force has been reduced to the design force.

The real advantage of the QuickTie™ system is that there can be no vertical displacement or deflection of the top plate until the magnitude of the pre-compression force is exceeded. Stated another way, no vertical movement will occur in the top plate until the design wind velocity has been exceeded. And finally, because the tension applied to the QuickTie™ at the time of construction equals the design load, the QuickTie™ installation has been proof tested to the design load. No other system on the market does that.

At times, overturning loads can be very high. Studs at shear wall ends shall be sized to resist the additional compression load from the pre-stressed QuickTie™

cables. The Table on Page 36 indicates the minimum number of studs required when using a specific QuickTie™ as a holddown. The stud configurations below the table show possible stud configurations (refer to the notes and illustrations for additional information). Spacing of the QuickTie™ cables varies and is dependent on the uplift expected from the roof trusses, rafters or joists. Refer to Table on Page 33 for spacing of QuickTie™ cables to resist wind uplift.

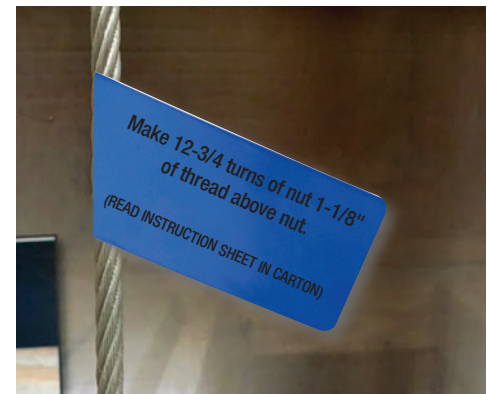

# Uplift Spacing Table

## QuickTie™ Placement

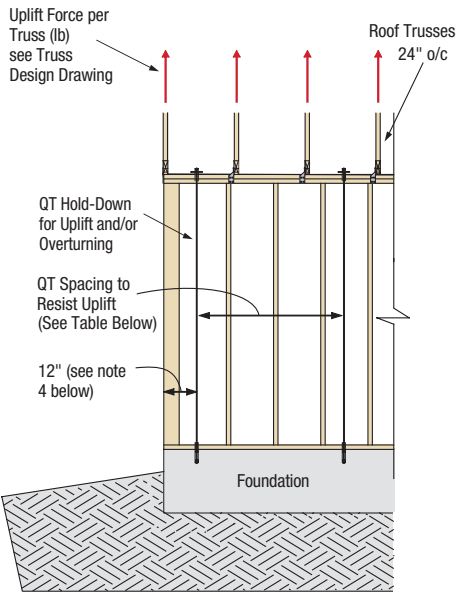

## Header Tie-Down Requirements

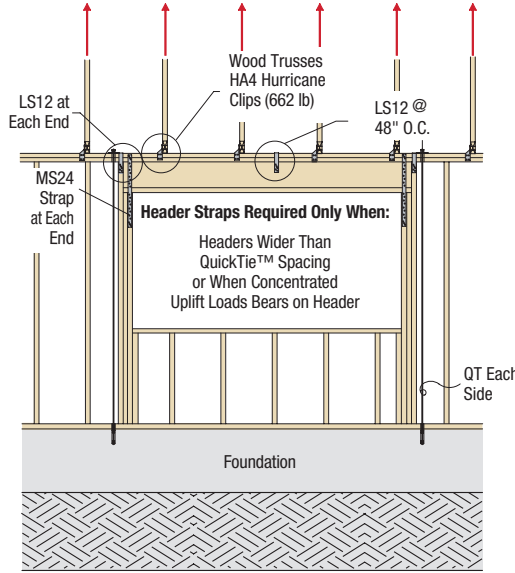

## Girder Tie-Downs

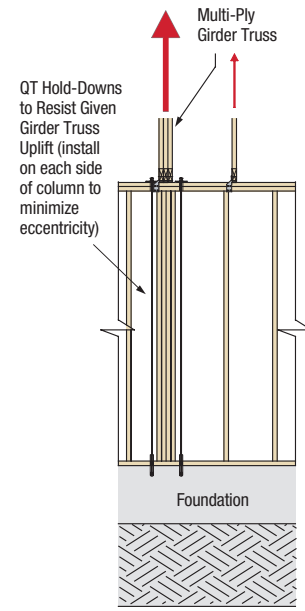

### NOTES:

1. Sheathing for shear walls removed for clarity.
2. All QuickTie™ cables shall be installed according to these specifications unless designed and certified by a registered design professional.
3. Install QuickTie™ cables at each end of all shear wall segments. More than one QuickTie™ may be required to resist combined forces due to uplift and overturning.
4. Refer to Table for maximum spacing requirements for QuickTie™ cables used to resist uplifts only. Install one QuickTie™ within 12" of each load bearing corner (one side of corner, preferably the side where the top plates lap over the other wall.)
5. Allowable loads provided in this figure are for QuickTie™ System only. Building designer must verify that the wall structural framing elements are capable of transferring the loads to the QTS.
6. See header connection schedule for connections required for headers 8'-0" and greater.
7. Use only QuickTie™ System materials as supplied by Quick Tie Products, Inc.

## QUICKTIE™ SPACING AND QT CONNECTORS FOR RESISTING UPLIFT FORCES

QT Spacing ft.-in. (in.)	TRUSSES/RAFTERS @ 16" O.C.				TRUSSES/RAFTERS @ 24" O.C.			
	Allowable Truss Uplift Load with QTB (lb)	No. & Type of Truss-to-Top Plate QT Connectors	Allowable Truss Uplift Load with QTG (lb)	No. & Type of Truss-to-Top Plate QT Connectors	Allowable Truss Uplift Load with QTB (lb)	No. & Type of Truss-to-Top Plate QT Connectors	Allowable Truss Uplift Load with QTG (lb)	No. & Type of Truss-to-Top Plate QT Connectors
1'-4" (16")	1,910	(2) HTS16	3,180	(2) HTS16	1,910	(2) HTS16	3,180	(2) HTS16
2'-0" (24")	1,275	(2) HA6	2,120	(2) HTS16	1,910	(2) HTS16	3,180	(2) HTS16
2'-8" (32")	955	(2) HA6	1,590	(1) HTS16	1,435	(1) HTS16	2,385	(2) HTS16
4'-0" (48")	635	(1) HA6	1,060	(2) HA6	955	(2) HA6	1,590	(1) HTS16
5'-4" (64")	480	(1) HA6	795	(2) HA6	715	(2) HA6	1,195	(2) HA6
6'-0" (72")	425	(1) HA6	705	(2) HA6	635	(1) HA6	1,060	(2) HA6
6'-8" (80")	380	(1) HA6	635	(1) HA6	575	(1) HA6	955	(2) HA6
8'-0" (96")	320	(1) HA6	530	(1) HA6	400	(1) HA6	795	(2) HA6

### NOTES:

1. Use only QuickTie™ System materials as specified and supplied by Quick Tie Products, Inc.
2. The allowable load for QTB is 1,910 lb and QTG is 3,180 lb.
3. Minimum requirements for QT: Edge distance = 2-1/4 in., End distance = 6 in., Embedment = 4 in. and Concrete compressive strength = 2,500 psi.
4. Loads require a minimum 1/2" thick gypsum wall board on each side of the studs with 1-1/2" long wallboard nails spaced at 6" o.c. at edges and 12" o.c. in the field.
5. If QT's spaced at 4 ft or greater and no structural sheathing is provided, (1) LS18 strap shall be installed at mid-spacing to prevent top plate bending.
6. The allowable uplift load ( $C_D = 1.6$ ) per connector with Southern Pine ( $SG = 0.55$ ) lumber and 10d x 1-1/2" nails:
  - a. HA6 = 650 lb and HTS16 = 1,665 lb.

## QuickTie™ to Threaded Rod Extension at Top Plate

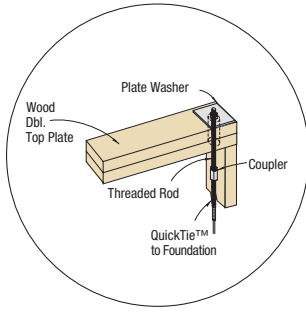

## QuickTie™ to Masonry and Wood Wall

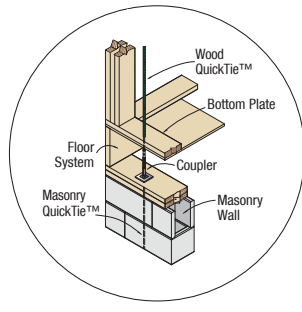

## QuickTie™ to CMU Saddle Assembly on Top of CMU

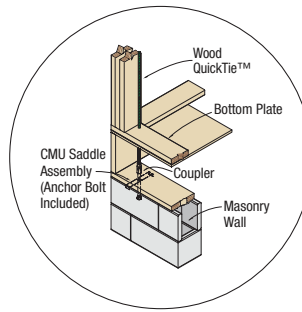

## Anchor Chair

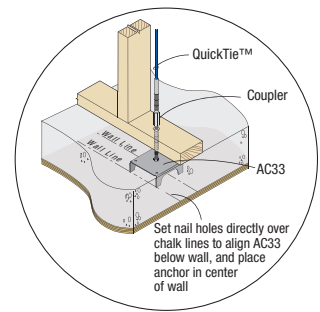

## QE-1 ALLOWABLE TENSION VALUES FOR QUICKTIE™ SYSTEMS (QT)

Cable Type	Cable Diameter	Minimum Edge Distance, $c_{a1}$	Minimum End Distance, $c_{a2}$	Minimum Embedment Depth, $h_{ef}$	Allowable QT System Tension Loads <sup>1,2,3</sup>
	(in.)	(in.)	(in.)	(in.)	(lb)
QTB (Blue)	3/16	2-1/4	6	4	1,910
QTG (Green)	1/4	2-1/4	6	4	3,180
QTO (Orange)	5/16	3	6	6-5/8	4,455
QTR (Red)	3/8	3-1/2	6	8-1/8	6,545

### NOTES:

1. Allowable QT System tension loads are based on test results with cables installed in uncracked concrete and no supplementary reinforcement.
2. Minimum 28-day concrete compressive strength is 2,500 psi.

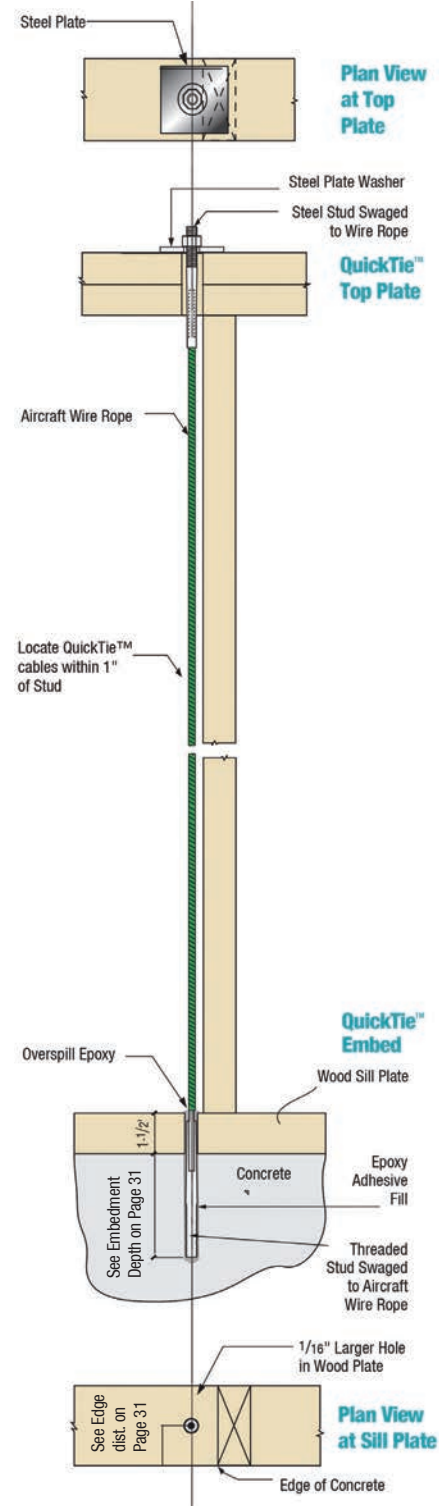
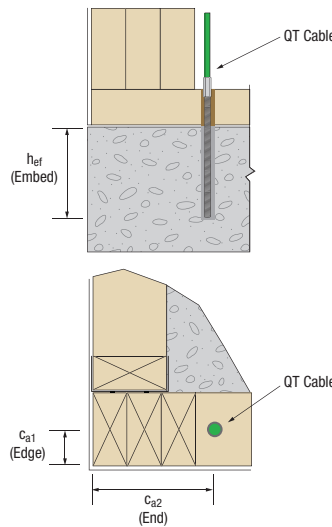

## ALLOWABLE LOADS FOR QUICKTIE™ CABLES UNDER COMBINED TENSION AND SHEAR

Item No	Tension (lb)	Shear (lb)		
	T	F1	F2	F3
QTB	1,910	1,130	1,450	510
QTG	3,180	1,395	1,785	620

### NOTES:

1. Allowable loads are based on the test results with SP #2 lumber.
2. T = Cable Tension  
F1 = Parallel to Sill Plate (in-plane shear)  
F2 = Perpendicular to Sill Plate (force acting from outside of wall)  
F3 = Perpendicular to Sill Plate (force acting from inside of wall)
3. Minimum concrete compression strength,  $F_c' = 2,500$  psi
4. Minimum edge distance = 2-1/4", Min. end distance = 6-1/2" & Min. embedment = 4"
5. Frictional resistance due to self-weight of building components are not included.
6. Overspill epoxy per installation instructions.

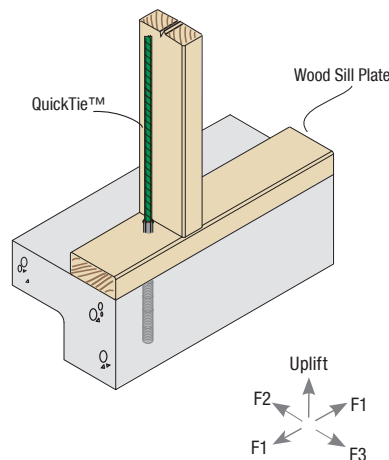

# QuickTie™ Beam Connector

## QUICKTIE™ BEAM CONNECTOR (BPBC)

### PRODUCT FEATURES:

QuickTie™ Beam Connectors (BPBC) are used to attach the QuickTie™ Cables directly to the beam under the bottom plate. The part includes washer and wood screws.

### INSTALLATION:

- Use all specified fasteners to achieve the required cable load values.
- A minimum thread penetration of 3" into the beam is required.

Part No.	Description
BPBC2.25-33N (QTB)	2-1/4" x 2-1/4" x 3/16" Washer & 3/8" Hex Nut
BPBC2.25-33NS (QTB)	2-1/4" x 2-1/4" x 3/16" Washer, 3/8" Hex Nut & (4) SWH5 Wood Screws
BPBC2.25-44N (QTG)	2-1/4" x 2-1/4" x 1/4" Washer & 1/2" Hex Nut
BPBC2.25-44NS (QTG)	2-1/4" x 2-1/4" x 1/4" Washer, 1/2" Hex Nut & (6) SWH5 Wood Screws
BPBC2.25-45N (QTO)	2-1/4" x 2-1/4" x 1/4" Washer & 5/8" Hex Nut
BPBC2.25-45NS (QTO)	2-1/4" x 2-1/4" x 1/4" Washer, 5/8" Hex Nut & (6) SWH5 Wood Screws

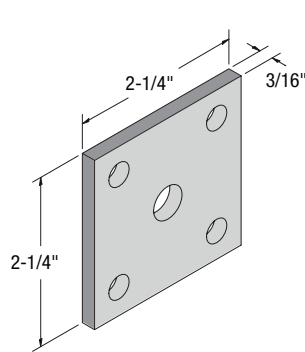

**BPBC2.25-33N (QTB)**  
**BPBC2.25-33NS (QTB)**

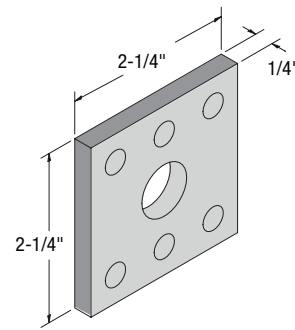

**BPBC2.25-44N (QTG)**  
**BPBC2.25-44NS (QTG)**  
**BPBC2.25-45N (QTO)**  
**BPBC2.25-45NS (QTO)**

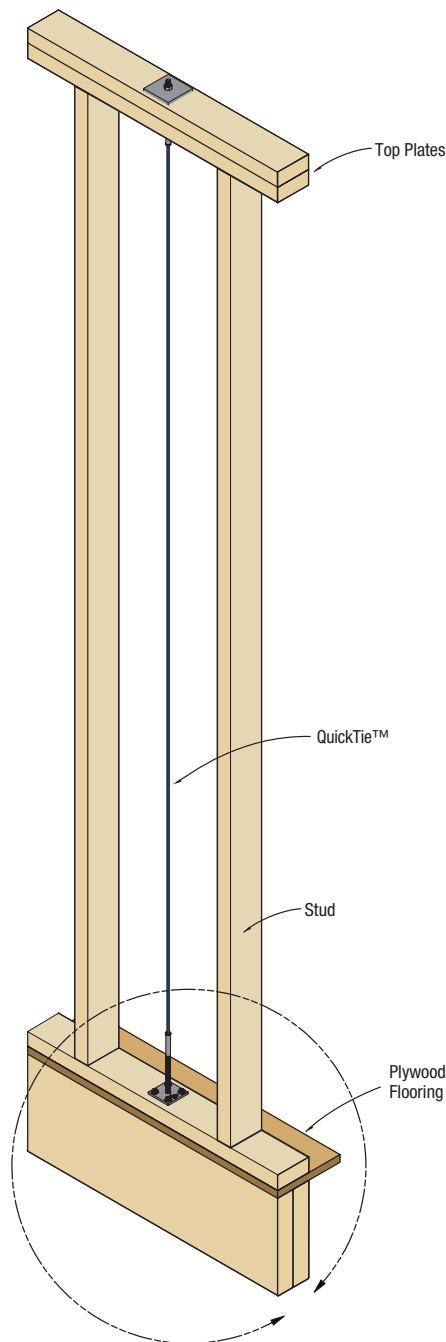
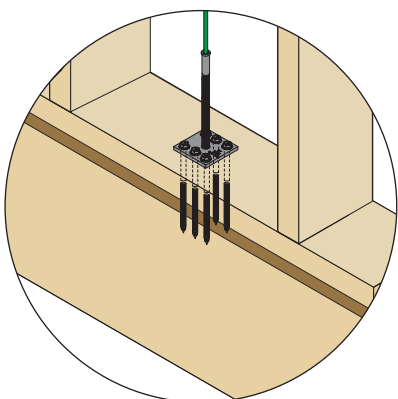
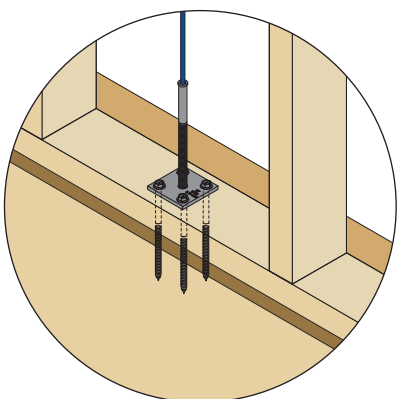
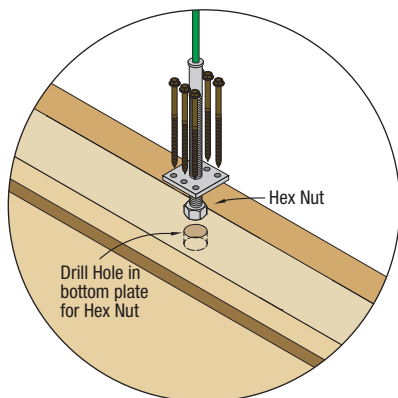
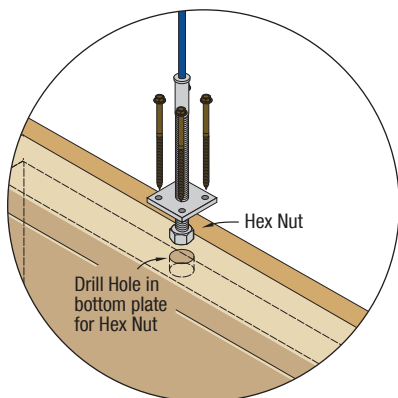

**NOTE:** A minimum thread penetration of 3" into the beam is required.

## COMPRESSION STUD REQUIREMENTS

Number of Studs Required at Shear Wall Ends to Receive QuickTie™ Compression Loads							
QuickTie™	QT Allowable Load (lb)	SP			SPF		
		2x4	3x4	2x6	2x4	3x4	2x6
1-QTB	1,910	1	1	1	1	1	1
1-QTG	3,180	2	1	1	2	1	1
1-QTO	4,455	3	2	2	4	3	2
1-QTR	6,545	3	2	2	5	3	2
2-QTO	8,910	6	4	2	8	3	2
2-QTR	13,090	8	5	4	10	6	4

### NOTES:

- The design values of SP, No. 2 ( $F_b=1,100$  psi,  $F_c=1,450$  ksi,  $E=1,400$  ksi) and SPF, No. 2 ( $F_b=875$  psi,  $F_c=1,150$  psi,  $E=1,400$  ksi) are based on the latest edition of NDS®.
- The tabulated values are based on a nominal 10 foot plate height, except 9'6" plate height for 1-QTB installed with 2x4.
- The table indicates the minimum number of studs required when using specific QuickTie™ cable(s) as a hold-down for shear walls, not for uplift. The number of studs shown in the table may be reduced when corners, tees, jack studs, and king studs are located next to the QuickTie™ hold-down(s).

## COMPRESSION STUD CONFIGURATION

### (1-QTB or 1-QTG) 2 Stud Configurations

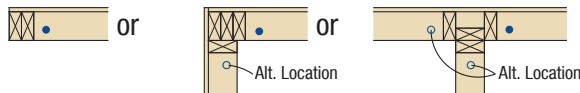

### (2-QTB) 3 Stud Configurations

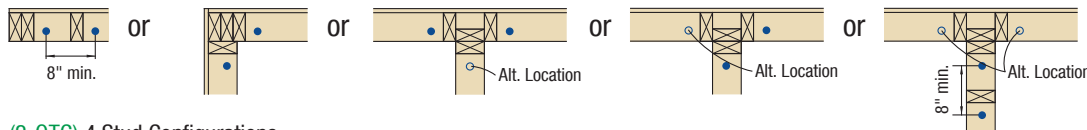

### (2-QTG) 4 Stud Configurations

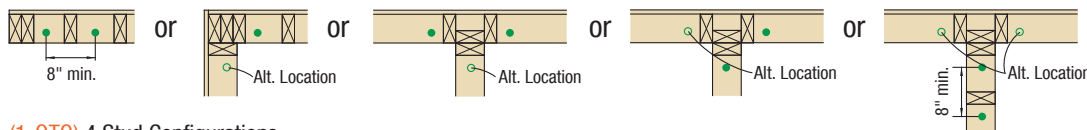

### (1-QTO) 4 Stud Configurations

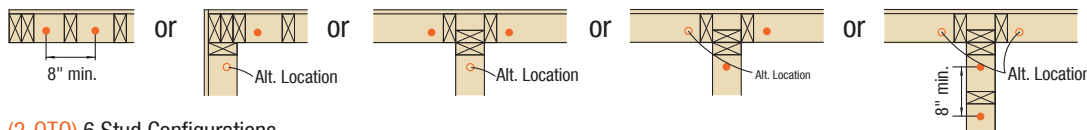

### (2-QTO) 6 Stud Configurations



### (1-QTR) 5 Stud Configurations



### (2-QTR) 8 Stud Configurations

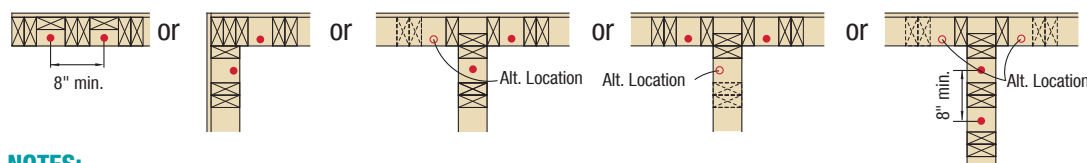

### NOTES:

- The stud configuration illustrations shown are only possible configurations to meet the compression loads. These illustrations do not indicate that additional studs must be added. Corners, tees, jacks, and king studs can be used as required compression studs when located next to QuickTie™ cables.
- The design professional should check for the correct number of compression studs in combination with other loads developed by the structural designer.
- QuickTie™ cable(s) are hold-downs only. Shear walls shall be designed by the design professional using proper framing, sheathing, and fasteners to resist wind or seismic loads.
- Epoxy anchors should be placed between QuickTie™ hold-downs to satisfy horizontal loads at the bottom plate.
- To resist loads higher than shown here, additional QuickTie™ cable(s) and studs can be added.
- When used as a hold-down, additional QuickTie™ cable(s) are not needed at the same location to meet roof uplift loads as shown on page 33.
- Where wood walls are installed over reinforced masonry walls, the elastic QuickTie™ cable(s) may be anchored into formed concrete tie beams.
- When grouted masonry tie beams comprise the top course of reinforced masonry walls, the elastic QuickTie™ cable(s) shall be coupled to anchor bolts that have been hooked and wired under a continuous reinforcing bar, located at least 5 inches below the top of the tie beam. Concrete is then cast into the tie beam. Mechanical or chemical anchors may be used as long as they are installed into a minimum 2,500 psi concrete mix fill, and meet the edge and embedment requirements.

# Typical Multi-Story Installation

## QUICKTIE™ SHEAR WALL HOLD-DOWN APPLICATIONS

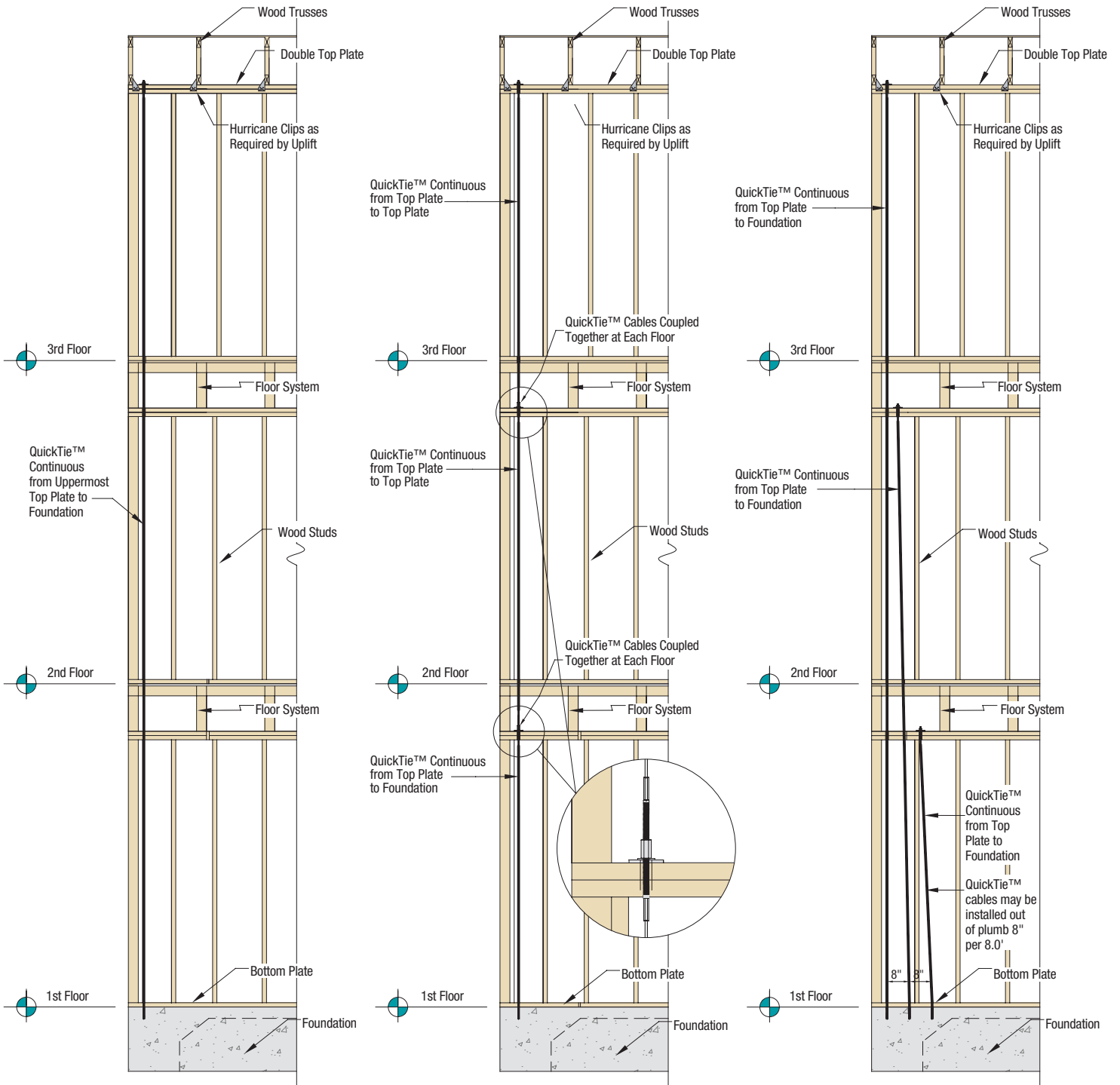

**OPTION 1 (Typical)**  
**[Single QuickTie™**  
**Connected from Roof Level**  
**to Foundation]**

**OPTION 2**  
**[Multiple QuickTie™ Cables**  
**Connected Intermediately at**  
**Each Floor Level]**

**OPTION 3**  
**[Multiple QuickTie™ Cables**  
**Connected from Each Floor Level**  
**[Offset] to Foundation]**

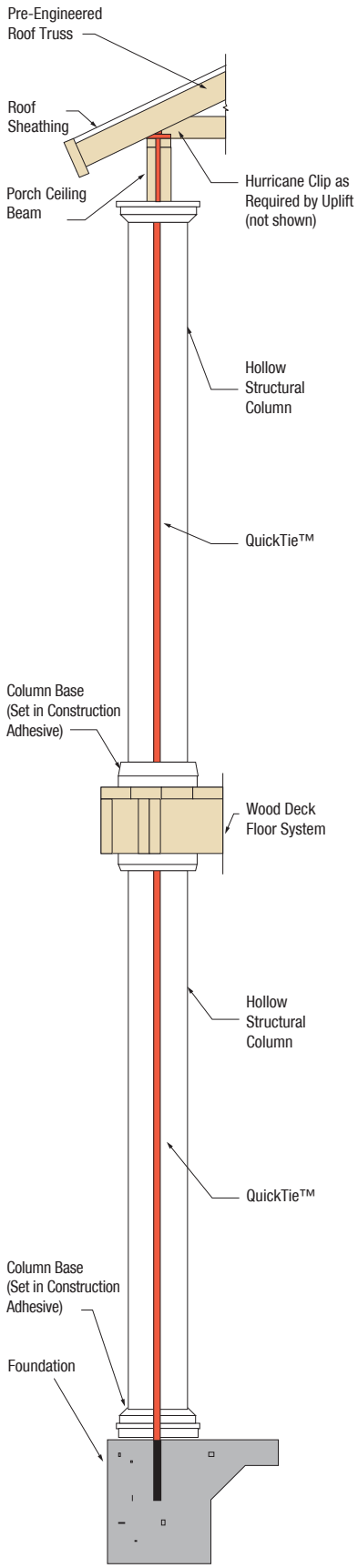

- KIT CONTENTS:**
1. QuickTie™ Cable with washer and nut
  2. Fishing Line to feed/pull cable
  3. Installation Instructions

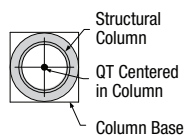
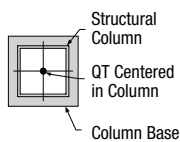
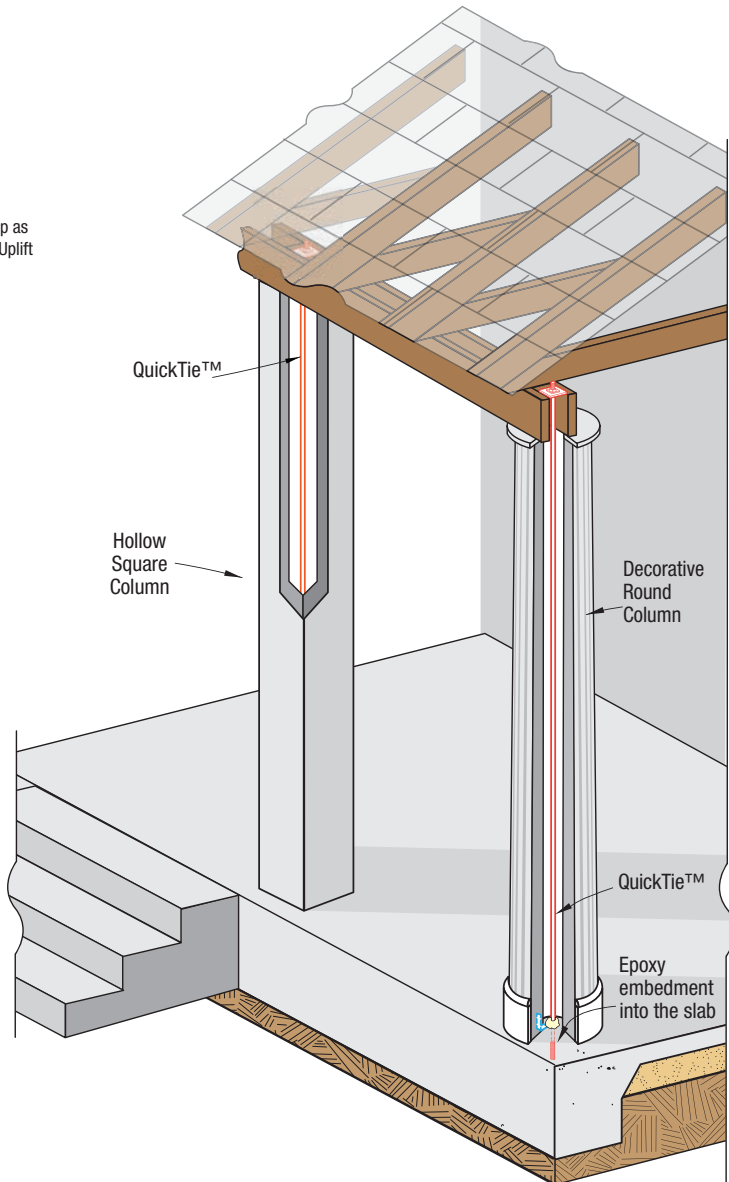
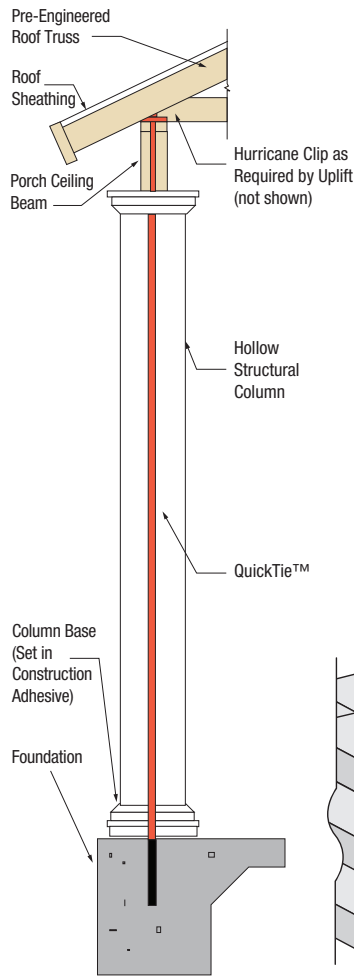

# QuickTie™ Portal Frame Details

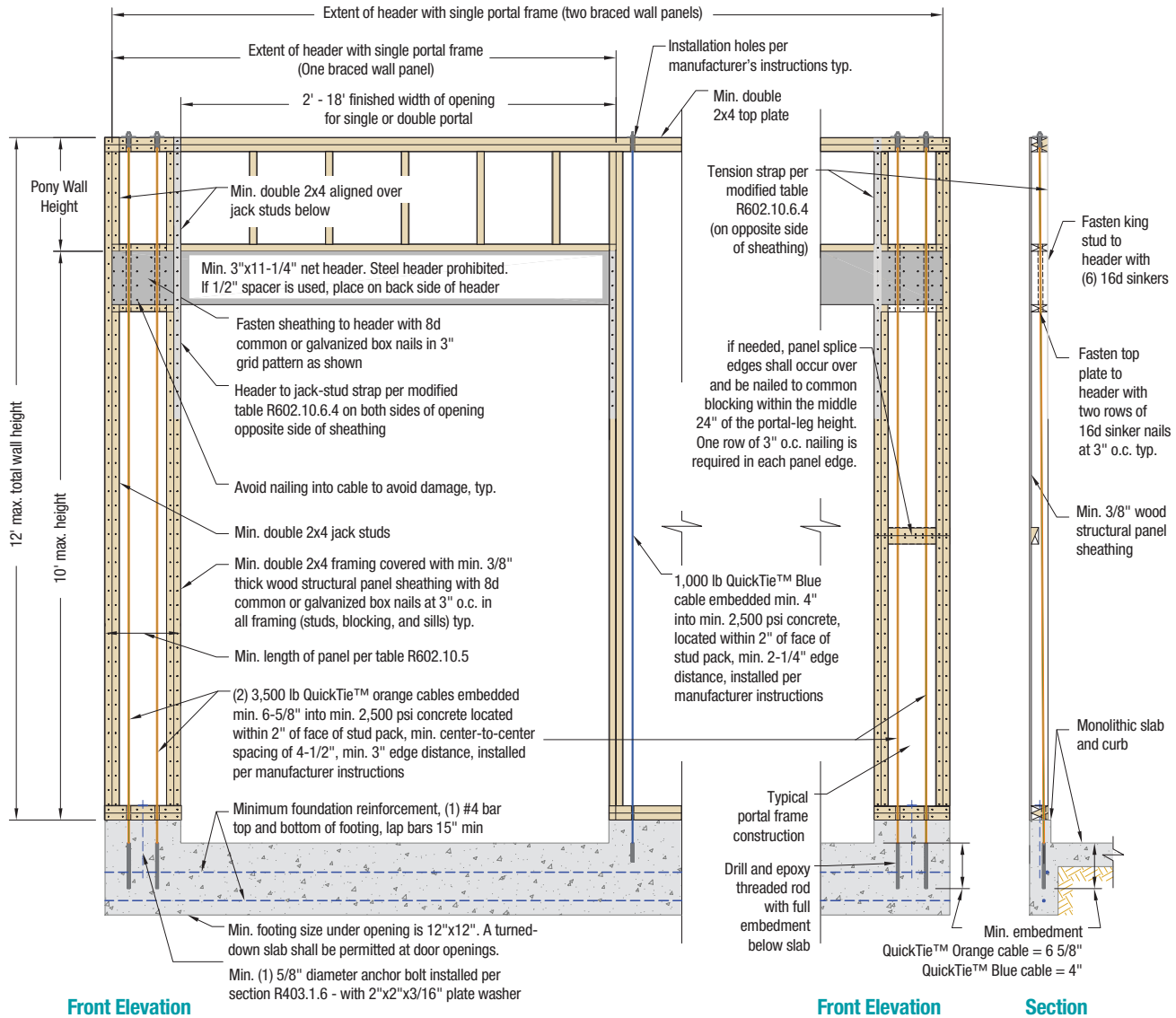

## MODIFIED TABLE R602.10.6.4 TENSION STRAP CAPACITY FOR RESISTING WIND PRESSURES PERPENDICULAR TO METHOD PFH

MINIMUM WALL STUD FRAMING NOMINAL SIZE AND GRADE	MAXIMUM PONY WALL HEIGHT (FT)	MAXIMUM TOTAL WALL HEIGHT (FT)	MAXIMUM OPENING WIDTH (FT)	ADJACENT TO QUICKTIE™ BLUE CABLE TENSION STRAP CAPACITY REQUIRED (LB) <sup>1,2,3</sup>						ADJACENT TO QUICKTIE™ ORANGE CABLE TENSION STRAP CAPACITY REQUIRED (LB) <sup>1,2,3</sup>						
				Ultimate Design Wind Speed, Vult (mph)						Ultimate Design Wind Speed, Vult (mph)						
				110	115	130	110	115	130	110	115	130	110	115	130	
				Exposure B			Exposure C			Exposure B			Exposure C			
2X4 No. 2 Grade	0	10	18	NR	NR	NR	NR	NR	NR	NR	NR	NR	NR	NR	NR	
			9	NR	NR	NR	NR	NR	750	NR	NR	NR	NR	NR	NR	
	1	10	16	NR	NR	1,050	1,075	1,500	2,950	NR	NR	NR	NR	NR	450	
			18	NR	275	1,375	1,400	1,850	DR	NR	NR	NR	NR	NR	DR	
	2	10	9	NR	NR	475	500	875	2,125	NR	NR	NR	NR	NR	NR	
			16	775	1,175	2,525	2,550	3,125	DR	NR	NR	NR	NR	625	DR	
	2	12	18	1,075	1,500	2,950	2,975	DR	DR	NR	NR	450	475	DR	DR	
			9	150	500	1,650	1,675	2,175	DR	NR	NR	NR	NR	NR	DR	
	4	12	16	1,875	2,375	DR	DR	DR	DR	NR	NR	DR	DR	DR	DR	
			18	2,425	2,975	DR	DR	DR	DR	NR	475	DR	DR	DR	DR	
	2X6 Stud Grade	2	12	9	1,275	1,750	DR	DR	DR	DR	NR	NR	DR	DR	DR	DR
				12	2,225	2,775	DR	DR	DR	DR	NR	275	DR	DR	DR	DR
4		12	9	NR	NR	700	700	1,025	2,050	NR	NR	NR	NR	NR	NR	
			16	825	1,150	2,225	2,225	2,675	DR	NR	NR	NR	NR	175	DR	
4		12	18	1,200	1,550	2,725	2,750	DR	DR	NR	NR	225	250	DR	DR	
			9	450	750	1,700	1,725	2,125	DR	NR	NR	NR	NR	NR	DR	
4	12	16	1,050	1,400	DR	DR	DR	DR	NR	NR	DR	DR	DR	DR		
		18	2,350	2,800	DR	DR	DR	DR	NR	300	DR	DR	DR	DR		

### NOTES:

- DR = Design Required
- NR = Not Required
- Straps shall be installed in accordance with manufacturer's recommendations.



Masonry Installation Video



1

Layout QuickTie locations



2

Tack Anchor Bolt Assemblies at each location



3

Pour concrete



4

Lay CMU first course with knockouts located at each anchor bolt. (Knockouts may be placed inside or outside)



5

Finish laying CMU block wall in running bond pattern



6

Install 2x8 Southern Pine wood top plates (pressure treated bottom plate) continuously at top of wall



7

Check truss layout to ensure no conflicts with QuickTie locations



8

Drill holes in top plates above each anchor bolt location



9

Feed QuickTie through the top plates at each anchor bolt location



10

Connect each QuickTie to the anchor bolt in foundation using coupler or reduced coupler



11

Prestress QuickTie to specified load using Masonry tension device



## QTBM Blue

**ALLOWABLE LOAD: 2,102 LB**  
**PRESTRESS LOAD: 2,940 LB**

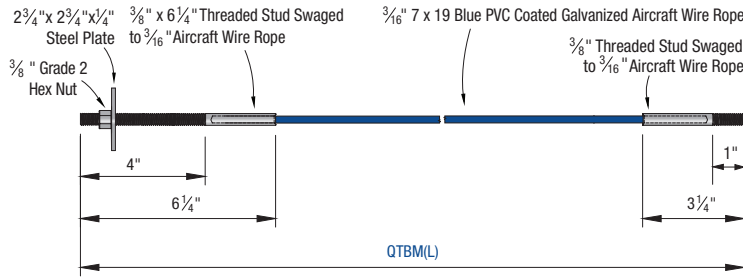

Epoxy Application

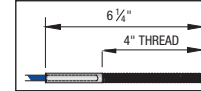

Wire Rope:  
Breaking Strength : 4,200 lb  
Hole Diameter:  
Top Plate : 1"  
Concrete : 7/16"  
Concrete:  
Min. Comp. Strength : 2,500 psi  
Min. Embedment : 4"  
Min. Edge Distance : 4"

**TER 1404-06; FL #17106**

## QTGM Green

**ALLOWABLE LOAD: 3,504 LB**  
**PRESTRESS LOAD: 4,900 LB**

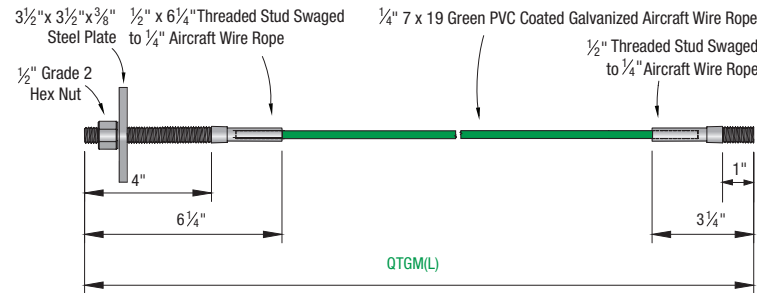

Epoxy Application

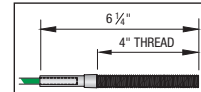

Wire Rope:  
Breaking Strength : 7,000 lb  
Hole Diameter:  
Top Plate : 1"  
Concrete : 9/16"  
Concrete:  
Min. Comp. Strength : 2,500 psi  
Min. Embedment : 4"  
Min. Edge Distance : 4"

**TER 1404-06; FL #17106**

## QTOM Orange

**ALLOWABLE LOAD: 4,905 LB**  
**PRESTRESS LOAD: 6,860 LB**

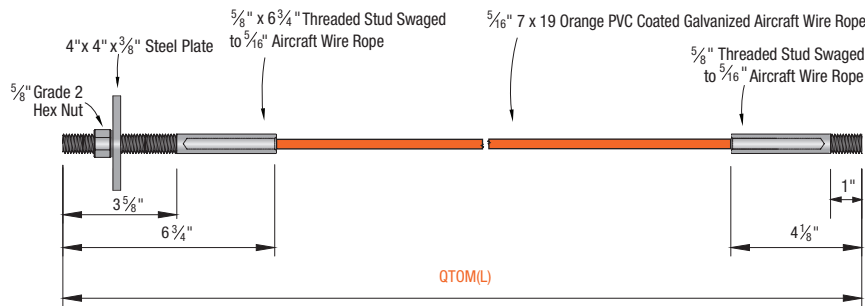

Epoxy Application

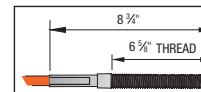

Wire Rope:  
Breaking Strength : 9,800 lb  
Hole Diameter:  
Top Plate : 1"  
Concrete : 3/4"  
Concrete:  
Min. Comp. Strength : 2,500 psi  
Min. Embedment : 6-5/8"  
Min. Edge Distance : 4"

**TER 1404-06; FL #17106**

## QTRM Red

**ALLOWABLE LOAD: 7,207 LB**  
**PRESTRESS LOAD: 10,080 LB**

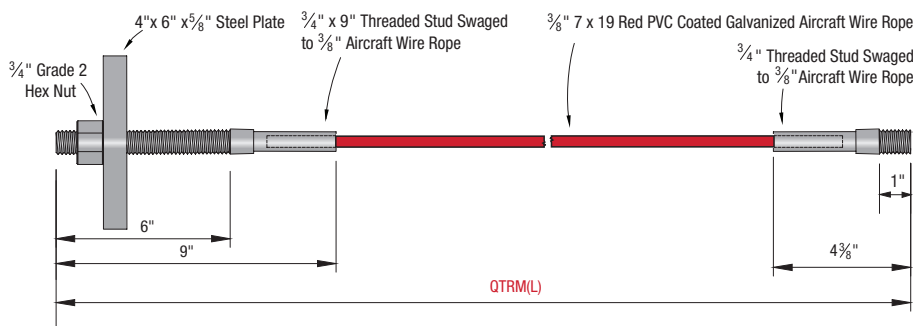

Epoxy Application

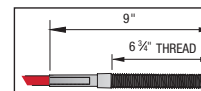

Wire Rope:  
Breaking Strength : 14,400 lb  
Hole Diameter:  
Top Plate : 1"  
Concrete : 7/8"  
Concrete:  
Min. Comp. Strength : 2,500 psi  
Min. Embedment : 8-1/8"  
Min. Edge Distance : 4"

**TER 1404-06; FL #17106**

### NOTES:

- Masonry Ties are manufactured in one inch (1") increments from 2' to 30'.
- Masonry Tie part numbers, QTXM(L), correspond to the length (L) measured from the top of embed surface to the uppermost top plate.  
(Example: For L = 17'-1", QuickTie™ part numbers are QTBM17.1 for 3/16"; QTGM17.1 for 1/4"; QTOM17.1 for 5/16" and, QTRM17.1 for 3/8").
- To anchor the QuickTie™ System to the foundation, QE-1 Epoxy Adhesive is used (Refer to Page 26 for product information).

# Typical Masonry Installation



Masonry Installation Video

**PRODUCT FEATURES:**

The QuickTie™ Masonry System is a post-tension masonry wall anchoring system consisting of PVC-coated wire rope with threaded studs swaged to each end. The bottom threaded stud of the wire rope is fed through a pre-drilled hole at the double top plate, and then coupled to an embedded anchor bolt, or, epoxied into cured concrete to anchor it to the foundation. Once secured to the foundation, the cable is tensioned from the top plate of the wall to a specified load by tightening a hex nut down the upper threaded stud onto a steel base plate. This provides a continuous load path hold down resistance for the wall. Trusses are connected with QuickTie™ Connectors to provide distribution of load to the QuickTie™ System.

**THE QuickTie ADVANTAGE:**

- Less Expensive than Conventional Masonry
- 30% Stronger than Conventional Masonry
- Meets Building Code Requirements
- Pre-Stressing Helps Prevent Stair Step Cracks
- Quicker – Cuts Days Out of the Construction Cycle
- Installs in Hours (NOT DAYS)
- Eliminates Steel and Concrete Reinforcing
- Safer on Workers
  - No Workers Walking Lintels with Heavy Hoses
  - No Rebar Above the Slab with "OSHA SAFE" Caps
- Environmentally Friendly (Eliminates Concrete Washout for Lintels)
- All Components Can be Inspected after Framing
- Eliminates Lintel Inspection
- Eliminates Coordination and Installation of Truss Anchors
- Uninterrupted Load Path from the Uppermost Top Plate to the Foundation
- Wood Top Plates Allows for Easier Connection of Trusses on Top of Wall
- Lighter Structure—May Allow Reduced Footing Sizes

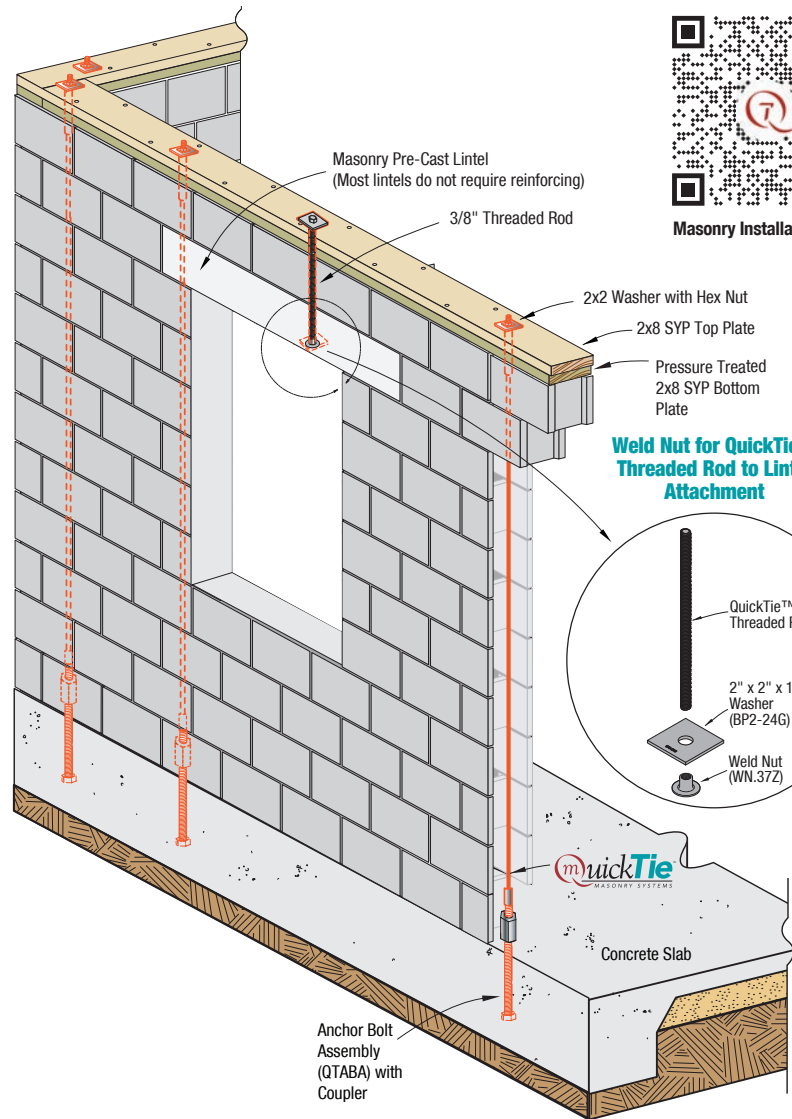

**Weld Nut for QuickTie™/ Threaded Rod to Lintel Attachment**

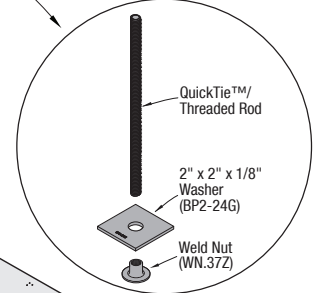

**QuickTie™ Masonry - PVC Sleeve**

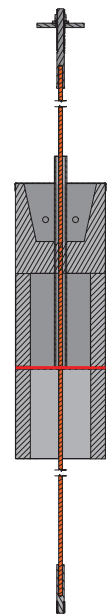
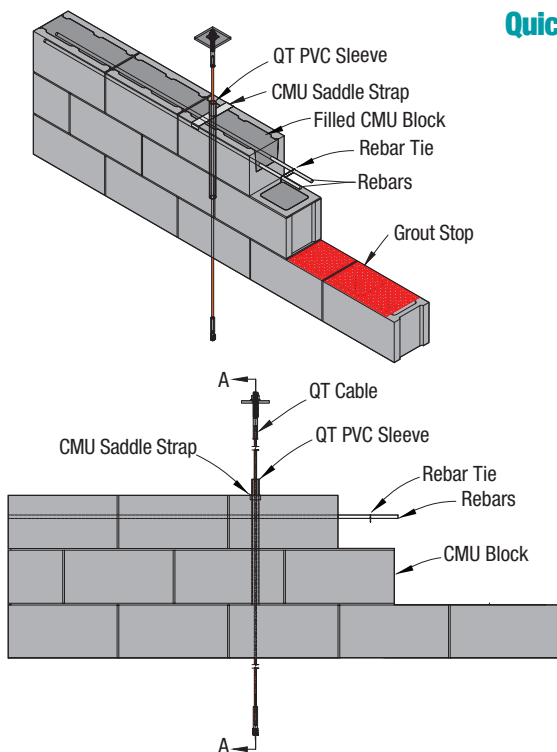

SECTION A-A

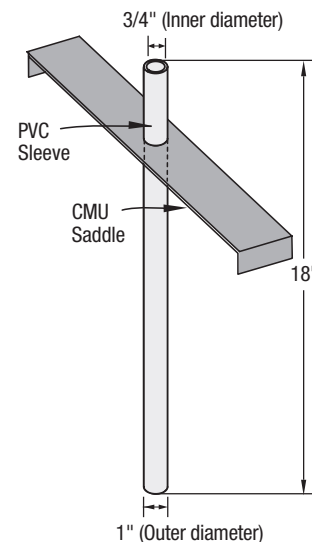

**QTMS**

# Hurricane Anchors and Twist Straps

## HA4, HA6, HA8, HA10, QGC, LTS, MTS & HTS

### PRODUCT FEATURES:

Hurricane Anchors/Clips (HA4, HA6, HA8 & HA10) add increased resistance to wind uplift. HA's reduces toe-nailing, utilizing correctly located nail holes for fast, easy and strong attachment of rafters and trusses to plates and studs.

The QuickTie™ Girder Connectors (QGC & QGCW) are used for girder truss connections where uplift load requirements are high.

The Twist Straps - Light (LTS), Medium (MTS) and Heavy (HTS) - are used to resist wind uplift and manufactured in lengths of 16", 20", 24" and 28". The straps have an offset shape to allow for twisting and bending. Each strap is 1-1/4" wide with nail holes (staggered across the width) punched at 1" along its length.

### MATERIAL:

HA4, HA6, HA8 & HA10 - 18 ga

QGC - 12 ga

LTS - 18 ga

MTS - 16 ga

HTS - 14 ga

### COATING:

Galvanized (G185)



### INSTALLATION:

- Use all specified fasteners in schedule to achieve the tabulated values.

### CODE COMPLIANCE:

TER 0910-01; FL 3557

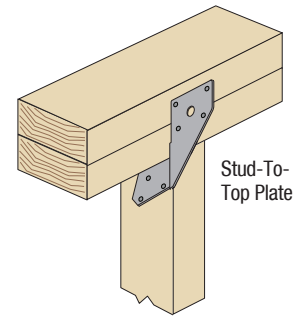
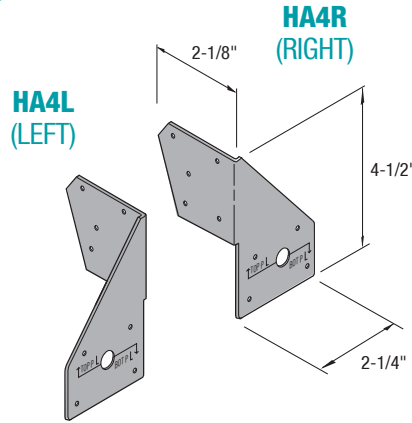

Stud-To-Top Plate

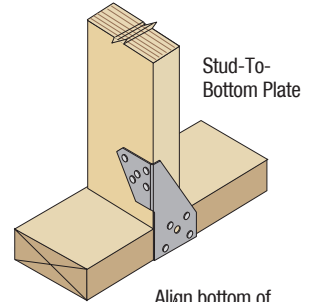

Stud-To-Bottom Plate

Align bottom of connector to bottom of wood plate.

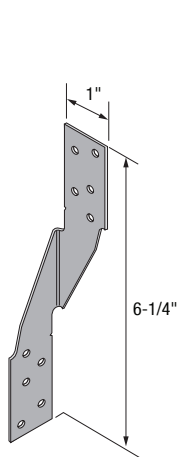
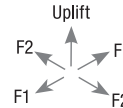
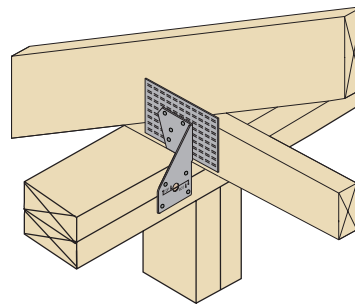

HA6

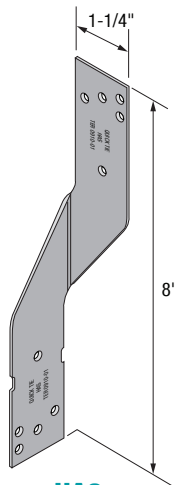

HA8

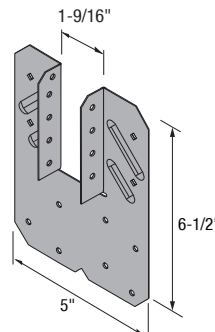

HA10

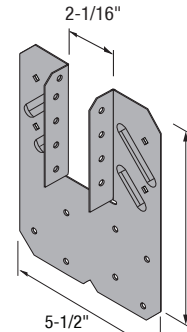

HA10R

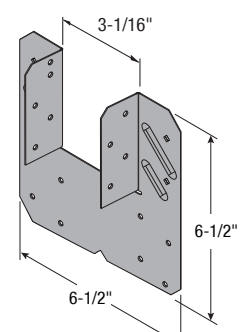

HA10-2

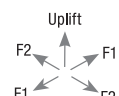
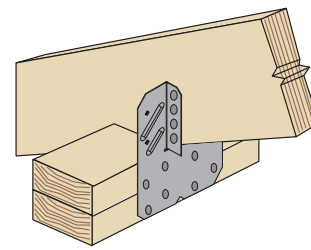
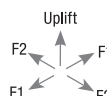
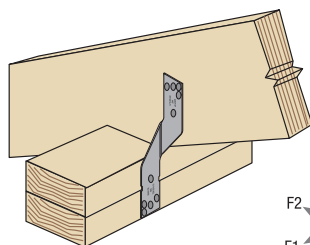
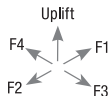
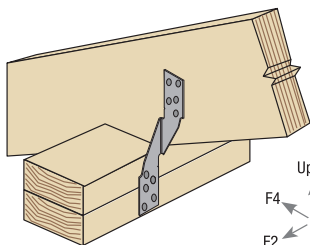

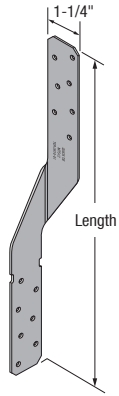

**LTS, MTS & HTS**

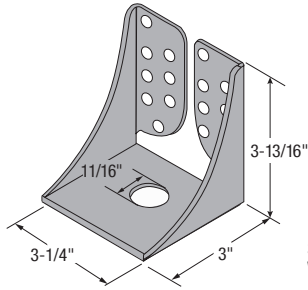

**QGC for QT Cables**  
(Part includes structural wood screws)

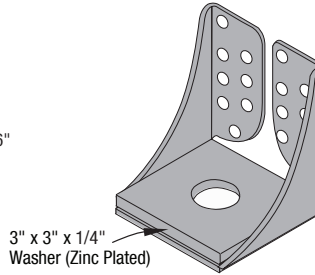

**QGCW for Threaded Rods**  
(Part includes washer and structural wood screws)

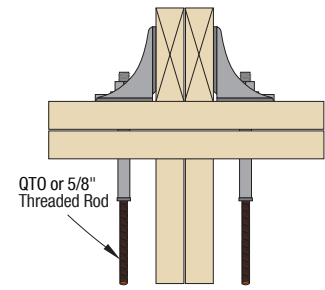

QGC (back-to-back)  
for 2-ply truss/rafter

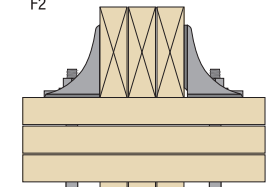
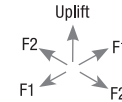

QGC (back-to-back)  
for 3-ply truss/rafter

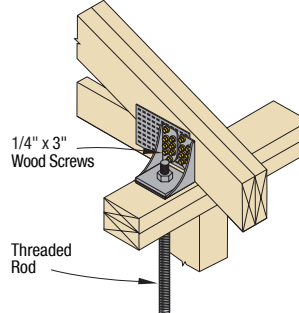
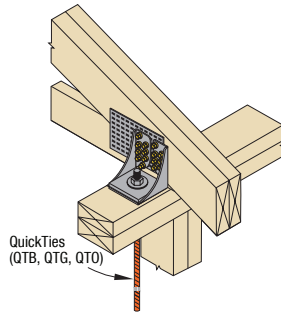
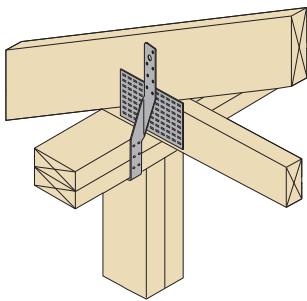

**ALLOWABLE LOADS FOR HA4, HA6, HA8, HA10 & QGC<sup>1,2</sup> AND MTS & HTS (LB)<sup>3,4,5</sup>**

	Part No.	Type	Fasteners		Southern Pine (SG = 0.55)				Douglas Fir-Larch (SG = 0.50)				Spruce-Pine-Fir (SG = 0.42)			
			Rafter/Truss	Plates	Uplift	1.6	F1	F2	Uplift	1.6	F1	F2	Uplift	1.6	F1	F2
HA	HA4	8d x 1-1/2 (0.131 x 1.5")	5	4	-	662	180	120	-	599	158	120	-	514	135	106
		10d x 1-1/2 (0.148 x 1.5")			-	662	180	120	-	599	158	120	-	514	135	106
	HA6	8d x 1-1/2 (0.131 x 1.5")	5	5	535	705	145	140	495	655	125	125	425	575	80	100
		10d x 1-1/2 (0.148 x 1.5")			535	705	145	140	495	655	125	125	425	575	80	100
HA8	5	5	8d x 1-1/2 (0.131 x 1.5")	-	600	61	61	-	600	61	61	-	485	61	61	
			10d x 1-1/2 (0.148 x 1.5")	-	815	94	94	-	705	69	69	-	540	69	69	
HA10 HA10R HA10-2	9	8	10d x 1-1/2 (0.148 x 1.5")	1,005	1,140	560	335	930	1,055	515	310	800	910	335	220	
			10d Common (0.148 x 3")	1,005	1,350	560	330	930	1,245	515	280	800	1,075	335	230	
LTS	LTS12-3Z LTS16-3Z LTS18-3Z LTS20-3Z	10d x 1-1/2 (0.148 x 1.5") 10d Common (0.148 x 3")	12 <sup>6</sup>	6 <sup>7</sup>	755	875	-	-	695	810	-	-	600	700	-	-
MTS	MTS12-3Z MTS16-3Z MTS20-3Z MTS24-3Z	10d x 1-1/2 (0.148 x 1.5") 10d Common (0.148 x 3")	14 <sup>6</sup>	7 <sup>7</sup>	895	1,085	-	-	825	1,000	-	-	715	865	-	-
HTS	HTS16-3Z HTS20-3Z HTS24-3Z HTS28-3Z	10d x 1-1/2 (0.148 x 1.5") 10d Common (0.148 x 3")	22 <sup>6</sup>	11 <sup>7</sup>	1,445	1,665	-	-	1,340	1,540	-	-	1,160	1,330	-	-
GC	QGC	1/4" Wood Screw (included)	16	(1) QTB	1,910	1,910	-	-	1,910	1,910	-	-	1,910	1,910	-	-
				(1) QTG	3,180	3,180	-	-	3,180	3,180	-	-	3,180	3,180	-	-
				(1) QTO	4,350	4,455	2,040	935	4,015	4,455	1,910	885	3,465	4,390	1,570	765
QGCW	1/4" Wood Screw (included)	16	(1) 5/8" Threaded Rod	4,350	5,445	1,235	770	4,015	5,085	1,185	705	3,465	4,455	1,090	550	
QGC/QGCW	1/4" Wood Screw (included)	32	(2) QTO or (2) 5/8" Threaded Rods	8,715	8,715	-	-	8,450	8,450	-	-	7,295	7,295	-	-	

**NOTES:**

- Hurricane Anchors/Clips may be installed on both sides of the framing member for twice the load. QGC/QCW may be installed on both sides (back-to-back) of the 3-ply rafter/truss for twice the load.
- The tabulated loads are valid for clips installed on the inside or the outside of the wall. However, to maintain a continuous load path for uplift, connections in close proximity to one another, such as truss-to-plate and plate-to-stud, clips should be installed on the same side of the wall.
- Straps do not have to be wrapped over the truss or rafter to achieve the loads shown.
- Straps may be installed on either side of the framing member.
- The number of fasteners shown in the table is the minimum required to achieve the loads shown.
- Minimum nails required per strap.
- Minimum nails at each end of the strap.

# Stud Plate Ties

## STUD PLATE TIES (RSPT)

### PRODUCT FEATURES:

RSPTs (Stud Plate Ties) securely connect studs to top and bottom plates, helping protect structures against wind uplift. They're easy to use and work with both single or double studs and plates.

### MATERIAL:

RSPT4 – 20 ga  
RSPT6M, RSPT6, RSPT6-2 – 18 ga

### COATING:

Galvanized (G185)

### INSTALLATION:

- Use all specified fasteners in schedule to achieve values indicated.
- Fill all round holes for sill plate and all round and triangle holes for top plate installations.

### CODE COMPLIANCE:

TER 0910-01; FL 3557

**New**

**3Z**  
ZINC FINISH

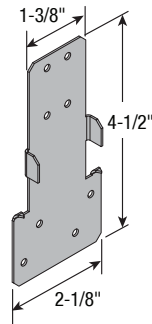

**RSPT4**

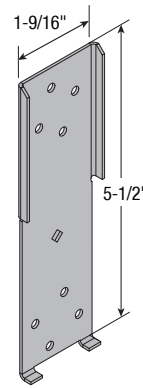

**RSPT6M**

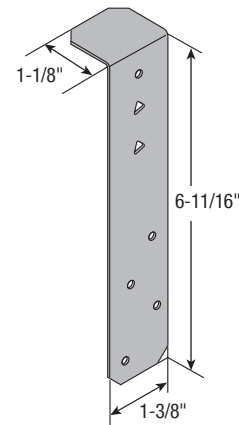

**RSPT6**

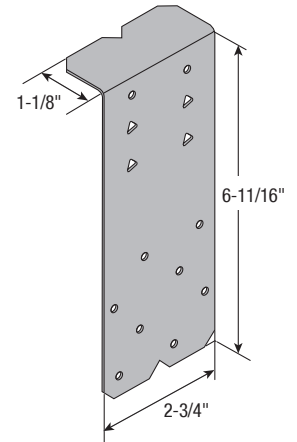

**RSPT6-2**

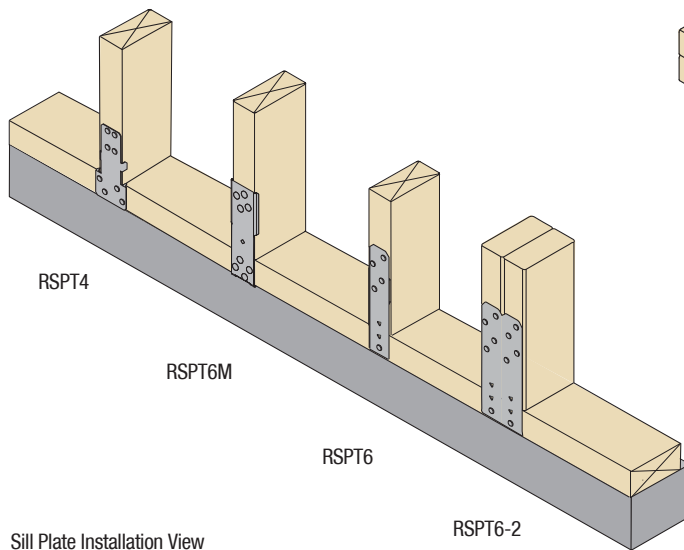

Sill Plate Installation View

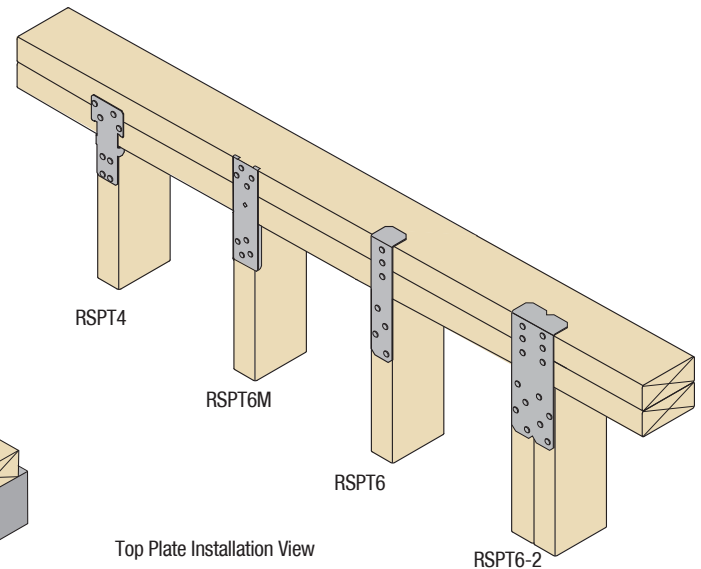

Top Plate Installation View

## ALLOWABLE LOADS FOR STUD PLATE TIES (LB)<sup>1</sup>

Part No.	Dimensions (in.)		Fasteners						Allowable Uplift ( $C_D = 1.6$ )			
	Width	Height	Stud		Double Top Plate		Single Sill Plate		Double Top Plate		Single Sill Plate	
			Qty	Size	Qty	Size	Qty	Size	SP/DF-L	HF/S-P-F	SP/DF-L	HF/S-P-F
<b>RSPT4<sup>2</sup></b>	2-1/8	4-1/2	4	8d x 1-1/2	4	8d x 1-1/2	4	8d x 1-1/2	515	440	435	375
<b>RSPT6M</b>	1-9/16	5-1/2	4	10d x 1-1/2	4	10d x 1-1/2	4	10d x 1-1/2	755	650	655	565
<b>RSPT6</b>	2-1/8	6-11/16	4	10d x 1-1/2	3	10d x 1-1/2	1	10d x 1-1/2	475	415	470	405
<b>RSPT6-2</b>	2-1/8	6-11/16	8	10d x 1-1/2	6	10d x 1-1/2	2	10d x 1-1/2	945	830	785	675

### NOTES:

1. Allowable loads are provided for a load duration factor ( $C_D$ ) of 1.6, no further increase is allowed.
2. For RSPT4, F1 = 410 lb (SP/DF-L) & 350 lb (HF/SPF) and F2 = 350 lb (SP/DF-L) & 210 lb (HF/SPF). Evaluated with (3) 0.131" x 3" nails at every stud-to-plate connection.

## STUD PLATE TIES (SPT-3Z & SPTH-3Z)

**PRODUCT FEATURES:**

The SPT-3Z and SPTH-3Z series are 1-1/4" wide straps used to connect a stud to the top or sill plate and resist uplift forces. Each strap has a horizontal section that sits on the wall's top plates and two bent vertical legs that are nailed to the narrow face of the stud.

**MATERIAL:**

SPT-3Z Series - 20 ga  
SPTH-3Z Series - 18 ga

**COATING:**

Galvanized (G185)

**INSTALLATION:**

- Use all specified fasteners in schedule to achieve values indicated.

**CODE COMPLIANCE:**

Call QuickTie for code approval information

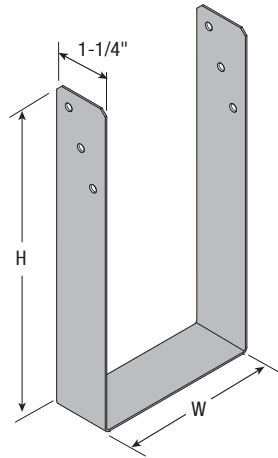

SPT-3Z

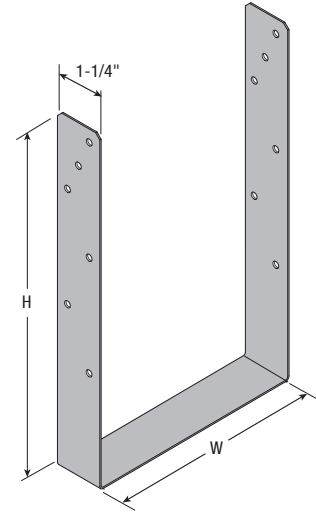

SPTH-3Z

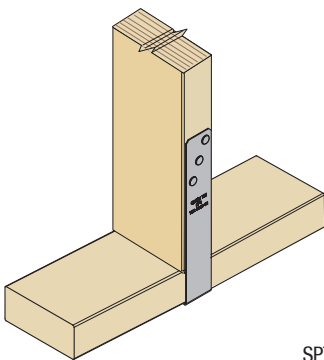

SPT Series to Bottom Plate and Top Plates

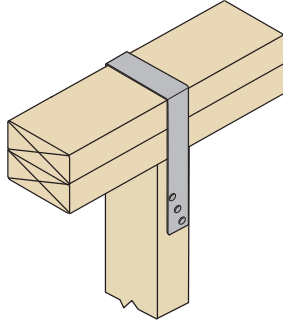

SPTH Series to Bottom Plate and Top Plates

## ALLOWABLE LOADS (LB)

Part No.	Dimensions (in.)		Stud Size	Plate Width	Min. Stud Fasteners		Uplift (C <sub>D</sub> = 1.6)	
	Width, W	Height, H			Qty	Size	DF/SP	SPF/HF
							C <sub>D</sub> = 1.6	C <sub>D</sub> = 1.6
SPT4-3Z	3-9/16	7-1/4	2x	4x	6	10d x 1-1/2	1,105	950
SPT6-3Z	5-9/16	7-3/4		6x				
SPT8-3Z	7-5/16	8-5/16		8x				
SPTH4-3Z	3-9/16	8-3/4	2x	4x	10	10d x 1-1/2	1,840	1,585
SPTH6-3Z	5-9/16	9-1/4		6x				
SPTH8-3Z	7-9/16	8-3/8		8x				

**NOTES:**

1. Allowable loads are provided for load duration factor (C<sub>D</sub>) of 1.6. No further increase is permitted.

# Hurricane Gusset Angles

## HGA & HGAM

### PRODUCT FEATURES:

Hurricane Gusset Angles (HGA/HGAM) are 90-degree framing angles used to connect truss/rafter joists to the top plate of wood framing walls or to the top of concrete filled CMU walls. The HGAKT and HGAMKT includes HGA framing angle and wood screws for wood framing applications and HGA framing angle, wood screws and concrete screws for concrete/CMU applications, respectively.

### MATERIAL:

HGA - 14 ga

### COATING:

Galvanized (G185)



### INSTALLATION:

- Use all specified fasteners in schedule to achieve values indicated.

### CODE COMPLIANCE:

TER 0910-01; FL 3557

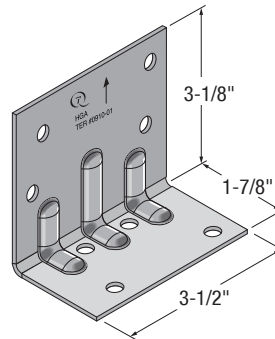

**HGA/HGAM**

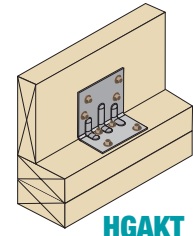
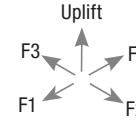

**HGAKT**

(Part includes structural wood screws)

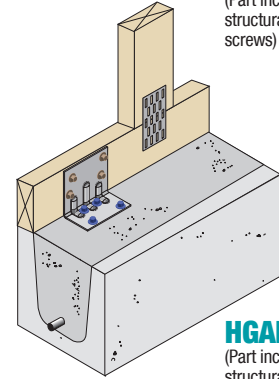

**HGAMKT**

(Part includes structural wood screws and concrete screws)

Part No.	Description	Carton Qty
HGAKT	HGA, 1/4" x 1-1/2" Wood Screws & 1/4 x 3" Wood Screws	10
HGAMKT	HGA, 1/4" x 1-1/2" Wood Screws & 1/4 x 2-1/4" Concrete Screws	10

## ALLOWABLE LOADS FOR HGA & HGAM (LB)

Part No.	Fasteners <sup>4,5,6</sup>				Allowable Loads (lb) <sup>1,2,3</sup>							
	To Rafter/Truss		To Top Plate or Concrete		Douglas Fir-Larch (0.50)				Spruce-Pine-Fir (0.42)			
	Type	Quantity	Type	Quantity	Uplift	F1	F2	F3	Uplift	F1	F2	F3
HGA	SWH15 Wood Screw (1/4" x 1-1/2")	4	SWH3 Wood Screw (1/4" x 3")	4	1,085	1,085	895	1,150	740	695	420	825
HGAM	SWH15 Wood Screw (1/4" x 1-1/2")	4	Concrete Screw (1/4" x 2-1/4")	4	815	1,005	955	1,005	815	805	505	825

### NOTES:

1. Loading in the F1 direction indicates shear forces parallel to the plane of the wall.
2. Loading in the F2 direction indicates shear forces perpendicular to the plane of the wall, acting towards the gusset angle.
3. Loading in the F3 direction indicates shear forces perpendicular to the plane of the wall, acting away from the gusset angle.
4. Minimum fastener penetration must be equal to the screw length less the thickness of the metal side plate.
5. Refer to page 71 for structural wood screw SWH15 (1/4" x 1-1/2") and SWH3 (1/4" x 3") details.
6. Concrete Screw: Minimum Allowable Tension (T) and Shear (S) Capacities When Installed in Concrete, T = 204 lb and S = 219 lb, Min. Edge Distance = 2", Min. Spacing = 1", Min End Distance = 2.65", Min. Embedment = 1 1/2", Min. Concrete Compression Strength, f<sub>c</sub> = 2,500 psi, Load combination 1.2D+1.6L with D = 0.3, L = 0.7 and α = 1.48.

## HDTT (DECK TENSION TIE)

### PRODUCT FEATURES:

HDTT's are deck tension ties designed to satisfy the minimum requirements for deck construction per IRC 507. The part includes bend washer and wood screws.

### MATERIAL:

HDTT - 14 ga

### COATING:

Galvanized (G185)



### INSTALLATION:

- Use all specified fasteners in schedule to achieve values indicated.

### CODE COMPLIANCE:

TER 0910-01; FL 3557

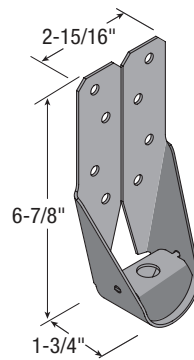

**HDTT**

(Part includes bend washer and structural wood screws)

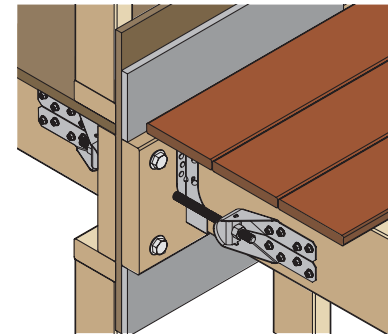

## ALLOWABLE LOADS FOR DECK TENSION TIE (LB)<sup>1,2,3</sup>

Part No.	Steel Gauge	Dimensions (in.)						Fasteners				Tension (lb)			
		Height	Width	Depth	Stud to Anchor CL (in.)	Bottom Plate to Top of Washer (in.)	Min. Wood Member Size (in.)	Nails/Screws/Bolts		Anchor Bolt <sup>c</sup>		SP / DF-L (SG = 0.50)		S-P-F (SG = 0.42)	
								Type	Qty	Size	Qty	C <sub>D</sub> = 1.6	Δ(1.6)	C <sub>D</sub> = 1.6	Δ(1.6)
HDTT	14 ga	6-7/8	3-1/4	1-3/4	1	1-3/16	1-1/2 x 3-1/2	SWH15	8	1/2	1	2,430	0.347	2,105	-

### NOTES:

1. Anchor bolt installation into any substrates should be designed to resist the allowable uplift loads.
2. Allowable loads based on connector attached to 2x4 from 1" above the base (i.e. no resistance from prying action).
3. Refer to page 71 for structural wood screw SWH15 (1/4"x1-1/2") details.

# Shear Clips/Flats and Plywood Clips



## SC34, SC35 & SC35F

**PRODUCT FEATURES:**

Shear Clips (SC34 & SC35) and Flat Shear Clips (SC35F) are multi-purpose framing angles and flat connectors for connecting studs, plates, headers, joists, etc.

**MATERIAL:**

SC34, SC35 & SC35F - 18 ga

**COATING:**

Galvanized (G185)



**INSTALLATION:**

- Use all specified fasteners in schedule to achieve values indicated.

**CODE COMPLIANCE:**

TER 0910-01; FL 3557

Part No.	Carton Qty
SC34	100
SC35	100
SC35F	200

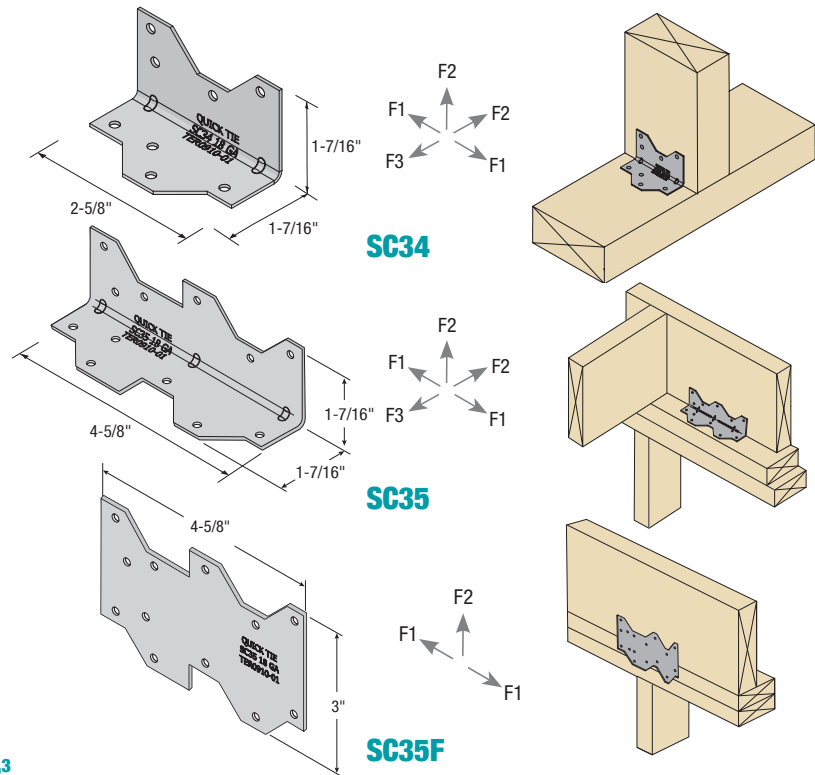

## ALLOWABLE LOADS FOR SC34, SC35 & SC35F<sup>1,2,3</sup>

Part No.	Species	Fasteners		Allowable Loads (lb)					
				F1		F2		F3	
		Size	Total	1.00	1.60	1.00	1.60	1.00	1.60
SC34	Southern Pine	8d x 1-1/2"	8	425	685	425	685	215	325
	Douglas Fir-Larch	8d x 1-1/2"	8	395	630	395	630	170	255
	Spruce-Pine-Fir	8d x 1-1/2"	8	340	545	340	540	110	175
SC35	Southern Pine	10d x 1-1/2"	12	755	840	295	295	755	1,075
		10d x 3"	12	770	940	260	260	770	1,015
	Douglas Fir-Larch	10d x 1-1/2"	12	695	765	265	265	695	975
		10d x 3"	12	710	840	235	235	710	905
	Spruce-Pine-Fir	10d x 1-1/2"	12	595	650	200	230	595	830
		10d x 3"	12	605	720	200	200	605	775
SC35F	Southern Pine	10d x 1-1/2"	12	755	775	500	500	-	-
		10d x 3"	12	735	735	550	550	-	-
	Douglas Fir-Larch	10d x 1-1/2"	12	655	655	430	430	-	-
		10d x 3"	12	615	615	470	470	-	-
	Spruce-Pine-Fir	10d x 1-1/2"	12	560	560	370	370	-	-
		10d x 3"	12	525	525	400	400	-	-

**NOTES:**

1. The tabulated loads are per framing angle and flat connector.
2. SC34 and SC35 - Connectors are required on both sides of the joist/stud to achieve the F3 loads in both directions.
3. SC34 and SC35 - When installed directly across from each other on both sides of the joist/stud, the thickness of the joist/stud should be twice the length of the fastener.

## PC SERIES

**PRODUCT FEATURES:**

Plywood clips are used to support sheathing edges between rafters/trusses.

**MATERIAL:** 20 ga

**COATING:**

Galvanized

**INSTALLATION:**

- Install same size clip as panel thickness centered between rafter/truss.

Part No.	Description	Carton Qty
PC38	3/8" Panel Thickness	250
PC716	7/16" Panel Thickness	250
PC1532	15/32" Panel Thickness	250
PC12	1/2" Panel Thickness	250
PC1932	19/32" Panel Thickness	250
PC58	5/8" Panel Thickness	250
PC34	3/4" Panel Thickness	250

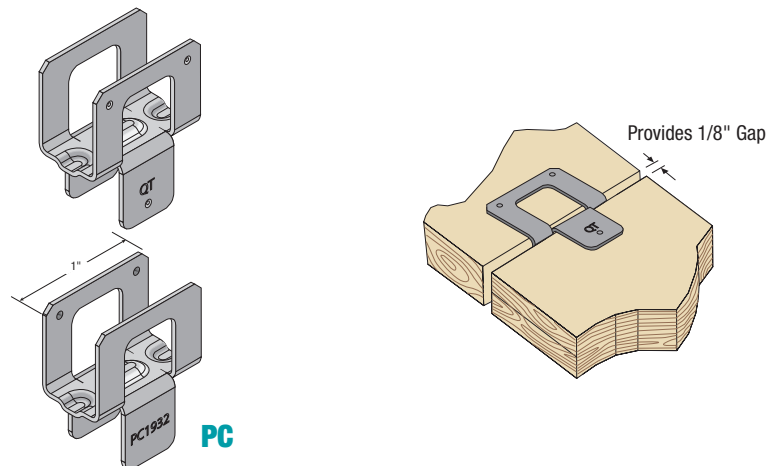

# Flat Straps

## LS & MS SERIES

### PRODUCT FEATURES:

The Light Strap (LS) and Medium Strap (MS) are used to resist wind uplift and are manufactured in lengths varying from 9-5/8" to 48-5/8". Each strap is 1-1/4" wide with nail holes punched at intervals of 1-1/2" along its length. The nail holes are staggered across the width of the strap to prevent wood splitting.

### MATERIAL:

LS Series - 20 ga

MS Series - 16 ga

### COATING:

Galvanized (G185)

### INSTALLATION:

- Use all specified fasteners in schedule to achieve values indicated.
- May be installed on each side of member for twice the loads when the member thickness is greater than 2-1/2".

### CODE COMPLIANCE:

TER 0910-01; FL 3557

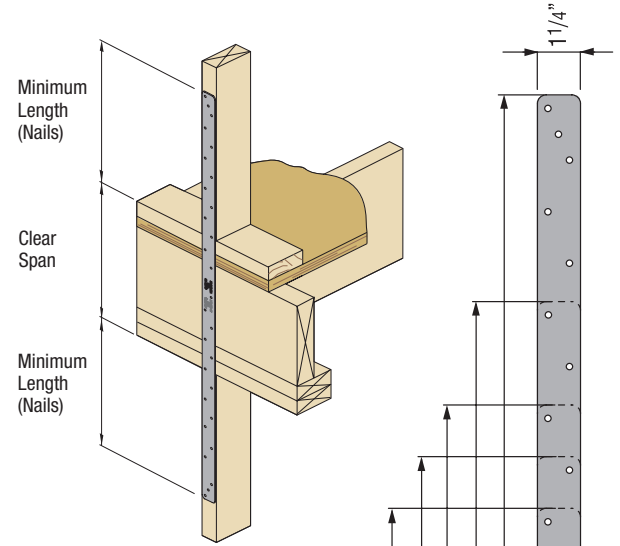

## ALLOWABLE TENSION LOADS FOR LS & MS SERIES STRAPS (LB)<sup>1,2</sup>

	Part No.	Fasteners		Southern Pine (SG=0.55)		Douglas Fir - Larch (SG=0.50)		Spruce - Pine - Fir (SG=0.42)	
		Size	No. of Nails Each End of Strap	Load Duration Factor <sup>2</sup>					
				1.00	1.60	1.00	1.60	1.00	1.60
LS	LS9	8d (0.131 x 2.5")	4	415	665	385	615	330	525
	LS12		5	520	830	480	770	410	655
	LS18		7	730	1,165	670	1,075	575	920
	LS21		8	830	1,295	770	1,229	655	1,050
	LS24		9	935	1,295	865	1,295	740	1,180
	LS9	10d x 1 1/2 (0.148 x 1.5")	4	500	800	460	735	390	625
	LS12		5	625	1,000	575	920	490	785
	LS18		7	875	1,295	805	1,290	685	1,100
	LS21		8	1,000	1,295	920	1,295	785	1,255
	LS24		9	1,125	1,295	1,035	1,295	880	1,295
	LS9	10d (0.148 x 3")	4	505	805	465	740	395	635
	LS12		5	630	1,010	580	930	495	790
LS18	7		880	1,295	810	1,295	695	1,110	
LS21	8		1,010	1,295	930	1,295	790	1,265	
LS24	9		1,135	1,295	1,045	1,295	890	1,295	
MS	MS12*	8d (0.131 x 2.5")	5	545	870	505	805	435	695
	MS24		9	980	1,570	910	1,455	785	1,255
	MS27		10	1,090	1,745	1,010	1,615	870	1,390
	MS30		11	1,200	1,920	1,110	1,780	955	1,530
	MS36		13	1,415	2,120	1,315	2,100	1,130	1,810
	MS48		14	1,525	2,120	1,415	2,120	1,220	1,950
	MS12*	10d x 1 1/2 (0.148 x 1.5")	5	600	960	600	960	525	840
	MS24		9	1,150	1,845	1,060	1,700	910	1,455
	MS27		10	1,280	2,050	1,180	1,890	1,010	1,615
	MS30		11	1,410	2,120	1,300	2,075	1,110	1,780
	MS36		13	1,665	2,120	1,535	2,120	1,315	2,100
	MS48		14	1,790	2,120	1,650	2,120	1,415	2,120
	MS12*	10d (0.148 x 3")	5	600	960	600	960	525	840
	MS24		9	1,180	1,885	1,090	1,740	935	1,500
	MS27		10	1,310	2,095	1,210	1,935	1,040	1,665
	MS30		11	1,440	2,120	1,330	2,120	1,145	1,830
	MS36		13	1,705	2,120	1,575	2,120	1,350	2,120
	MS48		14	1,835	2,120	1,695	2,120	1,455	2,120

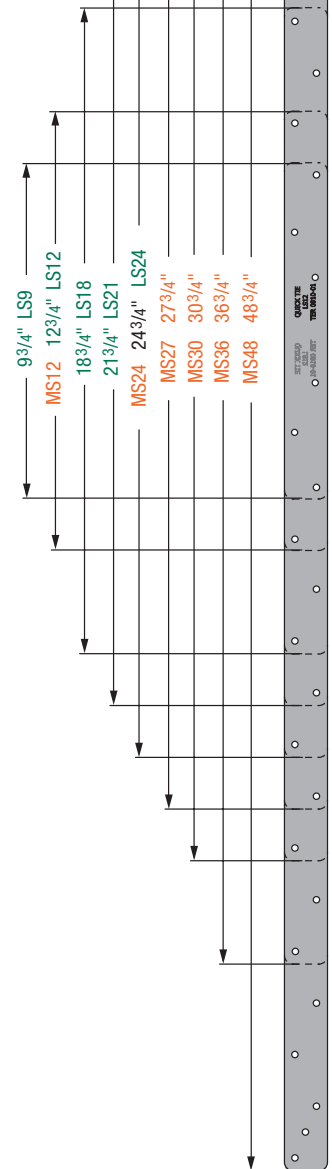

### NOTES:

1. Allowable tension loads apply for uplift when the straps are installed vertically.

2. Allowable tension loads for load durations of two months (i.e., 115%) and seven days (i.e., 125%) may be obtained by multiplying the corresponding allowable tension load in the load duration factor column marked "1.0" by 1.15 or 1.25 respectively, with a maximum of 1,295 lb (LS Series) and 2,118 lb (MS Series).

\*Call QT for code approval information.

## CS & CMST SERIES

### PRODUCT FEATURES:

Coil strap has pre-drilled nail holes, which allows the installer to cut to any length as required for a wide range of wood connections.

### MATERIAL:

CS Series (1-1/4" width):

- CS20-250 - 20 ga, 250 ft
- CS18-200 - 18 ga, 200 ft
- CS16-150 - 16 ga, 150 ft
- CS14-100 - 14 ga, 100 ft

CMST Series (3" width):

- CMST16-54 - 16 ga, 54 ft
- CMST14-52.5 - 14 ga, 52-1/2 ft
- CMST14-12 - 14 ga, 12 ft
- CMST12-40 - 12 ga, 40 ft
- CMSTC84 - 12 ga, 7 ft

### COATING:

Galvanized (G185)



### INSTALLATION:

- Use all specified fasteners in schedule to achieve values indicated.

### CODE COMPLIANCE:

TER 0910-01; FL 3557

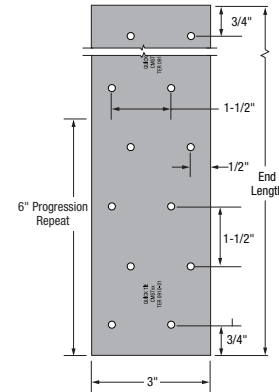
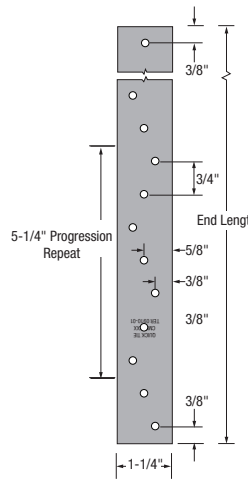

CS

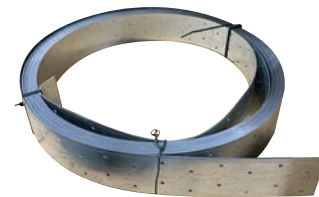

CMST

## ALLOWABLE TENSION LOADS FOR CS20-250 STRAP (LB)<sup>1,2</sup>

	Fasteners		Minimum Required End Length (in.)	Southern Pine (SG = 0.55)		Douglas Fir - Larch (SG = 0.50)		Spruce - Pine - Fir (SG = 0.42)	
				Load Duration Factor					
	Size	No. Each End of Strap		1.0	1.60	1.0	1.60	1.0	1.60
CS20-250	8d x 1-1/2 (0.131 x 1.5") & 8d Common (0.131 x 2.5")	4	3	417	668	385	615	331	530
		6	4 1/2	626	1,001	577	923	497	794
		8	6	834	1,335	769	1,231	662	1,059
		10	7 1/2	1,043	1,343	962	1,343	828	1,324
		11	8 1/4	1,147	1,343	1,058	1,343	910	1,343
		12	9	1,252	1,343	1,154	1,343	993	1,343
		13	9 3/4	1,343	1,343	1,250	1,343	1,076	1,343
		14	10 1/2	1,343	1,343	1,343	1,343	1,159	1,343
	15	11 1/4	1,343	1,343	1,343	1,343	1,241	1,343	
	16	12	1,343	1,343	1,343	1,343	1,324	1,343	
	17	12 3/4	1,343	1,343	1,343	1,343	1,343	1,343	
	10d x 1-1/2 (0.148 x 1.5") & 10d Common (0.148 x 3")	4	3	504	806	464	743	399	639
		6	4 1/2	755	1,209	696	870	599	958
		8	6	1,007	1,343	928	1,114	799	1,278
9		6 3/4	1,133	1,343	1,044	1,343	898	1,343	
10		7 1/2	1,259	1,343	1,160	1,343	998	1,343	
11		8 1/4	1,343	1,343	1,277	1,343	1,098	1,343	
12		9	1,343	1,343	1,343	1,343	1,198	1,343	
13	9 3/4	1,343	1,343	1,343	1,343	1,298	1,343		
CS18-200	8d x 1-1/2 (0.131 x 1.5") & 8d Common (0.131 x 2.5")	4	3	426	682	393	629	339	543
		6	4-1/2	639	1,022	590	944	509	814
		8	6	852	1,363	787	1,258	678	1,085
		10	7-1/2	1,065	1,704	983	1,573	848	1,356
		12	9	1,278	1,777	1,180	1,777	1,017	1,628
		14	10-1/2	1,491	1,777	1,376	1,777	1,187	1,777
		16	12	1,704	1,777	1,573	1,777	1,356	1,777
		17	12-3/4	1,777	1,777	1,671	1,777	1,441	1,777
		18	13-1/2	1,777	1,777	1,770	1,777	1,526	1,777
		19	14-1/4	1,777	1,777	1,777	1,777	1,611	1,777
		20	15	1,777	1,777	1,777	1,777	1,695	1,777
21	15-3/4	1,777	1,777	1,777	1,777	1,777	1,777		

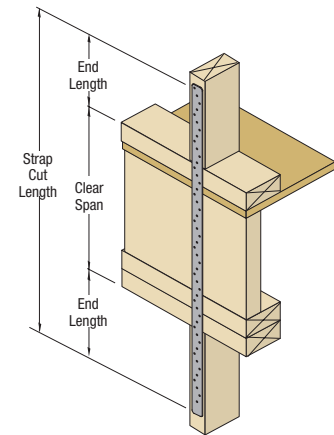

### NOTES:

1. Allowable tension loads apply for uplift when the straps are installed vertically.
2. The total strap cut length is equal to the Clear Span + 2 x End Length.

Continued on next page.

# Coil Strapping

## ALLOWABLE TENSION LOADS FOR CS18-200, CS16-150, CS14-100 & CMST16-54 COIL STRAPS (LB)<sup>1,2</sup>

	Fasteners		Minimum Required End Length (in.)	Southern Pine (SG = 0.55)		Douglas Fir - Larch (SG = 0.50)		Spruce - Pine - Fir (SG = 0.42)			
	Size	No. Each End of Strap		Load Duration Factor							
				1.0	1.60	1.0	1.60	1.0	1.60		
CS18-200	10d x 1-1/2 (0.148 x 1.5") & 10d Common (0.148 x 3")	4	3	512	820	473	757	408	652		
		6	4-1/2	769	1,230	709	1,135	611	978		
		8	6	1,025	1,640	946	1,513	815	1,304		
		10	7-1/2	1,281	1,777	1,182	1,777	1,019	1,630		
		11	8-1/4	1,409	1,777	1,300	1,777	1,121	1,777		
		12	9	1,537	1,777	1,419	1,777	1,223	1,777		
		13	9-3/4	1,665	1,777	1,537	1,777	1,324	1,777		
		14	10-1/2	1,777	1,777	1,655	1,777	1,426	1,777		
		15	11-1/4	1,777	1,777	1,773	1,777	1,528	1,777		
		16	12	1,777	1,777	1,777	1,777	1,630	1,777		
		17	12-3/4	1,777	1,777	1,777	1,777	1,732	1,777		
		18	13-1/2	1,777	1,777	1,777	1,777	1,777	1,777		
		CS16-150	8d x 1-1/2 (0.131 x 1.5") & 8d Common (0.131 x 2.5")	4	3	438	701	405	648	350	560
				6	4-1/2	658	1,052	608	972	525	840
				8	6	877	1,403	810	1,296	700	1,120
				10	7-1/2	1,096	1,754	1,013	1,621	875	1,400
				12	9	1,315	2,104	1,215	1,945	1,050	1,679
				14	10-1/2	1,534	2,206	1,418	2,026	1,225	1,959
16	12			1,754	2,206	1,621	2,206	1,400	2,206		
18	13-1/2			1,973	2,206	1,823	2,206	1,575	2,206		
20	15			2,192	2,206	2,026	2,206	1,749	2,206		
21	15-3/4			2,206	2,206	2,127	2,206	1,837	2,206		
22	16-1/2		2,206	2,206	2,206	2,206	1,924	2,206			
24	18		2,206	2,206	2,206	2,206	2,099	2,206			
26	19-1/2		2,206	2,206	2,206	2,206	2,206	2,206			
10d x 1 1/2 (0.148 x 1.5") & 10d Common (0.148 x 3")	4		3	525	840	485	776	419	670		
	6		4-1/2	788	1,261	728	1,164	628	1,005		
	8		6	1,050	1,681	970	1,553	838	1,340		
	10		7-1/2	1,313	2,101	1,213	1,941	1,047	1,675		
	12		9	1,576	2,206	1,456	2,206	1,256	2,010		
	14	10-1/2	1,838	2,206	1,698	2,206	1,466	2,206			
	16	12	2,101	2,206	1,941	2,206	1,675	2,206			
	18	13-1/2	2,206	2,206	2,183	2,206	1,885	2,206			
	20	15	2,206	2,206	2,206	2,206	2,094	2,206			
	22	16-1/2	2,206	2,206	2,206	2,206	2,206	2,206			
CS14-100	8d x 1-1/2 (0.131 x 1.5") & 8d Common (0.131 x 2.5")	4	3	457	732	423	677	366	586		
		6	4-1/2	686	1,098	635	1,015	549	878		
		8	6	915	1,464	846	1,354	732	1,171		
		10	7-1/2	1,143	1,829	1,058	1,692	915	1,464		
		12	9	1,372	2,195	1,269	2,031	1,098	1,757		
		14	10-1/2	1,601	2,561	1,481	2,369	1,281	2,050		
		16	12	1,829	2,718	1,692	2,708	1,464	2,343		
		18	13-1/2	2,058	2,718	1,904	2,718	1,647	2,635		
		20	15	2,287	2,718	2,115	2,718	1,830	2,718		
		22	16-1/2	2,515	2,718	2,327	2,718	2,013	2,718		
		24	18	2,718	2,718	2,539	2,718	2,196	2,718		
		25	18-3/4	2,718	2,718	2,644	2,718	2,288	2,718		
	26	19-1/2	2,718	2,718	2,718	2,718	2,379	2,718			
	27	20-1/4	2,718	2,718	2,718	2,718	2,471	2,718			
	28	21	2,718	2,718	2,718	2,718	2,562	2,718			
	29	21-3/4	2,718	2,718	2,718	2,718	2,654	2,718			
	30	22-1/2	2,718	2,718	2,718	2,718	2,718	2,718			
	10d x 1-1/2 (0.148 x 1.5") & 10d Common	4	3	545	872	504	806	436	697		
6		4-1/2	818	1,308	756	1,210	654	1,046			
8		6	1,090	1,744	1,008	1,613	872	1,395			
10		7-1/2	1,363	2,180	1,260	2,016	1,090	1,743			
12		9	1,635	2,616	1,512	2,419	1,307	2,092			
14		10-1/2	1,908	2,718	1,764	2,718	1,525	2,441			
16		12	2,180	2,718	2,016	2,718	1,743	2,718			
18		13-1/2	2,453	2,718	2,268	2,718	1,961	2,718			
20		15	2,718	2,718	2,520	2,718	2,179	2,718			
21		15-1/2	2,718	2,718	2,646	2,718	2,288	2,718			
22		16-1/2	2,718	2,718	2,718	2,718	2,397	2,718			
23		17-1/4	2,718	2,718	2,718	2,718	2,506	2,718			
CMST16-54	10d Common (0.148 x 3")	6	4-1/2	788	1,261	728	1,164	628	1,005		
		12	9	1,576	2,521	1,456	2,329	1,256	2,010		
		18	13-1/2	2,364	3,782	2,183	3,493	1,885	3,015		
		24	18	3,151	5,042	2,911	4,658	2,513	4,021		
		30	22-1/2	3,939	5,295	3,639	5,295	3,141	5,026		
		36	27	4,727	5,295	4,367	5,295	3,769	5,295		
		42	31-1/2	5,295	5,295	5,095	5,295	4,397	5,295		
		48	36	5,295	5,295	5,295	5,295	5,026	5,295		
		54	40-1/2	5,295	5,295	5,295	5,295	5,295	5,295		

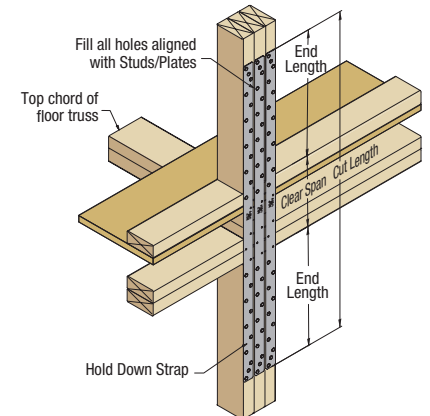
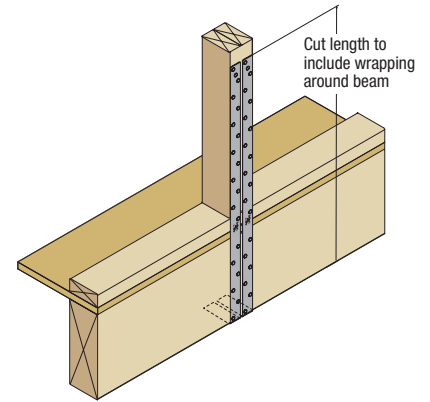
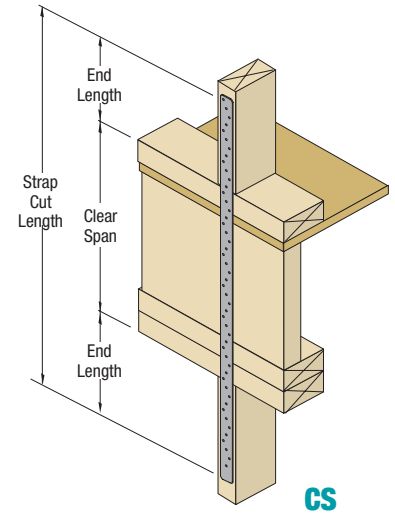

### NOTES:

1. Allowable tension loads apply for uplift when the straps are installed vertically.
2. The total strap cut length is equal to the Clear Span + 2 x End Length.

Continued on next page.

## ALLOWABLE TENSION LOADS FOR CMST16-54, CMST14-52.5, CMST14-12, CMST12-40 & CMST84 COIL STRAPS (LB)<sup>1,2</sup>

	Fasteners		Minimum Required End Length (in.)	Southern Pine (SG = 0.55)		Douglas Fir - Larch (SG = 0.50)		Spruce - Pine - Fir (SG = 0.42)	
	Size	No. Each End of Strap		Load Duration Factor					
				1.0	1.60	1.0	1.60	1.0	1.60
CMST16-54	16d Common (0.162 x 3.5")	6	4-1/2	933	1,493	861	1,378	743	1,189
		12	9	1,866	2,985	1,723	2,757	1,486	2,378
		18	13-1/2	2,799	4,478	2,584	4,135	2,229	3,567
		24	18	3,732	5,295	3,446	5,295	2,972	4,755
		30	22-1/2	4,665	5,295	4,307	5,295	3,715	5,295
		36	27	5,295	5,295	5,169	5,295	4,458	5,295
		42	31-1/2	5,295	5,295	5,295	5,295	5,201	5,295
		48	36	5,295	5,295	5,295	5,295	5,295	5,295
CMST14-52.5 & CMST14-12	10d Common (0.148 x 3")	6	4-1/2	818	1,308	756	1,210	654	1,046
		12	9	1,635	2,616	1,512	2,419	1,307	2,092
		18	13-1/2	2,453	3,925	2,268	3,629	1,961	3,138
		24	18	3,270	5,233	3,024	4,839	2,615	4,184
		30	22-1/2	4,088	6,524	3,780	6,049	3,269	5,230
		36	27	4,906	6,524	4,536	6,524	3,922	6,276
		42	31-1/2	5,723	6,524	5,293	6,524	4,567	6,524
		48	36	6,524	6,524	6,049	6,524	5,230	6,524
		54	40-1/2	6,524	6,524	6,524	6,524	5,884	6,524
		60	45	6,524	6,524	6,524	6,524	6,524	6,524
	16d Common (0.162 x 3.5")	6	4-1/2	962	1,540	889	1,425	768	1,229
		12	9	1,924	3,079	1,779	2,846	1,537	2,459
		18	13-1/2	2,887	4,619	2,668	4,269	2,305	3,688
		24	18	3,849	6,158	3,558	5,692	3,074	4,918
		30	22-1/2	4,811	6,524	4,447	6,524	3,842	6,147
		36	27	5,775	6,524	5,336	6,524	4,611	6,524
		42	31-1/2	6,524	6,524	6,226	6,524	5,379	6,524
		48	36	6,524	6,524	6,524	6,524	6,147	6,524
CMST12-40 & CMST84	10d Common (0.148 x 3")	6	4-1/2	906	1,449	839	1,342	727	1,164
		12	9	1,811	2,898	1,678	2,684	1,455	2,328
		18	13-1/2	2,717	4,347	2,517	4,027	2,182	3,492
		24	18	3,622	5,795	3,356	5,369	2,910	4,656
		30	22-1/2	4,528	7,244	4,194	6,711	3,637	5,820
		36	27	5,433	8,693	5,033	8,053	4,365	6,984
		42	31-1/2	6,339	9,256	5,872	9,256	5,092	8,148
		48	36	7,244	9,256	6,711	9,256	5,820	9,256
		54	40-1/2	8,150	9,256	7,550	9,256	6,547	9,256
		60	45	9,055	9,256	8,390	9,256	7,275	9,256
		66	49-1/2	9,256	9,256	9,228	9,256	8,002	9,256
		72	54	9,256	9,256	9,256	9,256	8,730	9,256
		78	58-1/2	9,256	9,256	9,256	9,256	9,256	9,256
		16d Common (0.162 x 3.5")	6	4-1/2	1,051	1,681	973	1,557	843
	12		9	2,102	3,363	1,946	3,114	1,687	2,698
	18		13-1/2	3,153	5,044	2,919	4,671	2,530	4,048
	24		18	4,204	6,726	3,892	6,228	3,373	5,397
	30		22-1/2	5,254	8,407	4,866	7,785	4,216	6,746
	36		27	6,305	9,256	5,839	9,256	5,060	8,095
	42		31-1/2	7,356	9,256	6,812	9,256	5,903	9,256
	48		36	8,407	9,256	7,785	9,256	6,746	9,256
	54		40-1/2	9,256	9,256	8,758	9,256	7,589	9,256
	60		45	9,256	9,256	9,256	9,256	8,433	9,256
	66	49-1/2	9,256	9,256	9,256	9,256	9,256	9,256	

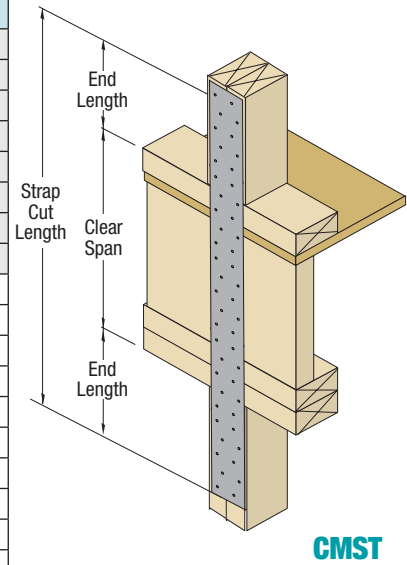

**CMST**

**NOTES:**

1. Allowable tension loads apply for uplift when the straps are installed vertically.
2. The total strap cut length is equal to the Clear Span + 2 x End Length.

# Post Caps

## PCM & EPCM SERIES

### PRODUCT FEATURES:

PCM and EPCM are post caps and end post caps used for post-to-beam connection applications.

### MATERIAL:

PCM/EPCM - 16 ga and 12 ga

### COATING:

Galvanized (G185)



### INSTALLATION:

- Use all specified fasteners in schedule to achieve values indicated.
- EOR's approval is required to substitute 16 ga post caps and end post caps for 12 ga post caps and end post caps.

### CODE COMPLIANCE:

TER 0910-01; FL 3557

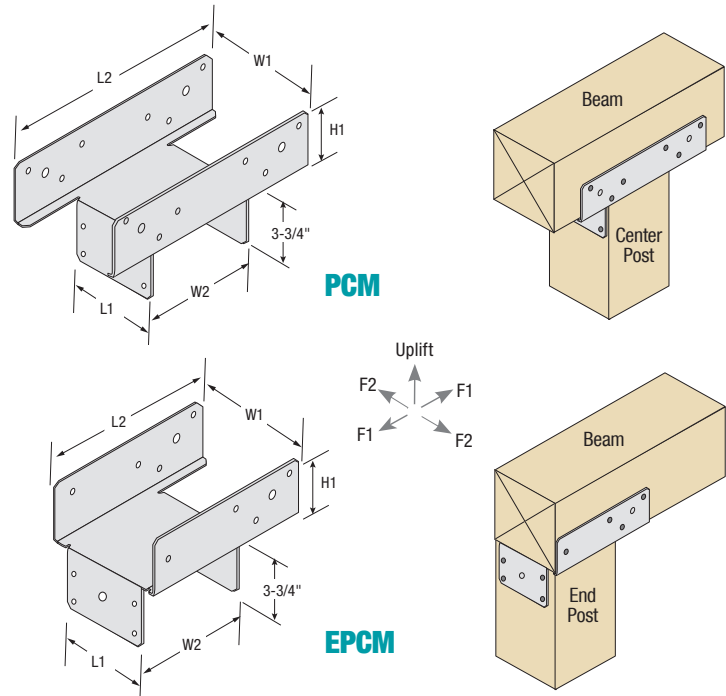

## ALLOWABLE LOADS FOR PCM & EPCM (LB)<sup>1,2</sup>

Part Name	Part No.	Dimensions (in.)					Fasteners <sup>1</sup>				Allowable Loads (lb) <sup>2</sup>																									
							Beam		Post		Southern Pine (SG=0.55)			Douglas Fir - Larch (SG=0.50)																						
		W1	W2	H1	L1	L2	Qty	Size	Qty	Size	Uplift	F1	F2	Uplift	F1	F2																				
12ga PCM	PCM44	3-9/16	3-9/16	3-9/16	2-7/16	11	12	16d	8	16d	2,120	2,050	1,955	2,085	1,855	1,795																				
	PCM46		5-9/16																																	
	PCM48		7-9/16																																	
	PCM64	5-1/2	3-9/16	3-1/2	3-13/16	11																														
	PCM66	5-9/16	13																																	
	PCM68	7-9/16	15																																	
	PCM77	7-1/8	7-1/8	3-11/16	5-5/8	14-9/16											12	16d	8	16d	2,120	2,050	1,955	2,085	1,855	1,795										
	PCM84	3-9/16	3-1/2	11																																
	PCM86	7-1/2	5-9/16	3-3/8	5-5/8	13																														
PCM88	7-9/16	3-1/2	14-5/8																																	
16ga PCM	PCM44-16	3-9/16	3-9/16	3-9/16	2-7/16	11	12	16d	8	16d	1,875	1,875	1,730	1,845	1,640	1,590																				
	PCM46-16		5-9/16			13																														
	PCM48-16		7-9/16			15																														
	PCM64-16	5-1/2	3-9/16	3-1/2	3-13/16	11																					12	16d	8	16d	1,875	1,875	1,730	1,845	1,640	1,590
	PCM66-16	5-9/16	13																																	
	PCM68-16	7-9/16	15																																	
	PCM84-16	7-1/8	3-9/16	3-1/2	5-5/8	11											12	16d	8	16d	1,875	1,875	1,730	1,845	1,640	1,590										
	PCM86-16	7-1/2	5-9/16	3-3/8	5-1/8	13																														
	PCM88-16	7-9/16	3-1/2	15																																
12ga EPCM	EPCM44	3-9/16	3-9/16	3-9/16	2-7/16	7-1/4	8	16d	8	16d	2,120	2,050	1,955	2,085	1,855	1,795																				
	EPCM46		5-9/16			9-1/4																														
	EPCM48		7-9/16			11-1/4																														
	EPCM64	5-1/2	3-9/16	3-1/2	3-13/16	7-1/4																					8	16d	8	16d	2,120	2,050	1,955	2,085	1,855	1,795
	EPCM66	5-9/16	9-1/4																																	
	EPCM68	7-9/16	11-1/4																																	
	EPCM77	7-1/8	7-1/8	3-11/16	5-5/8	10-13/16											8	16d	8	16d	2,120	2,050	1,955	2,085	1,855	1,795										
	EPCM84	3-9/16	3-1/2	7-1/4																																
	EPCM86	7-1/2	5-9/16	3-1/2	5-5/8	9-1/4																														
EPCM88	7-9/16	3-1/2	11-1/8																																	
16ga EPCM	EPCM44-16	3-9/16	3-9/16	3-9/16	2-7/16	7-1/4	8	16d	8	16d	1,875	1,815	1,730	1,845	1,640	1,590																				
	EPCM46-16		5-9/16			9-1/4																														
	EPCM48-16		7-9/16			11-1/4																														
	EPCM64-16	5-1/2	3-9/16	3-1/2	3-13/16	7-1/4																					8	16d	8	16d	1,875	1,815	1,730	1,845	1,640	1,590
	EPCM66-16	5-9/16	9-1/4																																	
	EPCM68-16	7-9/16	11-1/4																																	
	EPCM84-16	7-1/8	3-9/16	3-1/2	5-5/8	7-1/4											8	16d	8	16d	1,875	1,815	1,730	1,845	1,640	1,590										
	EPCM86-16	7-1/2	5-9/16	3-1/2	9-1/4																															
	EPCM88-16	7-9/16	3-1/2	11-1/4																																

### NOTES:

1. Nails designated as 16d shall be 16d common nails (0.162 x 3.5",  $F_{yb} = 90,000$  psi).
2. Allowable loads are provided for load duration factor ( $C_D$ ) of 1.6. No further increase is permitted.

## CCS/ECCS SERIES

### PRODUCT FEATURES:

Welded Column Caps (CCS) and End Column Caps (ECCS) are heavy post to beam connectors that uses QuickTie Structural Wood Screws for higher load rating.

### MATERIAL:

CCS – 7 ga and 3 ga

ECCS – 7 ga and 3 ga

### COATING:

Spray Painted Primer (gray)

### INSTALLATION:

- Use all specified fasteners in schedule to achieve values indicated.
- EOR to design the post and beam(s) to support the required loads.

### CODE COMPLIANCE:

Call QT for code approval information.

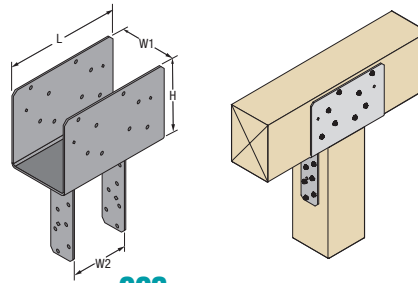

**CCS (Column Cap)**  
(Part includes structural wood screws)

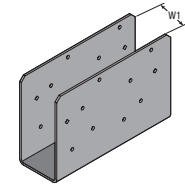

**CCSO (Column Cap w/ No Straps)**  
(Part includes structural wood screws)

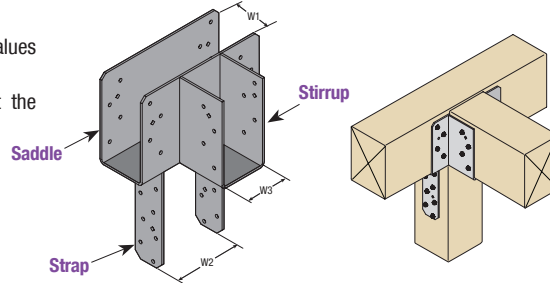

**CCST (Column Cap w/ Tee Beam)**  
(Part includes structural wood screws)

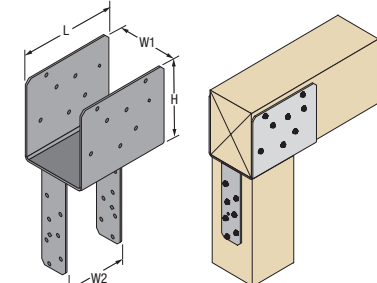

**ECCS (End Column Cap)**  
(Part includes structural wood screws)

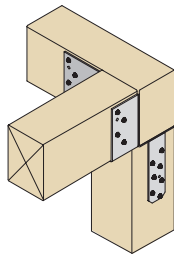

**ECCSLR (End Column Cap w/ Right Leg Beam)**  
(Part includes structural wood screws)

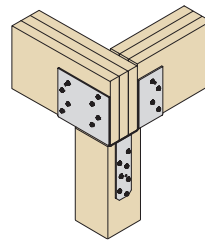
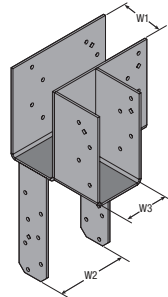

**ECCSLL (End Column Cap w/ Left Leg Beam)**  
(Part includes structural wood screws)

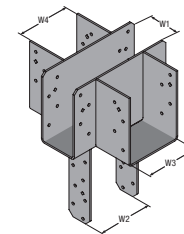

**CCSC (Column Cap w/ Cross Beams)**  
(Part includes structural wood screws)

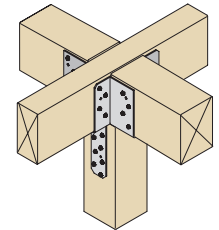

## ALLOWABLE LOADS FOR CCS (LB)<sup>1,2</sup>

	Part No.	Steel Thick., ga	Dimensions (in.)				Fastener Schedule <sup>1</sup>				Allowable Loads (lb)*	
							Beam		Post		SP/DF-L (0.50)	
			W1	W2	H	L	Qty	Type	Qty	Type	Bearing (C <sub>b</sub> = 1.0) <sup>2</sup>	Uplift (C <sub>b</sub> = 1.6) <sup>2</sup>
CCS	CCS325-4	7	3-1/4	3-5/8	7	11	16	SWH3	14	SWH3	22,560	7,420
	CCS325-6	7	3-1/4	5-1/2							22,560	
	CCS44	7	3-5/8	3-5/8							25,270	
	CCS45	7	3-5/8	5-3/8							25,270	
	CCS46	7	3-5/8	5-1/2							25,270	
	CCS4-71	7	3-5/8	7-1/8							25,270	
	CCS48	7	3-5/8	7-1/2	25,270							
	CCS525-4	3	5-1/4	3-5/8	7	11	16	SWH3	14	SWH3	43,720	7,420
	CCS525-6	3	5-1/4	5-1/2							43,720	
	CCS525-8	3	5-1/4	7-1/2							43,720	
	CCS57	3	5-3/8	7-1/8	37,900							
	CCS64	7	5-1/2	3-5/8	7	11	16	SWH3	14	SWH3	39,705	7,420
	CCS66	7	5-1/2	5-1/2							39,705	
	CCS6-71	7	5-1/2	7-1/8							39,705	
	CCS68	7	5-1/2	7-1/2							39,705	
	CCS74	3	6-7/8	3-5/8	7	11	16	SWH3	14	SWH3	48,725	7,420
	CCS76	3	6-7/8	5-1/2							48,725	
	CCS77	3	6-7/8	7-1/8							48,725	
	CCS78	3	6-7/8	7-1/2							48,725	
	CCS71-4	3	7-1/4	3-5/8							50,530	
	CCS71-6	3	7-1/4	5-1/2							50,530	
	CCS71-71	3	7-1/4	7-1/4							50,530	
	CCS71-8	3	7-1/4	7-1/2							50,530	
	CCS84	3	7-1/2	3-5/8	7	11	16	SWH3	14	SWH3	54,145	7,420
	CCS86	3	7-1/2	5-1/2							54,145	
	CCS88	3	7-1/2	7-1/2							54,145	
	CCS94	3	8-7/8	3-5/8							63,165	
	CCS96	3	8-7/8	5-1/2							63,165	
CCS98	3	8-7/8	7-1/2	63,165								
CCS106	3	9-1/2	5-1/2	68,580								

### NOTES:

1. Refer to page 71 for structural wood screw SWH3 (1/4" x 3") details.
  2. Allowable uplift loads are provided for load duration factor (C<sub>D</sub>) of 1.6. No further increase is permitted.
- \*Allowable loads per NDS calculations, call QT for code approval information.

# Post Caps

## ALLOWABLE LOADS FOR CCS & ECCS (LB)<sup>1,2</sup>

	Part No.	Steel Thick., ga	Dimensions (in.)				Fastener Schedule <sup>1</sup>				Allowable Loads (lb)*									
							Beam		Post		SP/DF-L (0.50)									
			W1	W2	H	L	Qty	Type	Qty	Type	Bearing (C <sub>b</sub> = 1.0) <sup>2</sup>	Uplift (C <sub>u</sub> = 1.6) <sup>3</sup>								
ECCS	ECCS325-4	7	3-1/4	3-5/8	7	8-1/2	14	SWH3	14	SWH3	15,385	7,205								
	ECCS325-6	7	3-1/4	5-1/2							15,385									
	ECCS44	7	3-5/8	3-5/8							17,815									
	ECCS45	7	3-5/8	5-3/8							17,225									
	ECCS46	7	3-5/8	5-1/2							19,525									
	ECCS4-71	7	3-5/8	7-1/8							21,820									
	ECCS48	7	3-5/8	7-1/2	19,525	7	8-1/2	14	SWH3	14	SWH3	23,445	7,205							
	ECCS525-4	3	5-1/4	3-5/8	28,665															
	ECCS525-6	3	5-1/4	5-1/2	31,950															
	ECCS525-8	3	5-1/4	7-1/2	32,730															
	ECCS5-71	7	5-3/8	7-1/8	24,710															
	ECCS64	7	5-1/2	3-5/8	30,355							7		8-1/2	14	SWH3	14	SWH3	30,680	7,205
	ECCS66	7	5-1/2	5-1/2	28,840															
	ECCS6-71	7	5-1/2	7-1/8	37,655															
	ECCS68	7	5-1/2	7-1/2	37,655															
	ECCS74	3	6-7/8	3-5/8	37,655															
	ECCS76	3	6-7/8	5-1/2	29,650	7	8-1/2	14	SWH3	14	SWH3		37,655						7,205	
	ECCS77	3	6-7/8	6-7/8	39,050															
	ECCS78	3	6-7/8	7-1/2	39,050															
	ECCS71-4	3	7-1/4	3-5/8	31,275							7	8-1/2	14	SWH3	14	SWH3	29,650		7,205
	ECCS71-6	3	7-1/4	5-1/2	39,260															
	ECCS71-71	3	7-1/4	7-1/4	41,835															
	ECCS71-8	3	7-1/4	7-1/2	35,275	7	8-1/2	14	SWH3	14	SWH3							44,760	7,205	
	ECCS84	7	7-1/2	3-5/8	48,810															
	ECCS86	7	7-1/2	5-1/2	48,050															
	ECCS88	7	7-1/2	7-1/2																
	ECCS94	7	8-7/8	3-5/8																
	ECCS96	7	8-7/8	5-1/2																
	ECCS98	7	8-7/8	7-1/2																
	ECCS106	7	9-1/2	5-1/2	7	8-1/2	14	SWH3	14	SWH3	48,050	7,205								

### NOTES:

- Refer to page 71 for structural wood screw SWH3 (1/4" x 3") details.
  - Allowable uplift loads are provided for load duration factor (C<sub>D</sub>) of 1.6. No further increase is permitted.
- \*Allowable loads per NDS calculations, call QT for code approval information.

## PCS/PCES SERIES

### PRODUCT FEATURES:

PCS and PCES are post caps and end post caps used for post-to-beam connection applications.

### MATERIAL:

PCS/PCES – 18 ga

### COATING:

Galvanized (G185)



### INSTALLATION:

- Use all specified fasteners in schedule to achieve values indicated.

### CODE COMPLIANCE:

TER 0910-01, FL 3557

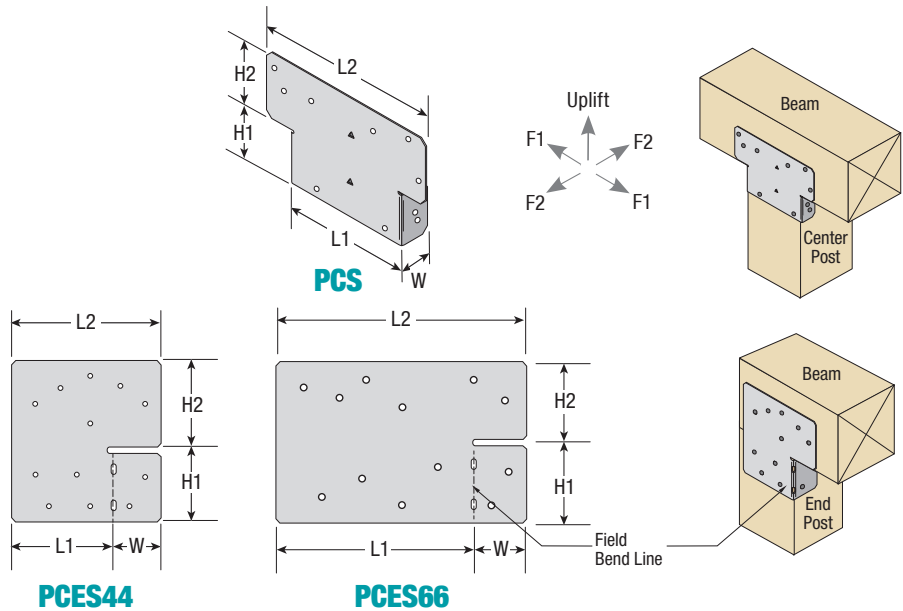

## ALLOWABLE LOADS FOR PCS/PCES (LB)<sup>1,2</sup>

Part No.	Part No.	Dimensions					Fasteners Per Pair of Post Caps			Allowable Loads (lb) Per Pair of Post Caps (C <sub>D</sub> = 1.6)						
		Width (in.)		Length (in.)		Height		Nail Size	Quantity		SP (0.55)		DF-L (0.50)		HF/S-P-F (0.42)	
		W	L1	L2	H1	H2	Beam		Post	Uplift	F1	Uplift	F1	Uplift	F1	
PCS	PCS44	1-3/8	3-9/16	6-1/4	2-5/8	2-7/8	16d Common (0.162 x 3.5")	12	12	2,935	2,175	2,295	1,950	2,295	1,870	
	PCS44R	1-1/2	4	7												
	PCS66	1-1/4	5-1/2	8												
	PCS66R	1-1/2	6	9												
PCES	PCES44	1-1/2	3-1/4	4-3/4	2-3/8	2-3/4	16d Common (0.162 x 3.5")	12	12	1,955	1,500	1,800	1,220	1,550	1,090	
	PCES66	1-1/2	5-1/2	7	2-3/8	2-1/8	16d Common (0.162 x 3.5")	12	12	1,645	1,205	1,520	925	1,310	835	

### NOTES:

- Allowable loads and fastener size/quantity provided are for a pair of post caps and end post caps.
- Allowable loads are provided for a load duration factor (C<sub>D</sub>) of 1.6. No further increase is permitted.

## NAIL PROTECTION PLATES (NPP)

### PRODUCT FEATURES:

The NPP Series protects electrical wires and plumbing lines from damage caused by nails, screws, and other piercing hazards. Built-in prongs provide fast, secure installation and meet IBC, IRC, IPC, and NEC code requirements.

### MATERIAL:

NPP1, NPP2 - 14 ga  
NPP58, NPP516 - 16 ga

### COATING:

Galvanized (G185)

### INSTALLATION:

- Use all specified fasteners in schedule to achieve values indicated and/or install using the built-in prongs.

### CODE COMPLIANCE:

Call QT for code approval information.

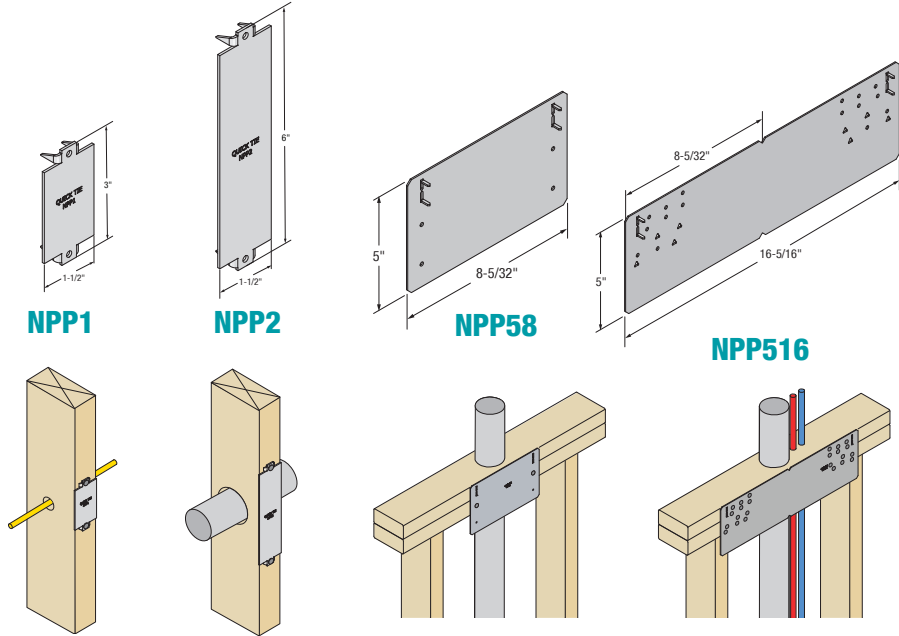

## ALLOWABLE LOADS FOR NPP<sup>1</sup>

Part No.	Width, W (in.)	Length, L (in.)	Fasteners		Allowable Tension	
			Qty	Type	SP/DF-L	HF/SPF
NPP1	1-1/2	3	-	-	-	-
NPP2	1-1/2	6	-	-	-	-
NPP58	5	8-5/32	-	-	-	-
NPP516	5	16-5/16	12	16d	1,390	1,200
			16	16d	1,855	1,600
			24	16d	2,780	2,400

### NOTES:

- Allowable loads are provided for a load duration factor ( $C_D$ ) of 1.6. No further increase is permitted.

## TENSION-COMPRESSION STRAPS (TCS)

### PRODUCT FEATURES:

Tension-Compression Straps (TCS) are connectors designed to bridge/repair discontinuous wood members (i.e. top plates, studs, trusses, etc.) by transferring axial loads from one member to the other connected member. TCS18-3Z strap may span gaps up to 4-1/2" and the TCS20-3Z may span gaps up to 6". Both straps have a nominal width of 1-1/2" which allows installation on the narrow face of nominal 2x wood members.

### MATERIAL:

TCS - 14 ga

### COATING:

Galvanized (G185)

### INSTALLATION:

- Use all specified fasteners in schedule to achieve values indicated.

### CODE COMPLIANCE:

TER 0910-01, FL 3557

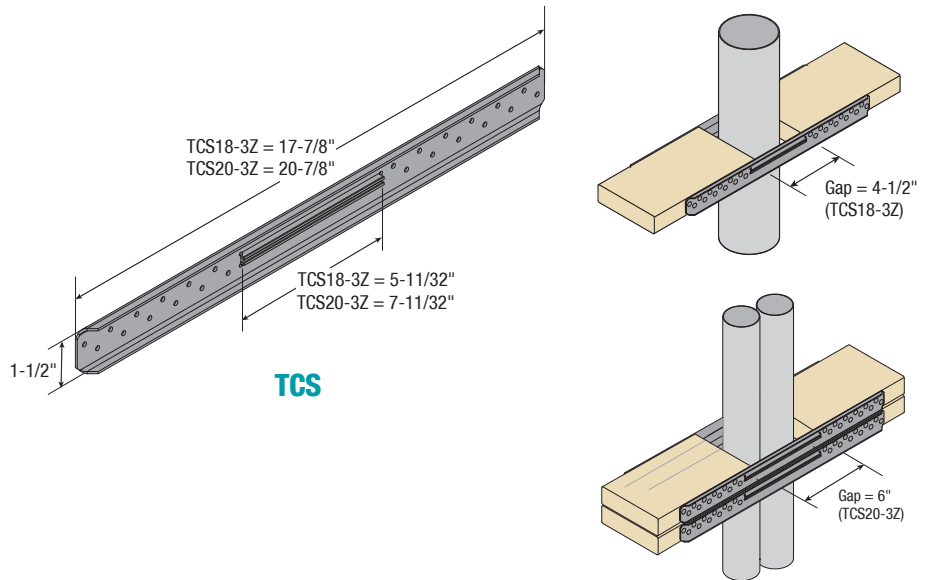

## TENSION-COMPRESSION STRAPS - ALLOWABLE COMPRESSION AND TENSION VALUES

Part No.	Installed On	Number of Straps	Fasteners Per Strap		Allowable Loads (lb) <sup>1</sup> ( $C_D = 1.6$ )			
			Type	Qty	SP/DF-L		HF/SPF	
					Compression	Tension	Compression	Tension
TCS18-3Z	One Side	1	10d x 1-1/2" (0.148 x 1.50")	24	1,270	2,465	1,100	2,130
		2			2,330	4,930	2,015	4,265
TCS20-3Z	Two Sides	2 (total)			2,330	4,930	2,015	4,265
		3 (total)			3,600	7,390	3,115	6,395
		4 (total)			4,660	9,855	4,030	8,530

### NOTES:

- Allowable loads are provided for a load duration factor ( $C_D$ ) of 1.6. No further increase is permitted.

# Top Mount Joist Hangers

## TOP FLANGE HANGERS (TFLP & TFH)

### PRODUCT FEATURES:

Top Flange U-Hanger Series are top mount joist hangers used to resist gravity loads and uplift loads due to wind in single or multi-ply joist assembly in light-frame construction.

### MATERIAL:

TFLP Series - 18 ga  
TFH Series - 14 ga

### COATING:

Galvanized (G185)

### CODE COMPLIANCE:

TER 1811-03, FL 3557

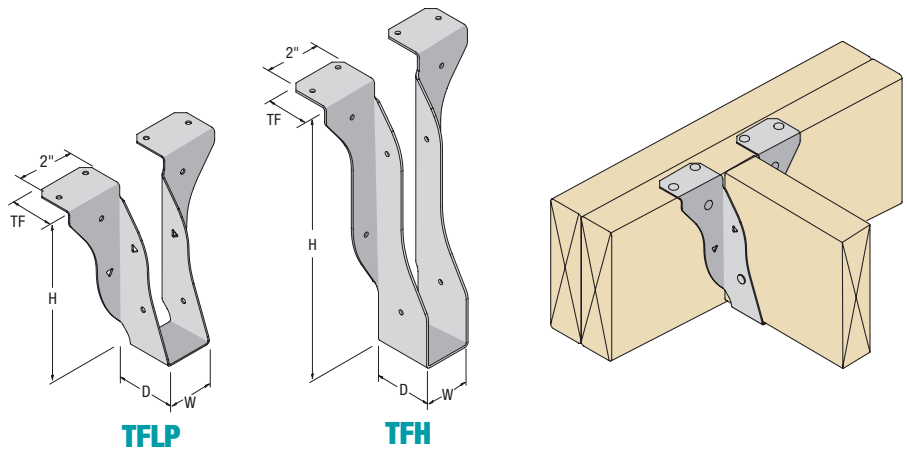

## ALLOWABLE LOADS FOR TOP FLANGE HANGERS (LB)

Part No.	Joist Size (IN.)	Hanger Dimensions (in.)				Fasteners				SP (SG = 0.55)				DF-L (SG = 0.50)				HF/SPF (SG = 0.42)			
		Width, W	Height, H	Depth, D	Top Flange TF	Header		Joist		Floor	Roof	Roof	Uplift	Floor	Roof	Roof	Uplift	Floor	Roof	Roof	Uplift
						Qty.	Size	Qty.	Size	1.0	1.15	1.25	1.6	1.0	1.15	1.25	1.6	1.0	1.15	1.25	1.6
TFLP26	2x6	1-9/16	5-3/8	1-1/2	1-5/16	6	16d Common	2	10d x 1-1/2	1,280	1,280	1,280	230	1,245	1,245	1,245	230	945	945	945	165
TFLP28	2x8		7-1/4							225											
TFH210	2x10	1-9/16	9-3/16	2	1-7/16	8	16d Common	4	10d x 1-1/2	1,765	1,765	1,765	380	1,535	1,535	1,535	380	1,165	1,165	1,165	285
TFH212	2x12		11-1/8																		
TFH214	2x14		13-1/8																		

### NOTES:

- Nails designated as 16d shall be 16d common nails (0.162" x 3.5", F<sub>y</sub>b = 90,000 psi).
- Allowable loads are provided for load duration factor (C<sub>D</sub>) of 1.0, 1.15, 1.25 and 1.6.
- Allowable loads labeled "Floor" and "Roof" represent gravity loads.

## TOP FLANGE HEAVY HANGERS - TFHD SERIES

### PRODUCT FEATURES:

The Top Flange Heavy (TFHD) U-Hanger Series are top-mounted joist hangers that resist gravity and wind uplift loads in single- or multi-ply joist assemblies for light-frame construction.

### MATERIAL:

TFHD - 12 ga

### COATING:

Galvanized (G185)

### INSTALLATION:

- Use all specified fasteners in schedule to achieve values indicated.

### CODE COMPLIANCE:

Call QT for code approval information.

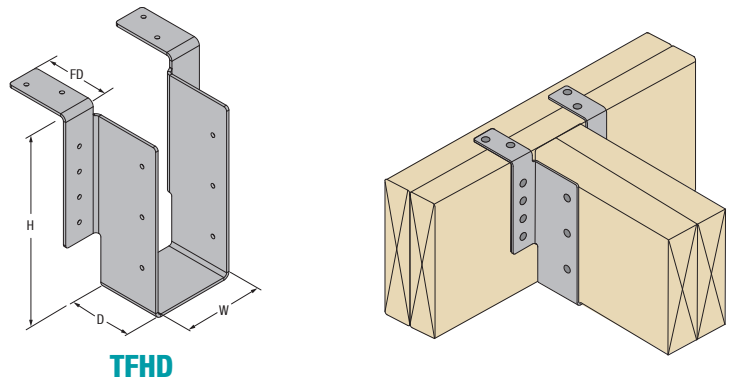

## TOP FLANGE HEAVY HANGERS - ALLOWABLE COMPRESSION AND TENSION VALUES<sup>1</sup>

Part No.	Width W (in.)	Height H <sup>2</sup> (in.)	Depth D (in.)	Fl. Depth FD (in.)	Fasteners				Allowable loads (SP/DF-L)			
					Header		Joist		Uplift	Gravity		
					Qty	Type	Qty	Type	1.6	1	1.15	1.25
TFHD26	1-9/16	5-3/8	2-1/2	2-1/2	12	16d	6	10d x 1-1/2	960	2,635	2,800	2,915
TFHD28		7-1/8			12	16d	6	10d X 1-1/2	960	2,915	3,125	3,265
TFHD210		9-1/8			14	16d	8	10d X 1-1/2	1,280	2,915	3,125	3,265
TFHD212	3-1/8	11	2-1/2	2-1/2	18	16d	8	10d x 1-1/2	1,280	3,475	3,770	3,965
TFHD26-2		5-3/8			12	16d	6	16d	1,220	4,150	4,315	4,430
TFHD28-2		7-1/8			12	16d	6	16d	1,220	4,150	4,315	4,430
TFHD210-2		9-1/8			16	16d	8	16d	1,625	4,710	4,960	5,130
TFHD212-2		11			18	16d	8	16d	1,625	4,990	5,280	5,480
TFHD46		5-3/8			12	16d	6	16d	1,220	4,150	4,315	4,430
TFHD410	3-9/16	9-1/8	2-1/2	2-1/2	16	16d	8	16d	1,625	4,710	4,960	5,130
TFHD412		11			16	16d	8	16d	1,625	4,710	4,960	5,130
TFHD414		13			20	16d	10	16d	2,030	5,270	5,605	5,830
TFHD610	5-1/2	9-1/8	2-1/2	2-1/2	16	16d	8	16d	1,625	4,710	4,960	5,130
TFHD612		11			18	16d	8	16d	1,625	4,990	5,280	5,480
TFHD614		13			20	16d	10	16d	2,030	5,270	5,605	5,830

### NOTES:

- Allowable loads are provided for a load duration factor (C<sub>D</sub>) of 1.6. No further increase is permitted.

## TOP FLANGE HEAVY BEAM HANGERS (TFHBH)

### PRODUCT FEATURES:

Top Flange Header Beam Hangers (TFHBH) are heavy header-to-beam connectors used for supporting and transferring high loads from the LVL, LSL and PSL beams to the header.

### MATERIAL:

TFHBH35X – 7 ga  
TFHBH55X – 7 ga (Saddle) & 3 ga (Top Flange)

### COATING:

Spray Painted Primer (gray)

### CODE COMPLIANCE:

Call QT for code approval information.

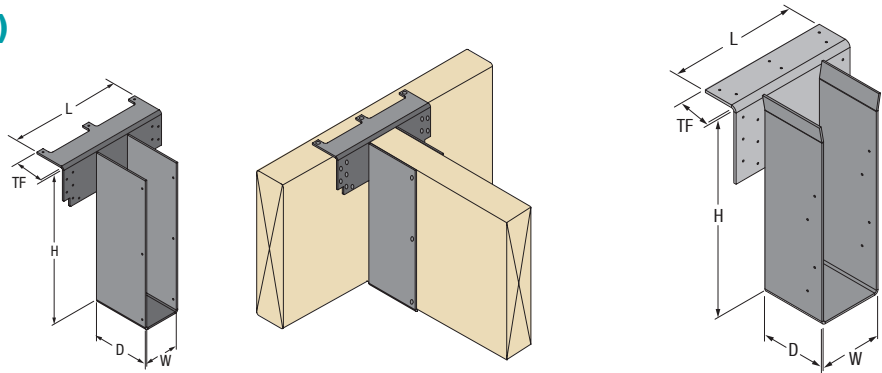

**TFHBH35X**

**TFHBH55X**

## ALLOWABLE LOADS FOR TOP FLANGE HEAVY BEAM HANGERS (LB)\*

Part No.	Hanger Dimensions (in.)					Fastener Quantity					Allowable loads (lb)*	
	Height, H	Width, W	Depth, D	Length, L	Top Flange TF	Header			Joist		SP (0.55) / DF-L (0.50)	
						Top	Face	Type	Qty	Type	Gravity (C <sub>D</sub> = 1.0)	Uplift (C <sub>D</sub> = 1.6)
TFHBH3512	12	3-5/8	6	12	3-1/8	3	12	16d	6	16d	10,545	1,490
TFHBH3514	14											
TFHBH3516	16											
TFHBH3518	18											
TFHBH3520	20											
TFHBH3595	9-1/2	5-9/16	6	12	3-1/8	6	12	16d	8	16d	10,545	1,490
TFHBH5514	14											
TFHBH5516	16											
TFHBH5518	18											

\*For other sizes, contact QT. Allowable loads per NDS nail calculations, call QT for code approval information.

## FACE MOUNT GIRDER HANGERS - ULG, UMG & UHG SERIES

### PRODUCT FEATURES:

The ULG, UMG, and UHG series hangers are light-, medium-, and heavy-capacity girder hangers designed to resist high wind uplift and gravity loads by using wood screws (SWH) instead of standard nails. These are available with one or both flanges inverted for corner attachments or where a concealed option is needed.

### MATERIAL:

ULG & UMG - 10 ga  
UHG - 7 ga

### COATING:

Spray-painted gray primer

### INSTALLATION:

- Use all specified fasteners in schedule to achieve values indicated.

### CODE COMPLIANCE:

Call QT for code approval information.

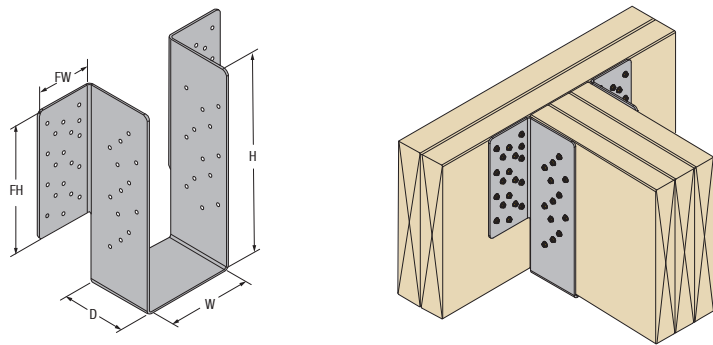

**ULG/UMG/UHG**

## GIRDER HANGERS - ALLOWABLE COMPRESSION AND TENSION VALUES<sup>1,2</sup>

Part No.	Steel Thick. (ga)	Width W (in.)	Height H <sup>2</sup> (in.)	Depth D (in.)	Fl. Height FH (in.)	Fl. Width FW (in.)	Fasteners				Allowable loads (SP/DF-L)			Allowable loads (HF/SPF)		
							Face		Joist		Uplift	Gravity		Uplift	Gravity	
							Qty	Type	Qty	Type		1.6	1		1.15/1.25	1.6
ULG325	10	3-1/4	8 to 30	4-1/2	7-3/8	3-1/4	16	SWH3	12	SWH3	7,255	8,060	8,060	6,090	6,770	6,770
ULG363	10	3-5/8														
ULG525	10	5-1/4														
UMG363	10	3-5/8	9-1/4 to 30	4-1/2	8-5/8	4	24	SWH3	16	SWH3	8,060	10,580	10,580	6,770	8,885	8,885
UMG525	10	5-1/4														
UMG550	10	5-1/2														
UMG562	10	5-5/8														
UMG700	10	7														
UHG363	7	3-5/8	11 to 30	5-1/4	10-3/8	4-3/4	36	SWH3	24	SWH3	10,135	14,255	14,255	8,510	11,970	11,970
UHG525	7	5-1/4														
UHG550	7	5-1/2														
UHG562	7	5-5/8														
UHG700	7	7														
UHG725	7	7-1/4														
UHG900	7	9														
UHG110	7	11														

### NOTES:

- Allowable loads are provided for a load duration factor (C<sub>D</sub>) of 1.6. No further increase is permitted.
- Customer to specify the joist height. Other seat widths and inverted flange parts available upon request.

# Face Mount Hangers

## U HANGERS AND INVERTED FLANGE U HANGERS (ULU, UL, ULP, ULP-IF, UM, UH & UH-IF SERIES)

### PRODUCT FEATURES:

U-Hanger and Inverted Flange (IF) U-Hanger Series are face mount joist hangers used to resist gravity loads and uplift loads due to wind in one-, two- and three-ply joist assemblies in light-frame wood construction. These are used as wood framing connectors in accordance with IBC Section 2304.10.4 and IRC Section R301.1.3.

### MATERIAL:

- ULU Series\* - 20 ga
- UL Series - 20 ga
- ULP & ULP-IF Series - 18 ga
- UM Series - 16 ga
- UH & UH-IF Series - 14 ga

### COATING:

Galvanized (G185)

### INSTALLATION:

- Use all specified fasteners in schedule to achieve values indicated.
- All U-Hangers have slant nailing. These must be used to achieve published load values. The nails must be driven at an angle (approx. 41°) in the joist and into the header.
- For all Hangers, use 16d common nails (0.162 x 3-1/2") for hanger-to-header attachment.
- For all Inverted Flange (IF) Hangers, use 10d common nails (0.148 x 3") for hanger-to-joist attachment.
- Hangers are not allowed to be modified.
- Hangers are not designed for welded applications.

### CODE COMPLIANCE:

TER 1811-03; FL 3557



### TYPICAL INVERTED FLANGE (IF) U HANGERS

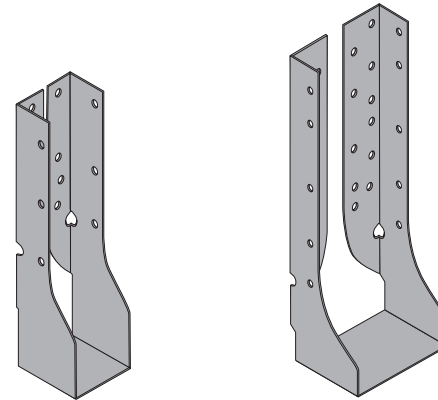
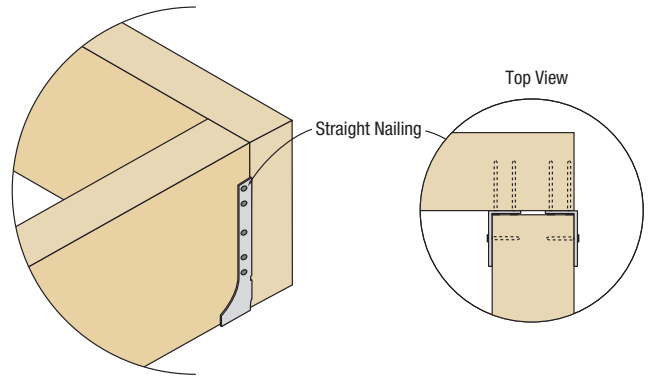
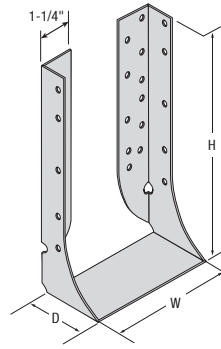

ULP-IF

UH-IF

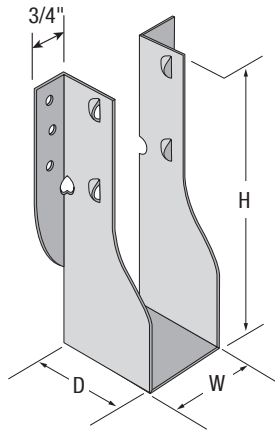

### TYPICAL U HANGERS

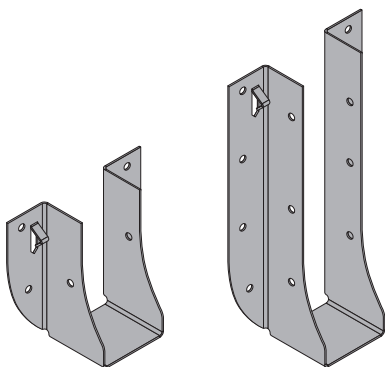
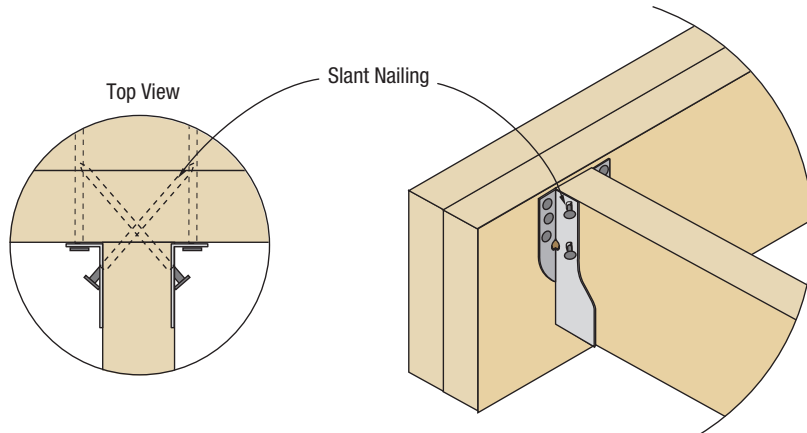

ULU24

ULU28

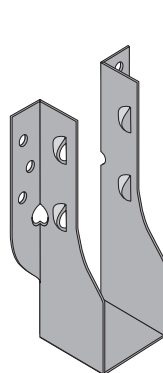

UL

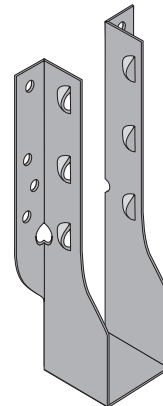

ULP

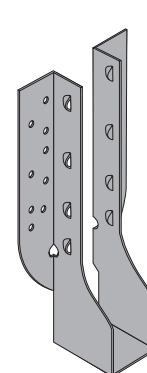

UM

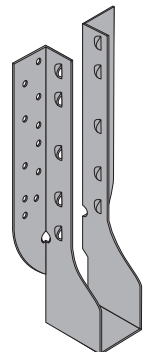

UH

NOTE: Similar for 2-ply & 3-ply joist hangers

## ALLOWABLE LOADS FOR UL, ULP, UM & UH SERIES HANGERS (LB)<sup>1,2,3</sup>

Joist Size		Part No.			QUICKTIE PART ATTRIBUTES																	
					Steel Thick.	Hanger Dimensions (in.)			Fasteners				SP/DF-L (SG = 0.50)				HF/SPF (SG = 0.42)					
		QT	Reference No. <sup>4</sup>			Width, W	Height, H	Depth, D	Header		Joist		Floor	Roof	Roof	Uplift	Floor	Roof	Roof	Uplift		
			Simpson® Hardware (SH)	MiTek® Hardware (MH)					Qty	Size	Qty	Size									1.0	1.15
2 x 4	2x4	1-ply	ULU24	LU24	JL24	20 ga	1-9/16	3-1/8	1-1/2	4	16d	2	10d x 1-1/2	555	635	690	370	475	545	595	320	
		1-ply	ULP24	LUS24, U24	JUS24, SUH24	18 ga	1-5/8	3-1/8	1-3/4	6	10d	2	10d or 10dx1-1/2	500	500	500	380	430	430	430	325	
		2-ply	ULP24-2	LUS24-2, U24-2	JUS24-2, SUH24-2	18 ga	3-1/8	3-1/8	1-3/4	6	16d	2	10d or 10dx1-1/2	805	805	805	380	580	580	580	325	
2 x 6	2x6	1-ply	ULU26	LU26	JL26	20 ga	1-9/16	4-3/4	1-1/2	6	16d	4	10d x 1-1/2	830	955	1,040	740	715	820	895	640	
		1-ply	UL26	LUS26	JUS26	20 ga	1-5/8	5-3/8	1-3/4	6	16d	4	16d	1,215	1,215	1,215	510	965	965	965	440	
		1-ply	ULP26	MUS26	MUS26	18 ga	1-5/8	5-3/8	1-3/4	6	16d	4	16d	1,230	1,415	1,435	670	1,065	1,110	1,110	580	
		Rough	ULP26R	LU26R-18	-	18 ga	2	5-1/8	1-3/4	6	16d	4	16d	1,230	1,415	1,435	670	1,065	1,110	1,110	580	
		1-ply	UM26	U26	SUH26	16 ga	1-5/8	5-3/8	2-1/4	6	16d	6	16d	1,445	1,540	1,540	600	1,245	1,245	1,245	525	
		Rough	UM26R	U26R	SUH26R	16 ga	2	5-3/16	2-1/4	6	16d	6	16d	1,445	1,540	1,540	600	1,245	1,245	1,245	525	
	(2) 2x6	1-ply	UH26	HU26	HD26	14 ga	1-5/8	5-3/8	2-1/4	6	16d	6	16d	1,465	1,540	1,540	1,155	1,205	1,205	1,205	1,005	
		2-ply	UL26-2	-	-	20 ga	3-1/8	4-5/8	1-3/4	6	16d	4	16d	1,215	1,215	1,215	510	965	965	965	440	
		2-ply	ULP26-2	LUS26-2, LUS26-2Z	JUS26-2, JUS26-2TZ	18 ga	3-1/8	4-5/8	1-3/4	6	16d	4	16d	1,230	1,415	1,435	670	1,065	1,110	1,110	580	
		2-ply	UM26-2	U26-2	SUH26-2	16 ga	3-1/8	4-5/8	2-1/4	6	16d	6	16d	1,445	1,540	1,540	600	1,245	1,245	1,245	525	
		2-ply	UH26-2	HUS26-2, HU26-2	HUS26-2, HD26-2	14 ga	3-1/8	4-5/8	2-1/4	6	16d	6	16d	1,465	1,540	1,540	1,170	1,205	1,205	1,205	1,015	
		3-ply	UL26-3	-	-	20 ga	4-5/8	3-7/8	1-3/4	6	16d	4	16d	1,215	1,215	1,215	510	965	965	965	440	
(3) 2x6	3-ply	ULP26-3	LUS26-3	JUS26-3	18 ga	4-5/8	3-7/8	1-3/4	6	16d	4	16d	1,230	1,415	1,435	670	1,065	1,110	1,110	580		
	3-ply	UM26-3	U26-3	SUH26-3	16 ga	4-5/8	3-7/8	2-1/4	6	16d	6	16d	1,445	1,540	1,540	600	1,245	1,245	1,245	525		
	3-ply	UH26-3	HU26-3	HD26-3	14 ga	4-5/8	3-7/8	2-1/4	6	16d	6	16d	1,465	1,540	1,540	1,155	1,205	1,205	1,205	1,005		
	3-ply	UH26-3	HU26-3	HD26-3	14 ga	4-5/8	3-7/8	2-1/4	6	16d	6	16d	1,465	1,540	1,540	1,155	1,205	1,205	1,205	1,005		
2 x 8	2x8	1-ply	ULU28	LU28	JL28	20 ga	1-9/16	6-3/8	1-1/2	8	16d	6	10d x 1-1/2	1,105	1,275	1,385	1,115	950	1,095	1,190	955	
		1-ply	UL28	LUS28, LUS28Z	JUS28, JUS28-TZ	20 ga	1-5/8	7-1/8	1-3/4	8	16d	6	16d	1,695	1,855	1,895	910	1,400	1,455	1,490	785	
		1-ply	ULP28	MUS28	MUS28	18 ga	1-5/8	7-1/8	1-3/4	8	16d	6	16d	1,710	1,955	2,005	1,025	1,450	1,525	1,560	890	
		Rough	ULP28R	LU28R-18	-	18 ga	2	6-7/8	1-3/4	8	16d	6	16d	1,710	1,955	2,005	1,025	1,450	1,525	1,560	890	
		1-ply	UM28	-	SUH28	16 ga	1-5/8	7-1/8	2-1/4	12	16d	6	16d	1,885	1,930	1,930	600	1,625	1,625	1,625	525	
		Rough	UM28R	U26R	SUH28R	16 ga	2	6-15/16	2-1/4	12	16d	6	16d	1,885	1,930	1,930	600	1,625	1,625	1,625	525	
	(2) 2x8	1-ply	UH28	HU28	HD28	14 ga	1-5/8	7-1/8	2-1/4	12	16d	6	16d	1,865	1,960	1,985	1,155	1,495	1,525	1,550	1,005	
		2-ply	UL28-2	-	-	20 ga	3-1/8	6-3/8	1-3/4	8	16d	6	16d	1,695	1,855	1,895	910	1,400	1,455	1,490	785	
		2-ply	ULP28-2	LUS28-2, LUS28-2Z	JUS28-2, JUS28-2TZ	18 ga	3-1/8	6-3/8	1-3/4	8	16d	6	16d	1,710	1,955	2,005	1,025	1,450	1,525	1,560	890	
		2-ply	UM28-2	-	SUH28-2	16 ga	3-1/8	6-3/8	2-1/4	12	16d	6	16d	1,885	1,930	1,930	600	1,625	1,625	1,625	525	
		2-ply	UH28-2	HUS28-2	HUS28-2	14 ga	3-1/8	6-3/8	2-1/4	12	16d	6	16d	1,865	1,960	1,985	1,155	1,495	1,525	1,550	1,005	
		3-ply	UL28-3	-	-	20 ga	4-5/8	5-5/8	1-3/4	8	16d	6	16d	1,695	1,855	1,895	910	1,400	1,455	1,490	785	
	(3) 2x8	3-ply	ULP28-3	LUS28-3, LUS28-3Z	JUS28-3, JUS28-3TZ	18 ga	4-5/8	5-5/8	1-3/4	8	16d	6	16d	1,710	1,955	2,005	1,025	1,450	1,525	1,560	890	
		3-ply	UM28-3	-	-	16 ga	4-5/8	5-5/8	2-1/4	12	16d	6	16d	1,885	1,930	1,930	600	1,625	1,625	1,625	525	
		3-ply	UH28-3	-	HD28-3	14 ga	4-5/8	5-5/8	2-1/4	12	16d	6	16d	1,865	1,960	1,985	1,155	1,495	1,525	1,550	1,005	
		3-ply	UH28-3	-	HD28-3	14 ga	4-5/8	5-5/8	2-1/4	12	16d	6	16d	1,865	1,960	1,985	1,155	1,495	1,525	1,550	1,005	
	2 x 10	2x10	1-ply	UL210	LU210, LUS210, U210	JL210, JUS210, SUH210, SUH210-TZ	20 ga	1-5/8	9-1/8	1-3/4	10	16d	8	16d	2,175	2,495	2,575	1,315	1,835	1,940	2,010	1,130
			1-ply	ULP210	-	-	18 ga	1-5/8	9-1/8	1-3/4	10	16d	8	16d	2,190	2,495	2,575	1,375	1,835	1,940	2,010	1,200
Rough			ULP210R	LU210R-18	-	18 ga	2	8-7/8	1-3/4	10	16d	8	16d	2,190	2,495	2,575	1,375	1,835	1,940	2,010	1,200	
Rough			UM210R	U210R	SUH210R	16 ga	2	8-15/16	2-1/4	18	16d	8	16d	2,320	2,320	2,320	1,065	2,005	2,005	2,005	925	
(2) 2x10		1-ply	UH210	HU210	HD210	14 ga	1-5/8	9-1/8	2-1/4	18	16d	8	16d	2,265	2,375	2,425	1,565	1,780	1,850	1,890	1,365	
		2-ply	UL210-2	-	-	20 ga	3-1/8	8-3/8	1-3/4	10	16d	8	16d	2,175	2,495	2,575	1,315	1,835	1,940	2,010	1,130	
		2-ply	ULP210-2	LUS210-2, LUS210-2Z	JUS210-2, JUS210-2TZ	18 ga	3-1/8	8-3/8	1-3/4	10	16d	8	16d	2,190	2,495	2,575	1,375	1,835	1,940	2,010	1,200	
		2-ply	UM210-2	U210-2	SUH210-2	16 ga	3-1/8	8-3/8	2-1/4	18	16d	8	16d	2,320	2,320	2,320	1,065	2,005	2,005	2,005	925	
2-ply	UH210-2	HUS210-2	HUS210-2	14 ga	3-1/8	8-3/8	2-1/4	18	16d	8	16d	2,265	2,375	2,425	1,565	1,780	1,850	1,890	1,365			

Continued on next page.

### NOTES:

- Nails designated as 16d shall be 16d common nails (0.162" x 3.5", F<sub>y</sub> = 90,000 psi), 10d shall be 10d common nails (0.148" x 3", F<sub>y</sub> = 90,000 psi) and 10d x 1-1/2 shall be 0.148" x 1.5", F<sub>y</sub> = 90,000 psi.
- Allowable loads are provided for load duration factor (C<sub>D</sub>) of 1.0, 1.15, 1.25 and 1.6.
- Allowable loads labeled "Floor" and "Roof" represent gravity loads.
- These Reference Numbers above are for the purpose of enabling our customers to identify the QuickTie™ alternative to specified product names, but the attributes of the products references (particularly load values) may differ from the QuickTie™ part. Please note that product comparison via Reference Numbers is for general application comparison only. Reference Numbers should not be used as an apples-to-apples substitution tool. Customers are solely responsible for comparing specific load values, fastener schedules, anchoring requirements, material specifications, and other factors when determining the suitability of use of any particular product. QuickTie™ makes no claim, stated or implied, of suitability for purpose or qualification for usage of our products that may be substituted for a specified product. Any specification, submittal, or change to a specified product should be approved in writing by the designer or Engineer of Record (EOR). MiTek® and Simpson Strong-Tie® are registered trademarks of their respective companies, with which QuickTie™ is unaffiliated, and neither of whom endorse or approve use of their product names in this catalog as "reference numbers".

# Face Mount Hangers

## ALLOWABLE LOADS FOR UL, ULP, UM & UH SERIES HANGERS (LB)<sup>1,2,3</sup>

Joist Size	Part No.				QUICKTIE PART ATTRIBUTES																	
	QT	Reference No. <sup>4</sup>		Steel Thick.	Hanger Dimensions (in.)			Fasteners				SP/DF-L (SG = 0.50)				HF/SPF (SG = 0.42)						
		Simpson® Hardware (SH)	MiTek® Hardware (MH)		Width, W	Height, H	Depth, D	Header		Joist Qty	Joist Size	Floor 1.0	Roof 1.15	Roof 1.25	Uplift 1.6	Floor 1.0	Roof 1.15	Roof 1.25	Uplift 1.6			
								Qty	Size													
2 x 10	(3) 2x10	3-ply	UL210-3	-	-	20 ga	4-5/8	7-5/8	1-3/4	10	16d	8	16d	2,175	2,495	2,575	1,315	1,835	1,940	2,010	1,130	
		3-ply	ULP210-3	LUS210-3, LUS210-3Z	JUS210-3, JUS210-3TZ	18 ga	4-5/8	7-5/8	1-3/4	10	16d	8	16d	2,190	2,495	2,575	1,375	1,835	1,940	2,010	1,200	
		3-ply	UM210-3	U210-3	SUH210-3	16 ga	4-5/8	7-5/8	2-1/4	18	16d	8	16d	2,320	2,320	2,320	1,065	2,005	2,005	2,005	925	
		3-ply	UH210-3	HU210-3, HU210-3Z	HD210-3	14 ga	4-5/8	7-5/8	2-1/4	18	16d	8	16d	2,265	2,375	2,425	1,565	1,780	1,850	1,890	1,365	
2 x 12	2x12	1-ply	UL212	-	-	20 ga	1-5/8	10-3/16	1-3/4	10	16d	10	16d	1,570	1,570	1,570	1,715	1,265	1,265	1,265	1,475	
		1-ply	ULP212	-	-	18 ga	1-5/8	10-3/16	1-3/4	10	16d	10	16d	2,265	2,265	2,265	1,730	1,825	1,825	1,825	1,510	
		1-ply	UH212	HU212	HD212	14 ga	1-5/8	10-3/16	2-1/4	22	16d	10	16d	3,060	3,210	3,310	1,975	2,355	2,490	2,575	1,720	
	(2) 2x12	2-ply	UL212-2	-	-	20 ga	3-1/8	9-7/16	1-3/4	10	16d	10	16d	1,570	1,570	1,570	1,715	1,265	1,265	1,265	1,475	
		2-ply	ULP212-2	-	-	18 ga	3-1/8	9-7/16	1-3/4	10	16d	10	16d	2,265	2,265	2,265	1,730	1,825	1,825	1,825	1,510	
		2-ply	UH212-2	HUS212-2	HUS212-2	14 ga	3-1/8	9-7/16	2-1/4	22	16d	10	16d	3,060	3,210	3,310	1,975	2,355	2,490	2,575	1,720	
	(3) 2x12	3-ply	UL212-3	-	-	20 ga	4-5/8	8-11/16	1-3/4	10	16d	10	16d	1,570	1,570	1,570	1,715	1,265	1,265	1,265	1,475	
		3-ply	ULP212-3	-	-	18 ga	4-5/8	8-11/16	1-3/4	10	16d	10	16d	2,265	2,265	2,265	1,730	1,825	1,825	1,825	1,510	
		3-ply	UH212-3	HU212-3	HD212-3	14 ga	4-5/8	8-11/16	2-1/4	22	16d	10	16d	3,060	3,210	3,310	1,975	2,355	2,490	2,575	1,720	
	3 x	3x6	1-ply	ULP36	LUS36, LUS36Z	JUS36, JUS36-TZ	18 ga	2-9/16	4-7/8	1-3/4	6	16d	4	16d	1,230	1,415	1,435	670	1,065	1,110	1,110	580
1-ply			UM36	U36	SUH36	16 ga	2-9/16	4-7/8	2-1/4	6	16d	6	16d	1,445	1,540	1,540	600	1,245	1,245	1,245	525	
1-ply			UH36	HU36	HD36	14 ga	2-9/16	4-7/8	2-1/4	6	16d	6	16d	1,465	1,540	1,540	1,155	1,205	1,205	1,205	1,005	
3x8		1-ply	ULP38	-	JUS38	18 ga	2-9/16	6-5/8	1-3/4	8	16d	6	16d	1,710	1,955	2,005	1,025	1,450	1,525	1,560	890	
		1-ply	UM38	-	-	16 ga	2-9/16	6-5/8	2-1/4	12	16d	6	16d	1,885	1,930	1,930	600	1,625	1,625	1,625	525	
		1-ply	UH38	HU38	HD38	14 ga	2-9/16	6-5/8	2-1/4	12	16d	6	16d	1,865	1,960	1,985	1,155	1,495	1,525	1,550	1,005	
3x10		1-ply	ULP310	LUS310	JUS310	18 ga	2-9/16	8-5/8	1-3/4	10	16d	8	16d	2,190	2,495	2,575	1,375	1,835	1,940	2,010	1,200	
		1-ply	UM310	U310	SUH310	16 ga	2-9/16	8-5/8	2-1/4	18	16d	8	16d	2,320	2,320	2,320	1,065	2,005	2,005	2,005	925	
		1-ply	UH310	HU310	HD310	14 ga	2-9/16	8-5/8	2-1/4	18	16d	8	16d	2,265	2,375	2,425	1,565	1,780	1,850	1,990	1,365	
3x12		1-ply	ULP312	-	-	18 ga	2-9/16	9-11/16	1-3/4	10	16d	10	16d	2,265	2,265	2,265	1,730	1,825	1,825	1,825	1,510	
		1-ply	UH312	HU312	HD312	14 ga	2-9/16	9-11/16	2-1/4	22	16d	10	16d	3,060	3,210	3,310	1,975	2,355	2,490	2,575	1,720	
4 x		4x6	1-ply	ULP46	LUS46, LUS46Z	JUS46, JUS46-TZ	18 ga	3-9/16	4-3/8	1-3/4	6	16d	4	16d	1,230	1,415	1,435	670	1,065	1,110	1,110	580
			1-ply	UM46	U46	SUH46	16 ga	3-9/16	4-3/8	2-1/4	6	16d	6	16d	1,445	1,540	1,540	600	1,245	1,245	1,245	525
			Rough	UM46R	U46R	SUH46R	16 ga	4	4-3/16	2-1/4	6	16d	6	16d	1,445	1,540	1,540	600	1,245	1,245	1,245	525
	1-ply		UH46	HUS46	HUS46	14 ga	3-9/16	4-3/8	2-1/4	6	16d	6	16d	1,465	1,540	1,540	1,170	1,205	1,205	1,205	1,015	
	4x8	1-ply	ULP48	LUS48, LUS48Z	JUS48, JUS48-TZ	18 ga	3-9/16	6-1/8	1-3/4	8	16d	6	16d	1,710	1,955	2,005	1,025	1,450	1,525	1,560	890	
		1-ply	UM48	-	-	16 ga	3-9/16	6-1/8	2-1/4	12	16d	6	16d	1,885	1,930	1,930	600	1,625	1,625	1,625	525	
		Rough	UM48R	-	-	16 ga	4	5-15/16	2-1/4	12	16d	6	16d	1,885	1,930	1,930	600	1,625	1,625	1,625	525	
		1-ply	UH48	HUS48	HUS48	14 ga	3-9/16	6-1/8	2-1/4	12	16d	6	16d	1,900	1,960	1,985	1,380	1,495	1,525	1,550	1,195	

### NOTES:

- Nails designated as 16d shall be 16d common nails (0.162" x 3.5", F<sub>y</sub> = 90,000 psi) and 10d shall be 10d common nails (0.148" x 3", F<sub>y</sub> = 90,000 psi).
- Allowable loads are provided for load duration factor (C<sub>D</sub>) of 1.0, 1.15, 1.25 and 1.6.
- Allowable loads labeled "Floor" and "Roof" represent gravity loads.
- These Reference Numbers above are for the purpose of enabling our customers to identify the QuickTie™ alternative to specified product names, but the attributes of the products references (particularly load values) may differ from the QuickTie™ part. Please note that product comparison via Reference Numbers is for general application comparison only. Reference Numbers should not be used as an apples-to-apples substitution tool. Customers are solely responsible for comparing specific load values, fastener schedules, anchoring requirements, material specifications, and other factors when determining the suitability of use of any particular product. QuickTie™ makes no claim, stated or implied, of suitability for purpose or qualification for usage of our products that may be substituted for a specified product. Any specification, submittal, or change to a specified product should be approved in writing by the designer or Engineer of Record (EOR). MiTek® and Simpson Strong-Tie® are registered trademarks of their respective companies, with which QuickTie™ is unaffiliated, and neither of whom endorse or approve use of their product names in this catalog as "reference numbers".

Continued on next page.

## ALLOWABLE LOADS FOR UL, ULP, UM & UH SERIES HANGERS (LB)<sup>1,2,3</sup>

Joist Size			Part No.				QUICKTIE PART ATTRIBUTES														
			QT	Reference No. <sup>4</sup>		Steel Thick.	Hanger Dimensions (in.)			Fasteners				SP/DF-L (SG = 0.50)				HF/SPF (SG = 0.42)			
				Simpson® Hardware (SH)	MiTek® Hardware (MH)		Width, W	Height, H	Depth, D	Header		Joist		Floor	Roof	Roof	Uplift	Floor	Roof	Roof	Uplift
										Qty	Size	Qty	Size								
4x4	1-ply	ULP410	LUS410, LUS410Z, U410	JUS410, JUS410-TZ, SUH410	18 ga	3-9/16	8-1/8	1-3/4	10	16d	8	16d	2,190	2,495	2,575	1,375	1,835	1,940	2,010	1,200	
	1-ply	UM410	-	-	16 ga	3-9/16	8-1/8	2-1/4	18	16d	8	16d	2,320	2,320	2,320	1,065	2,005	2,005	2,005	925	
	Rough	UM410R	U410R	SUH410R	16 ga	4	7-15/16	2-1/4	18	16d	8	16d	2,320	2,320	2,320	1,065	2,005	2,005	2,005	925	
	1-ply	UH410	HUS410	HUS410	14 ga	3-9/16	8-1/8	2-1/4	18	16d	8	16d	2,265	2,375	2,425	1,565	1,780	1,850	1,890	1,365	
4x12	1-ply	ULP412	-	-	18 ga	3-9/16	9-3/16	1-3/4	10	16d	10	16d	2,265	2,265	1,730	1,730	1,825	1,825	1,825	1,510	
	Rough	ULP412R	-	-	18 ga	4	9	1-3/4	10	16d	10	16d	2,265	2,265	1,730	1,730	1,825	1,825	1,825	1,510	
	1-ply	UH412	HUS412	HUS412	14 ga	3-9/16	9-3/16	2-1/4	22	16d	10	16d	3,060	3,210	3,310	1,975	2,355	2,490	2,575	1,720	

## ALLOWABLE LOADS FOR ULP-IF & UH-IF SERIES HANGERS (LB)\*

Joist Size			Part No.				QUICKTIE PART ATTRIBUTES														
			QT	Reference No. <sup>4</sup>		Steel Thick.	Hanger Dimensions (in.)			Fasteners				SP/DF-L (SG = 0.50)				HF/SPF (SG = 0.42)			
				Simpson® Hardware (SH)	MiTek® Hardware (MH)		Width, W	Height, H	Depth, D	Header		Joist		Floor	Roof	Roof	Uplift	Floor	Roof	Roof	Uplift
										Qty	Size	Qty	Size								
2x6	1-ply (IF)	ULP-IF26	LUC26Z	JL26IF-TZ	18 ga	1-5/8	5-3/8	1-3/4	6	16d	4	10d	830	955	1,040	745	715	825	895	640	
(2) 2x6	2-ply (IF)	ULP-IF26-2	-	-		3-1/8	4-5/8														
(3) 2x6	3-ply (IF)	ULP-IF26-3	-	-		4-5/8	3-7/8														
2x8	1-ply (IF)	ULP-IF28	-	JL28IF-TZ	18 ga	1-5/8	7-1/8	1-3/4	8	16d	6	10d	1,110	1,275	1,385	930	955	1,100	1,195	805	
(2) 2x8	2-ply (IF)	ULP-IF28-2	-	-		3-1/8	6-3/8														
(3) 2x8	3-ply (IF)	ULP-IF28-3	-	-		4-5/8	5-5/8														
2x10	1-ply (IF)	ULP-IF210	LUC210Z	JL210IF-TZ	18 ga	1-5/8	9-1/8	1-3/4	10	16d	6	10d	1,385	1,590	1,730	1,115	1,195	1,375	1,490	965	
(2) 2x10	2-ply (IF)	ULP-IF210-2	-	-		3-1/8	8-3/8														
(3) 2x10	3-ply (IF)	ULP-IF210-3	-	-		4-5/8	7-5/8														
(2) 2x6	2-ply (IF)	UH-IF26-2	HUSC26-2	HUS26-2IF	14 ga	3-1/8	4-5/8	2-1/4	12	16d	6	10d	1,740	2,000	2,175	1,170	1,500	1,725	1,875	1,015	
(3) 2x6	3-ply (IF)	UH-IF26-3	HUC26-3	HD26-3IF		4-5/8	3-7/8														
3x6	1-ply (IF)	UH-IF36	HUC36	HD36IF		2-9/16	4-7/8														
4x6	1-ply (IF)	UH-IF46	HUSC46	HUS46IF		3-9/16	4-3/8														
(2) 2x8	2-ply (IF)	UH-IF28-2	HUSC28-2, HUC28-2, HUC28-2Z	HUS28-2IF, HUS28-2IFTZ, HD28-2IF, HD28-2IFTZ	14 ga	3-1/8	6-3/8	2-1/4	14	16d	6	10d	2,030	2,330	2,535	1,170	1,750	2,010	2,185	1,015	
(3) 2x8	3-ply (IF)	UH-IF28-3	-	HD28-3IF	4-5/8	5-5/8															
3x8	1-ply (IF)	UH-IF38	HUC38	HD38IF	2-9/16	6-5/8															
4x8	1-ply (IF)	UH-IF48	HUSC48	HUS48IF	3-9/16	6-1/8															
(2) 2x10	2-ply (IF)	UH-IF210-2	HUSC210-2Z, HUC210-2, HUC210-2Z	HUS210-2IFTZ, HD210-2IF, HD210-2IFTZ	14 ga	3-1/8	8-3/8	2-1/4	18	16d	10	10d	2,400	2,555	2,585	1,950	1,945	2,085	2,180	1,690	
(3) 2x10	3-ply (IF)	UH-IF210-3	HUC210-3, HUC210-3Z	HD210-3IF, HD210-3IFTZ	4-5/8	7-5/8															
3x10	1-ply (IF)	UH-IF310	HUC310	HD310IF	2-9/16	8-5/8															
4x10	1-ply (IF)	UH-IF410	HUSC410	HUS410IF	3-9/16	8-1/8															
(2) 2x12	2-ply	UH-IF212-2	HUSC212-2, HUC212-2	HUS212-2IF, HD212-2IF	14 ga	3-1/8	9-7/16	2-1/4	22	16d	10	10d	3,170	3,335	3,335	1,950	2,540	2,695	2,800	1,690	
(3) 2x12	3-ply	UH-IF212-3	HUC212-3	HD212-3IF		4-5/8	8-11/16														
3x12	1-ply (IF)	UH-IF312	HUC312	HD312IF		2-9/16	9-11/16														
4x12	1-ply (IF)	UH-IF412	HUSC412	HUS412IF		3-9/16	9-3/16														

\*Call QT for code approval information.

### NOTES:

- Nails designated as 16d shall be 16d common nails (0.162" x 3.5", F<sub>y</sub> = 90,000 psi) and 10d shall be 10d common nails (0.148" x 3", F<sub>y</sub> = 90,000 psi).
- Allowable loads are provided for load duration factor (C<sub>D</sub>) of 1.0, 1.15, 1.25 and 1.6.
- Allowable loads labeled "Floor" and "Roof" represent gravity loads.
- These Reference Numbers above are for the purpose of enabling our customers to identify the QuickTie™ alternative to specified product names, but the attributes of the products references (particularly load values) may differ from the QuickTie™ part. Please note that product comparison via Reference Numbers is for general application comparison only. Reference Numbers should not be used as an apples-to-apples substitution tool. Customers are solely responsible for comparing specific load values, fastener schedules, anchoring requirements, material specifications, and other factors when determining the suitability of use of any particular product. QuickTie™ makes no claim, stated or implied, of suitability for purpose or qualification for usage of our products that may be substituted for a specified product. Any specification, submittal, or change to a specified product should be approved in writing by the designer or Engineer of Record (EOR). MiTek® and Simpson Strong-Tie® are registered trademarks of their respective companies, with which QuickTie™ is unaffiliated, and neither of whom endorse or approve use of their product names in this catalog as "reference numbers".

# Truss Hangers

## TRUSS STRAP HANGERS (TSH)

### PRODUCT FEATURES:

TSH (Truss Strap Hangers) are long strap hangers designed for both face mount and top mount applications.

### MATERIAL:

TSH Series – 18 ga, 16 ga, & 14 ga



### COATING:

Galvanized (G185)



### INSTALLATION:

- Use all specified fasteners in schedule to achieve values indicated.

### CODE COMPLIANCE:

TER 1811-03, FL 3557

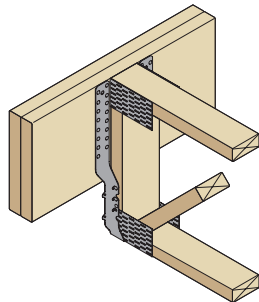
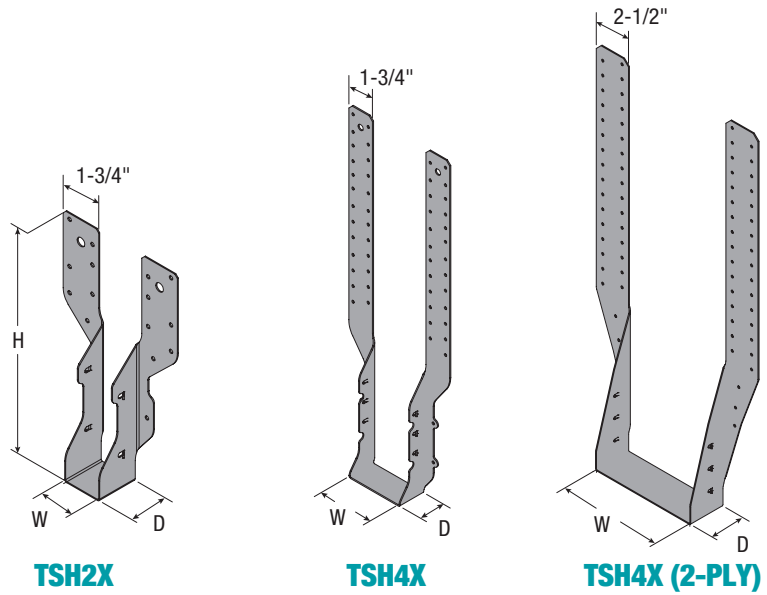

Face Mount

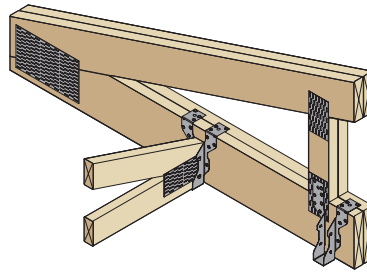

Top Mount

## ALLOWABLE LOADS FOR TSH SERIES HANGERS (TOP MOUNT)<sup>1,2,3,4</sup>

Part No.	Hanger Dimensions (in.)			Steel Thick.	Fasteners					SP (G = 0.55)				DF-L (G = 0.50)				HF/SPF (G = 0.42)			
	Width, W	Height, H	Depth, D		Header		Joist		Floor	Roof	Roof	Uplift	Floor	Roof	Roof	Uplift	Floor	Roof	Roof	Uplift	
					Qty	Size	Qty	Size	1.0	1.15	1.25	1.6	1.0	1.15	1.25	1.6	1.0	1.15	1.25	1.6	
	Face	Top																			
TSH29	1-5/8	9-11/16	1-3/4	18 ga	6	4	10d	4	10d	2,345	2,695	2,875	1,155	2,025	2,325	2,530	1,070	1,505	1,735	1,885	925
TSH213	1-5/8	13-5/16	1-3/4	18 ga	6	4	10d	4	10d	2,435	2,800	2,985	1,000	2,110	2,420	2,635	930	1,580	1,820	1,975	805
TSH218	1-5/8	17-3/16	1-3/4	18 ga	6	4	10d	4	10d	2,520	2,900	3,090	840	2,190	2,515	2,735	785	1,650	1,900	2,065	680
TSH218-2	3-1/8	17-11/16	1-3/4	16 ga	6	4	16d	6	16d	4,625	4,745	4,745	2,835	3,990	4,585	4,665	2,690	2,965	3,410	3,705	2,325
TSH222-2	3-1/8	22-3/16	1-3/4	16 ga	6	4	16d	6	16d	4,625	4,745	4,745	2,835	3,990	4,585	4,665	2,690	2,965	3,410	3,705	2,325
TSH413	3-5/8	13-5/16	1-3/4	18 ga	6	4	16d	4	16d	3,115	3,115	3,115	1,140	2,875	2,875	2,875	1,060	1,315	1,510	1,640	920
TSH418	3-5/8	17-1/2	1-3/4	16 ga	6	4	10d	6	10d	3,800	3,800	3,800	1,785	3,525	3,525	3,525	1,650	2,345	2,555	2,620	1,430
					6	4	16d	6	16d	4,490	4,490	4,490	2,425	3,970	3,970	3,970	2,260	3,000	3,595	3,595	1,950
TSH422	3-5/8	22	1-3/4	16 ga	6	4	16d	6	16d	4,490	4,490	4,490	2,425	3,970	3,970	3,970	2,260	3,000	3,595	3,595	1,950
TSH422-2	7-1/4	22-11/16	2-1/2	14 ga	8	4	16d	6	16d	4,055	4,055	4,055	2,390	3,830	3,830	3,830	2,210	3,315	3,315	3,315	1,910
TSH426	3-5/8	26	1-3/4	14 ga	8	4	16d	6	16d	4,645	4,645	4,645	2,420	4,350	4,350	4,350	2,245	3,375	3,765	3,765	1,955
TSH426-2	7-1/4	26-1/16	2-1/2	14 ga	8	4	16d	6	16d	4,055	4,055	4,055	2,390	3,830	3,830	3,830	2,210	3,315	3,315	3,315	1,910

### NOTES:

- Nails designated as 16d shall be 16d common nails (0.162" x 3.5", F<sub>y</sub> = 90,000 psi) and 10d shall be 10d common nails (0.148" x 3", F<sub>y</sub> = 90,000 psi), unless otherwise noted in the tables.
- Allowable loads are provided for load duration factors (C<sub>D</sub>) of 1.0, 1.15, 1.25 and 1.6.
- Uplift loads have been increased for wind/earthquake load duration (C<sub>D</sub> = 1.6). No further increases permitted. Allowable uplift loads shall be reduced where other load conditions govern.
- Allowable loads labeled "Floor" and "Roof" represent gravity loads.

## ALLOWABLE LOADS FOR TSH SERIES HANGERS (FACE MOUNT)<sup>1,2,3,4</sup>

Part No.	Hanger Dimensions (in.)			Steel Thick.	Fasteners				SP (G = 0.55)				DF-L (G = 0.50)				HF/SPF (G = 0.42)			
	Width, W	Height, H	Depth, D		Header		Joist		Floor	Roof	Roof	Uplift	Floor	Roof	Roof	Uplift	Floor	Roof	Roof	Uplift
					Qty	Size	Qty	Size	1.0	1.15	1.25	1.6	1.0	1.15	1.25	1.6	1.0	1.15	1.25	1.6
TSH29	1-5/8	9-11/16	1-3/4	18 ga	16	10d	4	10d	2,115	2,115	2,115	1,155	1,910	1,910	1,910	1,070	1,455	1,455	1,455	925
TSH213	1-5/8	13-5/16	1-3/4	18 ga	14	10d	4	10d	2,115	2,115	2,115	1,005	1,930	1,930	1,930	930	1,480	1,570	1,570	805
TSH218	1-5/8	17-3/16	1-3/4	18 ga	18	10d	4	10d	2,115	2,115	2,115	850	1,950	1,950	1,950	790	1,505	1,680	1,680	685
TSH218-2	3-1/8	17-11/16	1-3/4	16 ga	22	16d	6	16d	4,100	4,715	5,120	2,835	3,790	4,355	4,735	2,710	2,965	3,410	3,705	2,335
TSH222-2	3-1/8	22-3/16	1-3/4	16 ga	22	16d	6	16d	4,100	4,715	5,120	2,835	3,790	4,355	4,735	2,710	2,965	3,410	3,705	2,335
TSH413	3-5/8	13-5/16	1-3/4	18 ga	14	16d	4	16d	2,160	2,485	2,700	1,145	1,995	2,295	2,495	1,065	1,720	1,980	2,150	925
TSH418	3-5/8	17-1/2	1-3/4	16 ga	22	10d	6	10d	3,275	3,770	4,095	1,950	3,030	3,480	3,785	1,800	2,620	3,010	3,275	1,555
					22	16d	6	16d	4,100	4,715	5,120	2,440	3,790	4,355	4,735	2,255	3,330	3,765	4,095	1,945
TSH422	3-5/8	22	1-3/4	16 ga	22	16d	6	16d	4,100	4,715	5,120	2,440	3,790	4,355	4,735	2,255	3,275	3,765	4,095	1,945
TSH422-2	7-1/4	22-11/16	2-1/2	14 ga	30	16d	6	16d	5,190	5,190	5,190	2,400	4,800	4,800	4,800	2,220	4,150	4,150	4,150	1,920
TSH426	3-5/8	26	2-1/2	14 ga	30	16d	6	16d	4,990	4,990	4,990	2,435	4,555	4,615	4,615	2,260	3,375	3,880	3,990	1,970
TSH426-2	7-1/4	26-1/16	2-1/2	14 ga	38	16d	6	16d	5,190	5,190	5,190	2,400	4,800	4,800	4,800	2,220	4,150	4,150	4,150	1,920

### NOTES:

1. Nails designated as 16d shall be 16d common nails (0.162" x 3.5", F<sub>y</sub> = 90,000 psi) and 10d shall be 10d common nails (0.148" x 3", F<sub>y</sub> = 90,000 psi), unless otherwise noted in the tables.
2. Allowable loads are provided for load duration factors (C<sub>D</sub>) of 1.0, 1.15, 1.25 and 1.6.
3. Uplift loads have been increased for wind/earthquake load duration (C<sub>D</sub> = 1.6). No further increases permitted. Allowable uplift loads shall be reduced where other load conditions govern.
4. Allowable loads labeled "Floor" and "Roof" represent gravity loads.

## TRUSS HIP-JACK HANGERS (THJH)

### PRODUCT FEATURES:

The truss hip/jack hanger is designed to securely attach the hip and jack trusses to the girder truss, its wide seat design allows for the use of both 2-ply and a combination of 1-ply and 2-ply hip and jack trusses.

### MATERIAL:

THJH / THJH-W - 12 ga

### COATING:

Galvanized (G185)



### INSTALLATION:

- Use all specified fasteners in schedule to achieve values indicated.

### CODE COMPLIANCE:

TER 1811-03, FL 3557

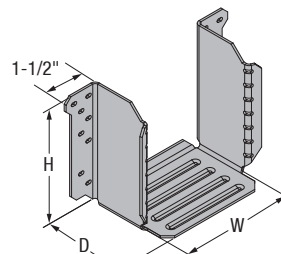

**THJH**

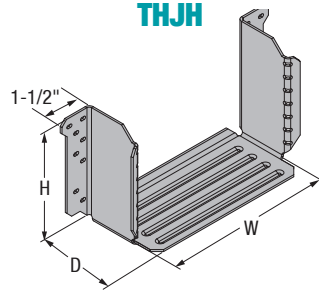

**THJH-W**

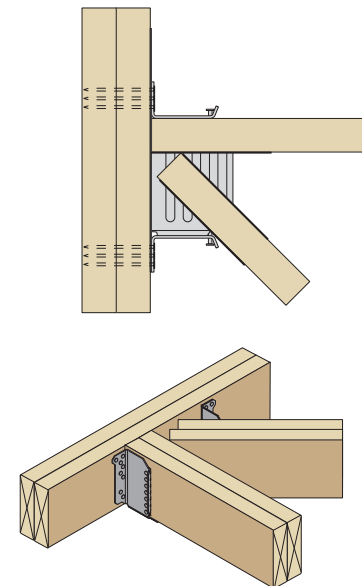

## ALLOWABLE LOADS FOR THJH (LB)<sup>1,2</sup>

Part No.	Joist Size	Hanger Dimensions (in.)			Fasteners				SP/DF-L (0.50)				HF/SPF (0.42)			
		Width, W (in.)	Height, H (in.)	Depth, D (in.)	Headers		Joist		Floor	Roof	Roof	Uplift	Floor	Roof	Roof	Uplift
					Qty	Size	Qty	Size	1.0	1.15	1.25	1.6	1.0	1.15	1.25	1.6
THJH26	2x6	5-1/8	5-3/8	3-1/2	16	10d Common	14	10d x 1-1/2	2,255	2,435	2,435	1,425	1,960	2,120	2,120	1,235
THJH26-W	(2) 2x6	8-1/8	5-3/8	3-1/2	16	10d Common	14	10d Common	2,255	2,590	2,710	1,675	1,950	1,950	1,950	1,455

### NOTES:

1. Allowable loads are the combined loads of the hip and jack members: 65% of the load shall be distributed by the hip member, and 35% of the load shall be distributed by the jack.
2. Allowable loads applicable for hip skewers up to 45 deg.

# Skewed Truss/Joist Hangers

## SKewed U HANGERS (UMS & UHS)

### PRODUCT FEATURES:

The UMSR/L and UHSR/L series are face mount U-hangers, skewed at a 45-degree angle (R - Right or L - Left), used for connecting skewed joist/beam to the headers or trusses.

### MATERIAL:

UMSR/L - 16 ga

UHSR/L - 14 ga

### COATING:

Galvanized (G185)

### INSTALLATION:

- Use all specified fasteners in schedule to achieve values indicated.

### CODE COMPLIANCE:

TER 1811-03; FL 3557

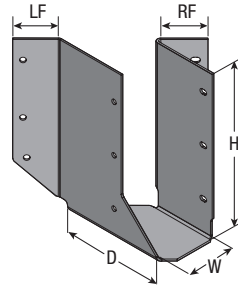

UMSR26

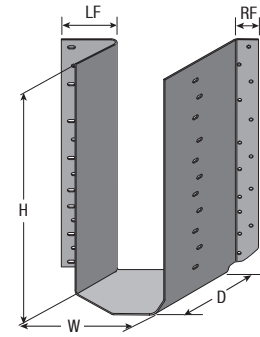

UHSL414

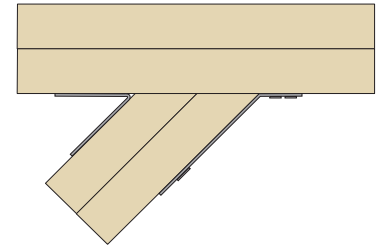
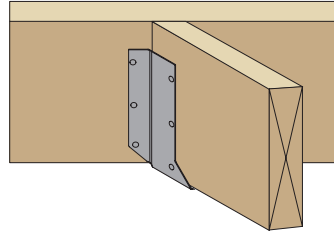

## ALLOWABLE LOADS FOR UMSR/L SERIES<sup>1,2,3</sup>

Part No.	Hanger Dimensions (in.)					Fasteners				SP/DF-L				HF/SPF			
	Width W (in.)	Height H (in.)	Depth D (in.)	LF (in.)	RF (in.)	Header		Joist		Floor	Roof	Roof	Uplift	Floor	Roof	Roof	Uplift
						Qty	Size	Qty	Size	1.0	1.15	1.25	1.6	1.0	1.15	1.25	1.6
UMSR/L24	1-9/16	3-1/2	2	1-1/8	1-1/4	4	16d	4	10d x 1-1/2	625	695	695	395	575	660	660	395
UMSR/L26	1-9/16	5	2	1-1/8	1-5/16	6	16d	6	10d x 1-1/2	935	1,075	1,170	755	865	995	1,080	700
UMSR/L210	1-9/16	8-3/16	2	1-1/8	1-5/16	10	16d	10	10d x 1-1/2	1,555	1,795	1,945	990	1,440	1,660	1,795	990
UMSR/L214	1-9/16	10	2	1-1/8	1-5/16	12	16d	12	16d	1,870	2,155	2,340	2,530	1,730	1,990	2,160	2,340
UMSR/L26-2	3-1/8	4-15/16	2-5/8	1-1/8	2-1/8	8	16d	4	16d	1,250	1,435	1,560	1,030	1,190	1,370	1,490	955
UMSR/L210-2	3-1/8	9-1/4	2-5/8	1-1/8	2-1/8	14	16d	6	16d	2,030	2,335	2,535	1,545	1,935	2,225	2,420	1,430
UMSR/L46	3-9/16	4-1/4	2-5/8	1-7/16	2-3/8	8	16d	4	16d	1,250	1,435	1,560	1,030	1,190	1,370	1,490	955
UMSR/L410	3-9/16	8-1/2	2-5/8	1-1/4	2-3/16	14	16d	6	16d	2,030	2,335	2,535	1,545	1,935	2,225	2,420	1,430
UMSR/L414*	3-9/16	12-1/2	2-5/8	1-7/16	2-3/8	18	16d	8	16d	2,810	3,230	3,510	2,060	2,680	3,080	3,350	1,905
UMSR/L2.56-9	2-9/16	8-13/16	3-3/16	1-1/4	2-3/16	14	16d	2	10d	2,030	2,335	2,535	380	1,935	2,225	2,420	320
UMSR/L2.56-11	2-9/16	11-3/16	3-3/16	1-1/4	2-3/16	16	16d	2	10d	2,420	2,785	3,025	380	4,830	5,555	6,040	4910

### NOTES:

1. Allowable loads are provided for load duration factors ( $C_D$ ) of 1.0, 1.15, 1.25 and 1.6.
  2. Uplift loads have been increased for wind/earthquake load duration ( $C_D = 1.6$ ). No further increases permitted. Allowable uplift loads shall be reduced where other load conditions govern.
  3. Allowable loads labeled "Floor" and "Roof" represent gravity loads.
- \* Install the joist with a miter-cut end and double shear nails.

## ALLOWABLE LOADS FOR UHSR/L SERIES<sup>1,2,3</sup>

Part No.	Hanger Dimensions (in.)					Fasteners				SP/DF-L				HF/SPF			
	Width W (in.)	Height H (in.)	Depth D (in.)	LF (in.)	RF (in.)	Header		Joist		Floor	Roof	Roof	Uplift	Floor	Roof	Roof	Uplift
						Qty	Size	Qty	Size	1.0	1.15	1.25	1.6	1.0	1.15	1.25	1.6
UHSR/L26-2	3-1/8	4-15/16	2-7/16	1-1/8	1-1/4	12	16d	4	16d	1,785	1,965	1,965	955	1,545	1,550	1,550	825
UHSR/L210-2	3-1/8	8-11/16	2-7/16	1-1/8	1-5/16	20	16d	6	16d	2,905	3,340	3,625	1,430	2,510	2,885	2,965	1,235
UHSR/L214-2*	3-1/8	12-11/16	2-7/16	1-1/8	1-5/16	26	16d	8	16d	3,870	4,450	4,835	1,905	3,345	3,845	3,955	1,645
UHSR/L46	3-9/16	4-3/4	2-7/16	1-1/8	1-5/16	12	16d	4	16d	1,785	1,965	1,965	955	1,545	1,550	1,550	825
UHSR/L410	3-9/16	8-1/2	2-7/16	1-1/8	2-1/8	20	16d	6	16d	2,905	3,340	3,625	1,430	2,510	2,885	2,965	1,235
UHSR/L414*	3-9/16	12-1/2	2-7/16	1-1/8	2-1/8	26	16d	8	16d	3,870	4,450	4,835	1,905	3,345	3,845	3,955	1,645

### NOTES:

1. Allowable loads are provided for load duration factors ( $C_D$ ) of 1.0, 1.15, 1.25 and 1.6.
  2. Uplift loads have been increased for wind/earthquake load duration ( $C_D = 1.6$ ). No further increases permitted. Allowable uplift loads shall be reduced where other load conditions govern.
  3. Allowable loads labeled "Floor" and "Roof" represent gravity loads.
- \* Install the joist with a miter-cut end and double shear nails.

## U HANGERS (UMH, UHH & UHD SERIES)

### PRODUCT FEATURES:

U-Hangers are face mount joist hangers used to resist gravity loads and uplift loads due to wind in one-, two- and three-ply joist assemblies in light-frame wood construction.

### MATERIAL:

UMH Series - 16 ga

UHH Series - 14 ga

UHD Series - 12 ga

### COATING:

Galvanized (G185)



### INSTALLATION:

- Use all specified fasteners in schedule to achieve values indicated.
- All U-Hangers have slant nailing. These must be used to achieve published load values. The nails must be driven at an angle (approx. 41°) in the joist and into the header.
- For all Hangers, use 16d common nails (0.162 x 3-1/2") for hanger-to-header attachment.
- Hangers are not allowed to be modified.
- Hangers are not designed for welded applications.

### CODE COMPLIANCE:

TER 1811-03; FL 3557

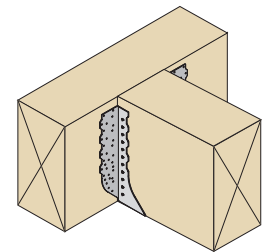
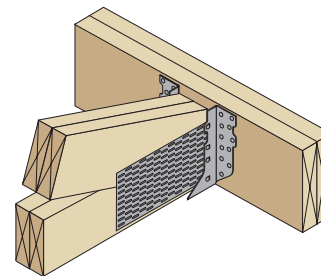
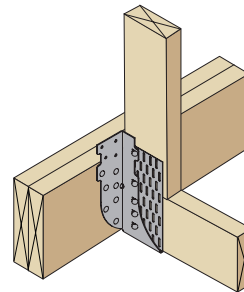
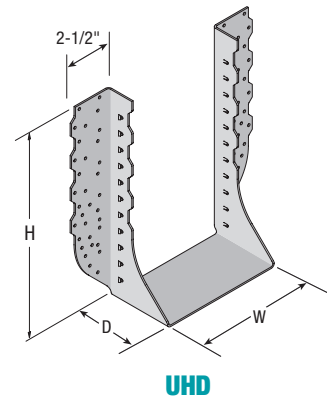
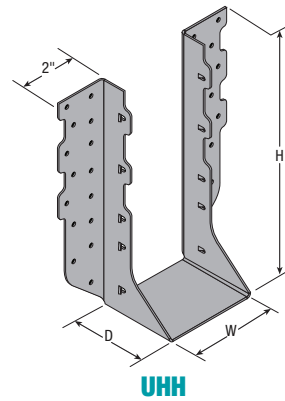
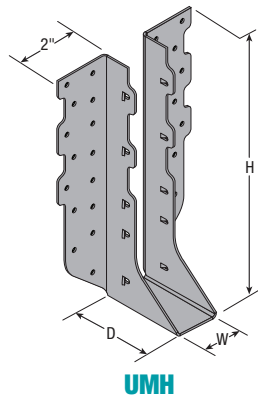

## ALLOWABLE LOADS FOR UMH & UHH SERIES HANGERS (LB)<sup>1,2,3</sup>

Joist Size	Part No.		QUICKTIE PART ATTRIBUTES																					
			Dimensions (in.)			Fasteners		SP (SG = 0.55)				DF-L (SG = 0.50)				HF/SPF (SG = 0.42)								
			Width, W	Height, H	Depth, D	Header		Joist		Floor	Roof	Roof	Uplift	Floor	Roof	Roof	Uplift	Floor	Roof	Roof	Uplift			
QT	Reference No. <sup>4</sup>		Qty	Size	Qty	Size	1.0	1.15	1.25	1.6	1.0	1.15	1.25	1.6	1.0	1.15	1.25	1.6						
UMH (16 ga)	2x6	1-ply	UMH26	HUS26, HUS26Z	HUS26, HUS26-TZ	1-5/8	5-3/8	3	14	16d	8	16d	3,050	3,505	3,610	1,440	2,820	3,245	3,525	1,395	2,440	2,805	3,050	1,215
	2x8	1-ply	UMH28	HUS28, HUS28Z	HUS28, HUS28-TZ	1-5/8	7	3	22	16d	10	16d	4,895	5,125	5,175	2,075	4,780	4,995	5,135	1,950	3,315	3,770	3,895	1,690
	2x10	1-ply	UMH210	HUS210, HUS210Z	HUS210, HUS210-TZ	1-5/8	9	3	30	16d	12	16d	6,740	6,740	6,740	2,710	6,740	6,740	6,740	2,505	4,190	4,735	4,735	2,160
UHH (14 ga)	(2) 2x6	2-ply	UHH26-2	HHUS26-2, HHUS26-2Z	THD26-2	3-5/16	5-3/8	3	14	16d	6	16d	2,905	3,340	3,630	1,745	2,685	3,090	3,360	1,615	2,325	2,675	2,905	1,395
	(2) 2x8	2-ply	UHH28-2	HHUS28-2, HHUS28-2Z	THD28-2, THD28-2TZ	3-5/16	7-1/4	3	22	16d	8	16d	4,950	5,170	5,315	2,535	4,840	5,045	5,180	2,345	3,185	3,360	3,475	2,025
	(2) 2x10	2-ply	UHH210-2	HHUS210-2, HHUS210-2Z	THD210-2, THD210-2TZ	3-5/16	9-3/16	3	30	16d	10	16d	6,995	6,995	6,995	3,320	6,995	6,995	6,995	3,070	4,040	4,040	4,040	2,655
	(3) 2x10	3-ply	UHH210-3	HHUS210-3	THD210-3	4-15/16	8-7/8	3	30	16d	10	16d	5,910	6,800	6,985	3,460	5,470	6,290	6,475	3,215	4,825	5,420	5,420	2,800
	(4) 2x10	4-ply	UHH210-4	HHUS210-4	THD210-4	6-1/8	8-7/8	3	30	16d	10	16d	5,910	6,800	6,985	3,460	5,470	6,290	6,475	3,215	4,825	5,420	5,420	2,800
	4x6	1-ply	UHH46	HHUS46, HHUS46Z	THD46, THD46-TZ	3-5/8	5-1/8	3	14	16d	6	16d	2,905	3,340	3,630	1,745	2,685	3,090	3,360	1,615	2,325	2,675	2,905	1,395
	4x8	1-ply	UHH48	HHUS48, HHUS48Z	THD48, THD48-TZ	3-5/8	7-1/8	3	22	16d	8	16d	4,950	5,170	5,315	2,535	4,840	5,045	5,180	2,345	3,185	3,360	3,475	2,025
	4x10	1-ply	UHH410	HHUS410, HHUS410Z	THD410, THD410-TZ	3-5/8	9	3	30	16d	10	16d	6,995	6,995	6,995	3,320	6,995	6,995	6,995	3,070	4,040	4,040	4,040	2,655
	6x10	1-ply SCL	UHH610	HHUS.55/10	THD610	5-1/2	9	3	30	16d	10	16d	5,910	6,800	6,975	3,460	5,470	6,290	6,630	3,215	4,825	5,535	5,535	2,850
	7x10	1-ply SCL/ Glulam	UHH7210	HHUS.75/10	THD7210	7-1/4	9	3-5/16	30	16d	10	16d	5,910	6,800	6,975	3,460	5,470	6,290	6,630	3,215	4,825	5,535	5,535	2,850

### NOTES:

1. Nails designated as 16d shall be 16d common nails (0.162" x 3.5", F<sub>y</sub>b = 90,000 psi) and 10d shall be 10d common nails (0.148" x 3", F<sub>y</sub>b = 90,000 psi).
2. Allowable loads are provided for load duration factor (C<sub>D</sub>) of 1.0, 1.15, 1.25 and 1.6.
3. Allowable loads labeled "Floor" and "Roof" represent gravity loads.
4. These Reference Numbers above are for the purpose of enabling our customers to identify the QuickTie™ alternative to specified product names, but the attributes of the products references (particularly load values) may differ from the QuickTie™ part. Please note that product comparison via Reference Numbers is for general application comparison only. Reference Numbers should not be used as an apples-to-apples substitution tool. Customers are solely responsible for comparing specific load values, fastener schedules, anchoring requirements, material specifications, and other factors when determining the suitability of use of any particular product. QuickTie™ makes no claim, stated or implied, of suitability for purpose or qualification for usage of our products that may be substituted for a specified product. Any specification, submittal, or change to a specified product should be approved in writing by the designer or Engineer of Record (EOR). MiTek® and Simpson Strong-Tie® are registered trademarks of their respective companies, with which QuickTie™ is unaffiliated, and neither of whom endorse or approve use of their product names in this catalog as "reference numbers".

Continued on next page.

# Truss/Joist Heavy Hangers

## ALLOWABLE LOADS FOR UH SERIES HANGERS (LB)<sup>1,2,3</sup>

Joist Size			Part No.			QUICKTIE PART ATTRIBUTES																			
						Dimensions			Fasteners				SP <sup>1,2</sup>				DF-L <sup>1,2</sup>				HF/SPF <sup>1,2</sup>				
			QT		Reference No. <sup>4</sup>		Width, W (in.)	Height, H (in.)	Depth, D (in.)	Header		Joist		Floor 1.0	Roof 1.15	Roof 1.25	Uplift 1.6	Floor 1.0	Roof 115	Roof 1.25	Uplift 1.6	Floor 1.0	Roof 1.15	Roof 1.25	Uplift 1.6
					Simpson® Hardware (SH)	MiTek® Hardware (MH)				Qty	Size	Qty	Size												
2x6	1-ply	UHD26	HGUS26	THDH26	1-5/8	5-3/8	5	20	16d	8	16d	5,010	5,765	6,265	2,595	4,460	5,130	5,575	2,475	4,060	4,670	5,075	2,170		
	(2) 2x6	2-ply	UHD26-2	HGUS26-2	THDH26-2	3-1/8	4-5/8	4	20	16d	8													16d	
	(3) 2x6	3-ply	UHD26-3	HGUS26-3	THDH26-3	4-5/8	3-7/8	4	20	16d	8													16d	
	(4) 2x6	4-ply	UHD26-4	HGUS26-4	THDH26-4	6-9/16	5-7/16	4	20	16d	8													16d	
2x8	1-ply	UHD28	HGUS28	THDH28	1-5/8	7-1/8	5	36	16d	12	16d	9,375	9,665	9,855	3,550	8,180	8,440	8,610	3,330	6,850	7,505	7,660	2,905		
	(2) 2x8	2-ply	UHD28-2	HGUS28-2	THDH28-2	3-1/8	6-3/8	4	36	16d	12													16d	
	(3) 2x8	3-ply	UHD28-3	HGUS28-3	THDH28-3	4-5/8	5-5/8	4	36	16d	12													16d	
	(4) 2x8	4-ply	UHD28-4	HGUS28-4	THDH28-4	6-9/16	7-3/16	4	36	16d	12													16d	
2x10	1-ply	UHD210	HGUS210	THDH210	1-5/8	9-1/8	5	46	16d	16	16d	12,100	12,100	12,100	4,500	10,505	10,505	10,505	4,180	8,590	9,275	9,275	3,640		
	(2) 2x10	2-ply	UHD210-2	HGUS210-2	THDH210-2	3-1/8	8-3/8	4	46	16d	16													16d	
	(3) 2x10	3-ply	UHD210-3	HGUS210-3	THDH210-3	4-5/8	7-5/8	4	46	16d	16													16d	
	(4) 2x10	4-ply	UHD210-4	HGUS210-4	-	6-9/16	9-3/16	4	46	16d	16													16d	
2x12	3-ply	UHD212-3	HGUS212-3	THDH212-3	4-15/16	8-1/2	4	56	16d	20	16d	13,000	13,000	13,000	5,090	11,570	11,570	11,570	4,655	9,730	10,070	10,070	3,955		
	(4) 2x12	4-ply	UHD212-4	HGUS212-4	-	6-9/16	10-5/8	4	56	16d	20													16d	
	(3) 2x14	3-ply	UHD214-3	HGUS214-3	THDH214-3	4-15/16	12-3/4	4	66	16d	22													16d	
	(4) 2x14	4-ply	UHD214-4	HGUS214-4	-	6-9/16	12-5/8	4	66	16d	22													16d	
3x10	1-ply Glulam	UHD3210	HGUS3.25/10	THDH3210	3-1/4	8-1/4	4	46	16d	16	16d	12,100	12,100	12,100	4,500	10,505	10,505	10,505	4,180	8,590	9,275	9,275	3,640		
	3x12	1-ply Glulam	UHD3212	HGUS3.25/12	THDH3212	3-1/4	9-3/8	4	56	16d	20													16d	
	4x6	1-ply	UHD46	HGUS46	THD46	3-5/8	4-3/8	4	20	16d	8													16d	
	4x8	1-ply	UHD48	HGUS48	THDH48	3-5/8	6-1/8	4	36	16d	12													16d	
4x10	1-ply	UHD410	HGUS410	THDH410	3-5/8	8-1/8	4	46	16d	16	16d	12,100	12,100	12,100	4,500	10,505	10,505	10,505	4,180	8,590	9,275	9,275	3,640		
	(2) 4x10	2-ply	UHD7310	HGUS7.37/10	-	7-3/8	8-9/16	4	46	16d	16													16d	
	(2) 4x12	2-ply	UHD7312	HGUS7.37/12	-	7-3/8	10-5/8	4	56	16d	20													16d	
	4x14	1-ply	UHD414	HGUS414	THDH414	3-5/8	12-9/16	4	66	16d	22													16d	
4x14	(2) 4x14	2-ply	UHD7314	HGUS7.37/14	-	7-3/8	12-9/16	4	66	16d	22	16d	13,895	13,895	13,895	5,385	12,635	12,635	12,635	4,895	10,865	10,865	10,865	4,110	
	6x8	1-ply SCL	UHD558	HGUS5.50/8	-	5-1/22	6-15/16	4	36	16d	12	16d													
	6x10	1-ply SCL	UHD5510	HGUS5.50/10	-	5-1/2	8-15/16	4	46	16d	16	16d													
	6x10G	1-ply Glulam	UHD5210	HGUS5.25/10	-	5-1/4	9-1/16	4	46	16d	16	16d													
6x12	1-ply SCL	UHD5512	HGUS5.50/12	-	5-1/2	10-3/8	4	56	16d	20	16d	13,000	13,000	13,000	5,090	11,570	11,570	11,570	4,655	9,730	10,070	10,070	3,955		
	6x12G	1-ply Glulam	UHD5212	HGUS5.25/12	THDH612	5-1/4	10-1/2	4	56	16d	20													16d	
	6x14	1-ply SCL	UHD5514	HGUS5.50/14	THDH614	5-1/2	12-1/2	4	66	16d	22													16d	
	7x10	1-ply Glulam	UHD6810	HGUS6.88/10	THDH6710	6-7/8	8-13/16	4	46	16d	16													16d	
7x12	1-ply Glulam	UHD6812	HGUS6.88/12	THDH6712	6-7/8	10-13/16	4	56	16d	20	16d	13,000	13,000	13,000	5,090	11,750	11,750	11,750	4,655	9,730	10,070	10,070	3,955		
	7x14	1-ply Glulam	UHD6814	HGUS6.88/14	THDH6714	6-7/8	12-13/16	4	66	16d	22													16d	
	8x10	1-ply SCL/ Glulam	UHD7210	HGUS7.25/10	THDH7210	7-1/4	8-5/8	4	46	16d	16													16d	
	8x12	1-ply SCL/ Glulam	UHD7212	HGUS7.25/12	THDH7212	7-1/4	10-5/8	4	56	16d	20													16d	
8x14	1-ply SCL/ Glulam	UHD7214	HGUS7.25/14	THDH7214	7-1/4	12-7/16	4	66	16d	22	16d	13,895	13,895	13,895	5,385	12,635	12,635	12,635	4,895	10,865	10,865	10,865	4,110		

### NOTES:

- Nails designated as 16d shall be 16d common nails (0.162" x 3.5", F<sub>y</sub> = 90,000 psi) and 10d shall be 10d common nails (0.148" x 3", F<sub>y</sub> = 90,000 psi).
- Allowable loads are provided for load duration factor (C<sub>D</sub>) of 1.0, 1.15, 1.25 and 1.6.
- Allowable loads labeled "Floor" and "Roof" represent gravity loads.
- These Reference Numbers above are for the purpose of enabling our customers to identify the QuickTie™ alternative to specified product names, but the attributes of the products references (particularly load values) may differ from the QuickTie™ part. Please note that product comparison via Reference Numbers is for general application comparison only. Reference Numbers should not be used as an apples-to-apples substitution tool. Customers are solely responsible for comparing specific load values, fastener schedules, anchoring requirements, material specifications, and other factors when determining the suitability of use of any particular product. QuickTie™ makes no claim, stated or implied, of suitability for purpose or qualification for usage of our products that may be substituted for a specified product. Any specification, submittal, or change to a specified product should be approved in writing by the designer or Engineer of Record (EOR). MiTek® and Simpson Strong-Tie® are registered trademarks of their respective companies, with which QuickTie™ is unaffiliated, and neither of whom endorse or approve use of their product names in this catalog as "reference numbers".

## TENSION-COMPRESSION DRAG STRUT CONNECTORS (TCC)

### PRODUCT FEATURES:

The Tension-Compression Drag Strut connector (TCC) is a load-transferring component that connects the girder/beam/truss to the shear walls. It acts as a link between the horizontal members and the vertical shear walls.

### MATERIAL:

TCC16L/R - 7 ga  
TCC21L/R - 3 ga

### COATING:

Spray Painted Primer (gray)

### INSTALLATION:

- Use all specified fasteners in schedule to achieve values indicated.

### CODE COMPLIANCE:

TER 0910-01, FL 3557

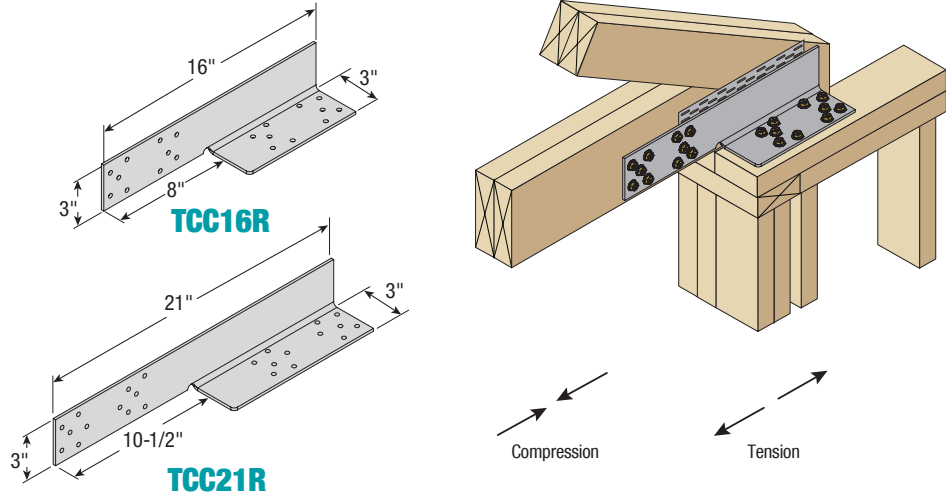

## ALLOWABLE LOADS FOR TCC (LB)<sup>1,2</sup>

Part No.	Length, L (in.)	Fastener Type	Qty	SP (0.55)		DF-L (0.50)		SPF/ HF (0.42)	
				Compression	Tension	Compression	Tension	Compression	Tension
TCC16L	16	SWH3	20	2,600	3,890	2,410	3,605	2,095	3,130
TCC16R									
TCC21L	21	SWH3	24	4,370	5,780	4,370	5,500	3,920	4,720
TCC21R									

### NOTES:

- Allowable loads are provided for load duration factor ( $C_D$ ) of 1.6. No further increase is permitted.
- The structural wood screw, SWH3, is 1/4"x3".

## TRUSS CLIPS (TR)

### PRODUCT FEATURES:

The Truss Clips (TR1, TR2 & TR3) are specifically designed with vertical slots to secure and maintain the accurate alignment between a roof truss and non-load bearing walls.

### MATERIAL:

TR1, TR2 & TR3\* - 18 ga

### COATING:

Galvanized (G185)



### INSTALLATION:

- Use all specified fasteners in schedule to achieve values indicated.
- Nails should be installed in the middle of the slot and not be driven flush with the clips.

### CODE COMPLIANCE:

TER 0910-01, FL 3557

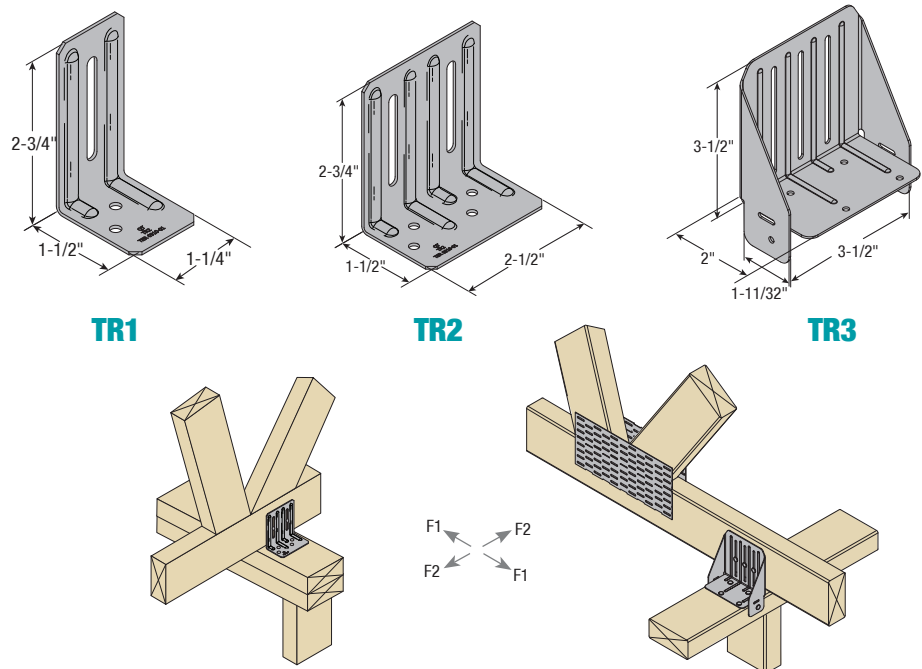

## ALLOWABLE LOADS FOR TR (LB)<sup>1,2</sup>

Part No.	Width, W (in.)	Height, H (in.)	Depth, D (in.)	Fasteners				SOUTHERN PINE (SP) - $C_D = 1.6$							
				Top Plate		Truss/ Rafter (Slots)		No Gap <sup>3</sup>		Gap <sup>3</sup> ≤ 1/4"		1/4" < Gap <sup>3</sup> ≤ 1/2"		Gap = 1-1/4"	
				Qty	Size	Qty	Size	F1	F2	F1	F2	F1	F2	F1	F2
TR1	1-1/4	2-3/4	1-7/8	2	8d (0.131" x 1-1/2")	1	8d (0.131" x 1-1/2")	85	55	65	50	45	40	-	-
TR2	2-1/2	2-3/4	1-7/8	4	8d (0.131" x 1-1/2")	2	8d (0.131" x 1-1/2")	155	195	115	195	80	185	-	-
TR3*	3-1/2	4-3/8	2	4	8d (0.148" x 3")	3	8d (0.148" x 3")	520	305	-	-	-	-	200	305

### NOTES:

- Allowable loads are provided for load duration factor ( $C_D$ ) of 1.6. No further increase is permitted.
- For no gap option, truss or rafter should bear on top plate to achieve the load values indicated.
- TR1 & TR2: To achieve F1 loads, roof truss clips must be present on both sides of the truss.

\*Call QT for code approval information.

# Truss Connectors

## POST-INSTALL GIRDER TIE DOWNS (PHGT & PHHGT)

### PRODUCT FEATURES:

The PHGT series connectors, also known as Post-Install Girder Tie Downs, offer an effective solution for securing multi-ply girder trusses and facilitating the transfer of lateral wind loads to supporting wood and masonry walls.

### MATERIAL:

PHGT2 - 14 ga  
PHHGT3 & PHHGT4 - 12 ga

### COATING:

Galvanized (G185)



### INSTALLATION:

- Use all specified fasteners in schedule to achieve values indicated.

### CODE COMPLIANCE:

TER 0910-01; FL 3557

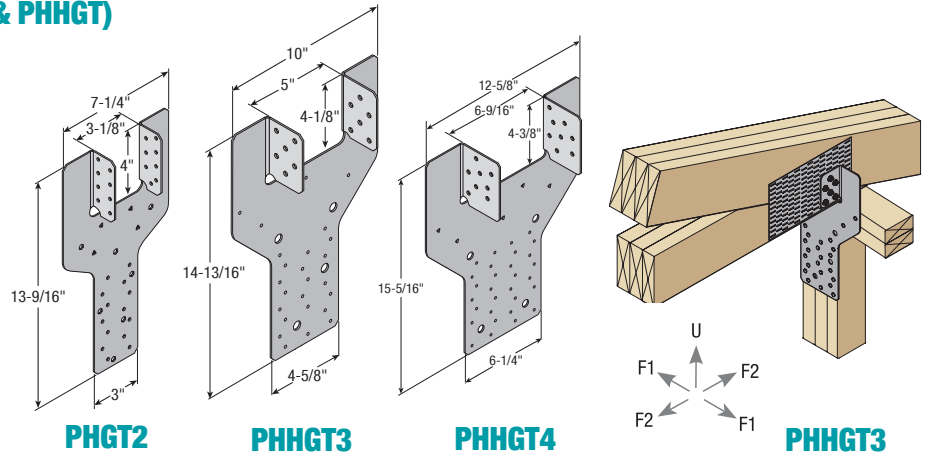

## ALLOWABLE LOADS FOR PHGT (LB)<sup>1, 2, 3</sup>

Part No.	Steel	No. of Piles (Beam/Truss)	Fasteners				SOUTHERN PINE (SP)			DOUGLAS FIR-LARCH (DF-L)			SPRUCE-PINE-FIR (S-P-F)		
			Rafter/Truss		Stud/Top Plate		Uplift (U)	Lateral (F1, Parallel)	Lateral (F2, Perp.)	Uplift (U)	Lateral (F1, Parallel)	Lateral (F2, Perp.)	Uplift (U)	Lateral (F1, Parallel)	Lateral (F2, Perp.)
			Qty	Size	Qty	Size									
PHGT2	14 ga	2	16	10d Common	18	10d common	2,435	980	255	2,435	900	255	2,240	745	210
PHHGT3	12 ga	3	12	SWH3	26	10d common	3,355	1,230	410	3,130	1,230	360	2,710	1,060	280
PHHGT4	12 ga	4	16	SWH3	37	10d common	4,185	2,230	590	3,625	1,825	510	4,185	2,230	510

### NOTES:

- Allowable loads are provided for load duration factor ( $C_D$ ) of 1.6. No further increase is permitted.
- Loading in the F1 direction indicates shear forces parallel to the plane of the wall.
- Loading in the F2 direction indicates shear forces perpendicular to the plane of the wall.

## SLOPED & SKEWED HANGERS (ULPSSH)

### PRODUCT FEATURES:

The ULPSSH is a field-adjustable hanger engineered to support trusses or rafters with varying skew and slope configurations when connecting to beams or other structural members.

### MATERIAL:

ULPSSH - 18 ga

### COATING:

Galvanized (G185)



### INSTALLATION:

- Use all specified fasteners in schedule to achieve values indicated.

### CODE COMPLIANCE:

TER 1811-03; FL 3557.

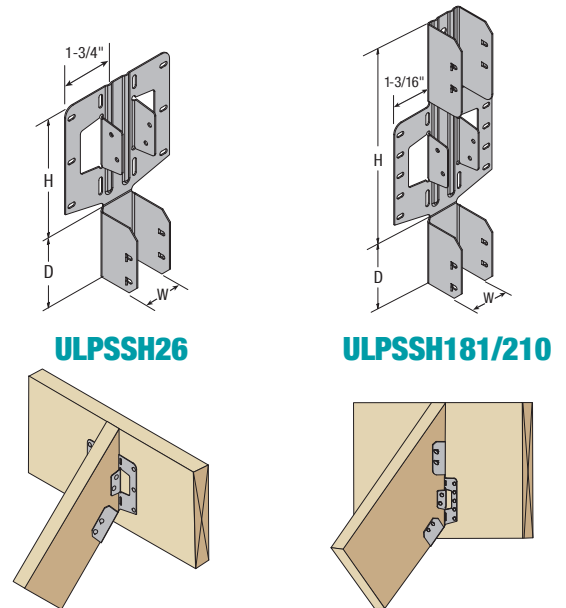

## ALLOWABLE LOADS FOR ULPSSH SERIES

Part No.	Joist Size (in.)	Hanger Dimensions (in.)			Fasteners				SP/DF-L (G = 0.50)				HF/SPF (G = 0.42)			
		Width W (in.)	Height H (in.)	Depth D (in.)	Header		Joist		Floor 1.0	Roof 1.15	Roof 1.25	Uplift 1.6	Floor 1.0	Roof 1.15	Roof 1.25	Uplift 1.6
					Qty	Size	Qty	Size								
<b>Sloped Only Hangers</b>																
ULPSSH26	2 x 6	1-9/16	5-7/16	3	6	10d	9	10d x 1-1/2	680	780	850	855	585	675	730	740
ULPSSH181	1-3/4 x 10	1-13/16	8-3/16	3	10	10d	13	10d x 1-1/2	1,185	1,365	1,480	1,270	1,020	1,175	1,280	1,095
ULPSSH210	2 x 10	1-9/16	8-3/16	3	10	10d	13	10d x 1-1/2	1,185	1,365	1,480	1,270	1,020	1,175	1,280	1,095
<b>Sloped and Skewed Hangers</b>																
ULPSSH26	2 x 6	1-9/16	5-7/16	3	6	10d	9	10d x 1-1/2	690	690	690	530	595	595	595	455
ULPSSH181	1-3/4 x 10	1-13/16	8-3/16	3	10	10d	13	10d x 1-1/2	635	635	635	625	545	545	545	540
ULPSSH210	2 x 10	1-9/16	8-3/16	3	10	10d	13	10d x 1-1/2	635	635	635	625	545	545	545	540

### NOTES:

- Uplift loads have been increased for wind load duration ( $C_D$ ) = 1.6. No further increase permitted.
- Nails designated as 10d shall be 10d common nails (0.148" x 3",  $F_y = 90,000$  psi) and 10d x 1-1/2 shall be 0.148" x 1.5" ( $F_y = 90,000$  psi).

## CORNER HIP PLATES (CHP)

### PRODUCT FEATURES:

Corner Hip Plates (CHP) are used to secure trusses or rafters to double top plates, effectively resisting uplift forces.

### MATERIAL:

CHP1.81, CHP2 & CHP4 - 18 ga

### COATING:

Galvanized (G185)



### INSTALLATION:

- Use all specified fasteners in schedule to achieve the values indicated.

### CODE COMPLIANCE:

Call QT for code approval information.

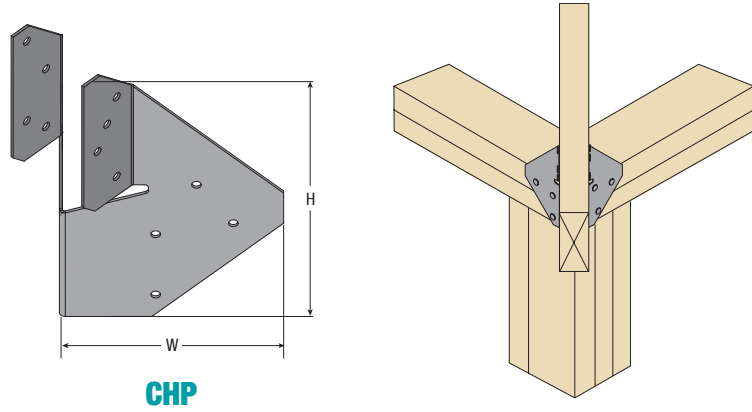

**CHP**

## ALLOWABLE LOADS FOR CHP (LB)

Part No.	H	W	Member Size	Fasteners				SP/D-F-L		HF/S-P-F	
				Trusses/Rafters		Top Plate		Uplift	F1	Uplift	F1
				Type	Qty	Type	Qty				
CHP1.81	6	3-9/16	1-3/4	10d x 1-1/2	6	10d x 1-1/2	6	615	205	710	265
CHP2			2x								
CHP4	6-5/8	4-7/8	4x	10d common	8	10d common	8	1,100	410	950	355

### NOTES:

1. Allowable loads are provided for load duration factor ( $C_D$ ) of 1.6. No further increase is permitted.

## JACK TRUSS CONNECTOR (JTC)

### PRODUCT FEATURES:

JTCs, or Jack Truss Connectors, are designed to be easily skewable, allowing them to be field-bent to various angles for a wide range of applications.

### MATERIAL:

JTC - 16 ga

### COATING:

Galvanized (G185)



### INSTALLATION:

- Use all specified fasteners in schedule to achieve load values indicated.

### CODE COMPLIANCE:

Call QT for code approval information

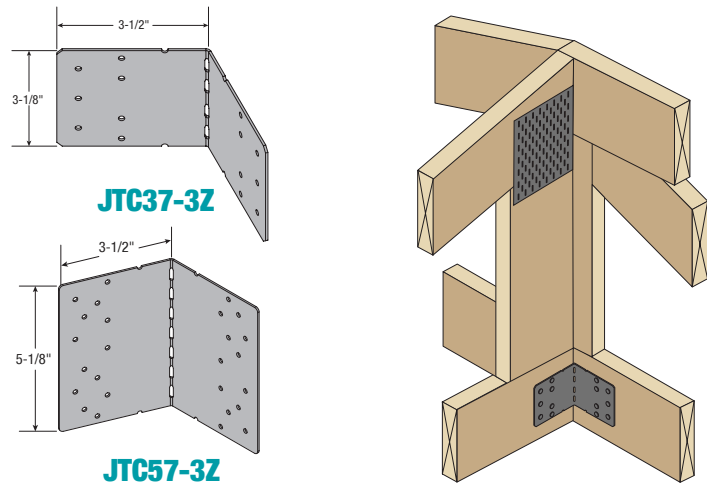

**JTC37-3Z**

**JTC57-3Z**

## ALLOWABLE LOADS FOR JTC (LB)<sup>1,2</sup>

Part No.	W (in.)	H (in.)	Fastener Type	Fastener Qty		Allowable Loads (lb)					
				Header	Joist	SP/DF-L (SG = 0.50)			HF/SPF (SG = 0.42)		
						0°	1° - 60°	60° - 68°	0°	1° - 60°	60° - 68°
JTC37-3Z	7	3-1/8	8d x 1-1/2	7	7	515	430	375	440	365	325
JTC57-3Z	7	5-1/8	8d x 1-1/2	13	13	865	815	785	745	700	675

### NOTES:

1. Allowable loads are applicable for both gravity and uplift forces
2. For back-to-back installation, the tabulated values are multiplied by a factor of 0.70.

# Wood Screws

## STRUCTURAL WOOD SCREWS

### PRODUCT FEATURES:

The QuickTie™ Structural Wood Screws are self-drilling screws used for interior and exterior wood framing applications. These are 1/4" diameter screws, available in four different head configurations [Hex Head (SWH), Flat Head (SWF), Fillister Head (SWL) and Truss/Stud (SWT)] and various lengths.

SWH#9 and SWH#10 are wood screws designed to replace nails used in QT connectors and hangers, providing improved allowable gravity and uplift load values. The SWH#9 replaces 10d nails, and the SWH#10 replaces 16d nails.

Woods screws are installed without lead holes, as prescribed in NDS.

### MATERIALS:

Carbon Steel, Heat Treated

### COATING:

Dorken Coating, Truss screw has an additional teal (SWT6) or black (SWT45) top coat

### CODE COMPLIANCE:

TER 0910-01, FL 3557

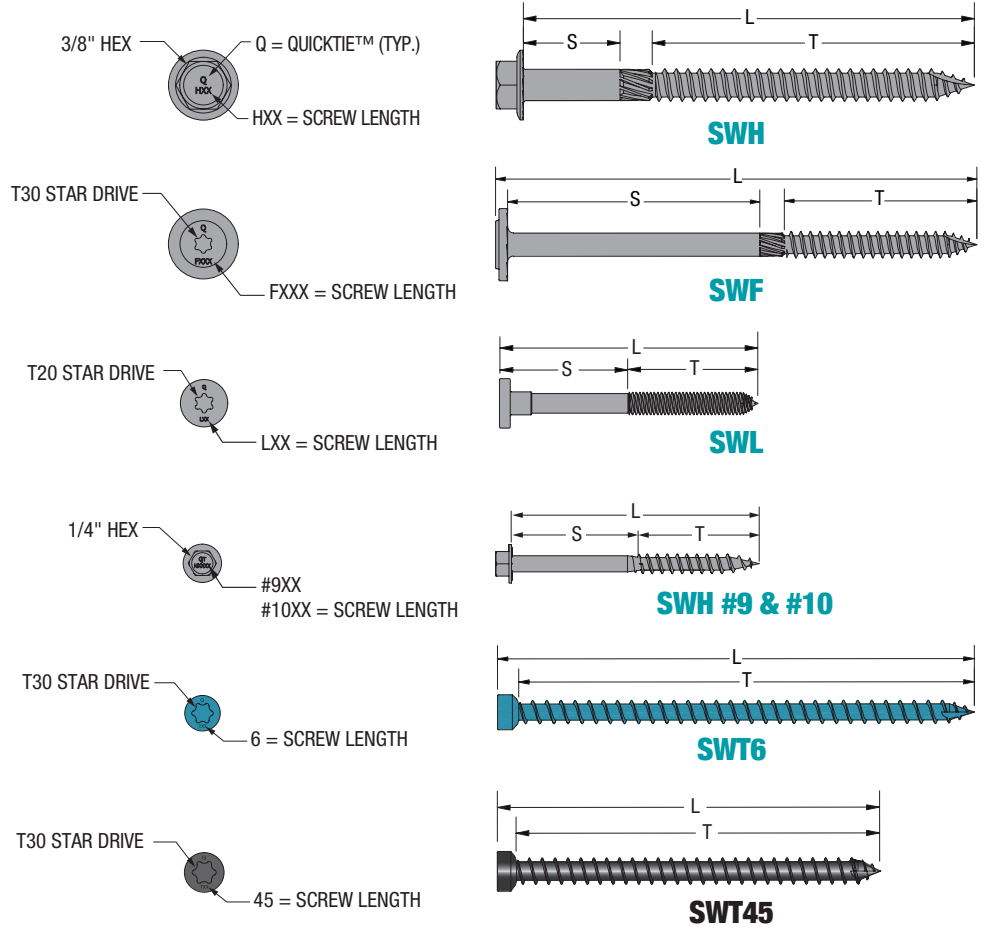

## WOOD SCREWS SPECIFICATIONS<sup>1,2</sup>

FASTENER TYPE	PART NUMBER	PART DESCRIPTION	LENGTHS (in.)			DIAMETER (in.)				Nominal Bending Yield, $F_{yb}$ (psi)	ALLOWABLE FASTENER	
			TOTAL	SHANK, S	THREAD, T	HEAD	MAJOR	SHANK	MINOR		Tension	Shear
SWH (HEX HEAD)	SWH15	1/4" x 1-1/2"	1-1/2"	1/4"	1-1/4"	0.540	0.254	0.241	0.185	168,000	1,435	985
	SWH2	1/4" x 2"	2"	1/4"	1-3/4"							
	SWH25	1/4" x 2-1/2"	2-1/2"	1/4"	2-1/4"							
	SWH3	1/4" x 3"	3"	3/4"								
	SWH35	1/4" x 3-1/2"	3-1/2"	3/4"	2-3/4"							
	SWH45	1/4" x 4-1/2"	4-1/2"	1-1/4"	3-1/4"							
	SWH5	1/4" x 5"	5"	1-3/4"								
	SWH6	1/4" x 6"	6"	1-3/4"	4-1/4"							
SWH8	1/4" x 8"	8"	4-3/4"	3-1/4"								
SWH #9 & #10* (HEX HEAD)	SWH915	#9 x 1-1/2"	1-1/2"	5/16"	1-13/64"	0.378	0.177	0.132	0.113	190,000	555	445
	SWH925	#9 x 2-1/2"	2-1/2"	1-5/16"								
	SWH1015	#10 x 1-1/2"	1-1/2"	3/8"			0.200	0.161	0.126			
	SWH1025	#10 x 2-1/2"	2-1/2"	1-3/8"								
SWF (FLAT HEAD)	SWF278	1/4" x 2-7/8"	2-7/8"	5/8"	2-1/4"	0.750	0.280	0.241	0.185	175,000	1,645	1,145
	SWF338	1/4" x 3-3/8"	3-3/8"	1-1/8"								
	SWF358	1/4" x 3-5/8"	3-5/8"	1-3/8"								
	SWF45	1/4" x 4-1/2"	4-1/2"	2-1/4"								
	SWF5	1/4" x 5"	5"	2-3/4"								
	SWF6	1/4" x 6"	6"	3-3/4"								
	SWF638	1/4" x 6-3/8"	6-3/8"	4-1/8"								
	SWF634	1/4" x 6-3/4"	6-3/4"	4-1/2"								
SWF8	1/4" x 8"	8"	5-3/4"									
SWL (FILLISTER HEAD)	SWL15	9 x 1-3/8"	1-3/8"	1/4"	1-1/8"	0.365	0.170	-	0.109	160,000	465	385
	SWL3	9 x 2-7/8"	2-7/8"	1-3/8"	1-1/2"							
SWT (TRUSS/STUD)	SWT45	0.15" x 4-1/2"	4-1/2"	-	4-5/16"	0.330	0.235	-	0.160	190,000	1,160	820
	SWT6	0.15" x 6"	6"	-	5-13/16"							

### NOTES:

1. SWF and SWT fastener length is measured from the top side of the head to the tip. SWH and SWL fastener length is measured from the underside of the head to the tip.

2. Thread length excludes the knurl on SWH and SWF. SWL and SWT do not contain a knurl.

\*Call QT for code approval information.

## REFERENCE LATERAL DESIGN VALUES (Z) FOR CONNECTIONS IN SAWN LUMBER (LB)<sup>1,2,3</sup>

Fastener Type	Part Number	Screw Length, L (in.)	Thread Length, T (in.)	Minimum Side Member Thickness (in.)	Minimum Main Member Penetration <sup>4</sup> (in.)	Wood Species (Specific Gravity)	
						SP (0.55) / DF-L (0.50)	
						Z <sub>  </sub>	Z <sub>⊥</sub>
SWH	SWH3	3	2-1/4	1.50	1.50	420	330
	SWH35	3-1/2	2-3/4				
	SWH45	4-1/2	3-1/4				
	SWH5	5	3-1/4	1.50	3.50	500	330
	SWH6	6	4-1/4				
SWH8	8	3-1/4					
SWF	SWF278	2-7/8	2-1/4	1.50	1.20	425	330
	SWF338	3-3/8	2-1/4				
	SWF358	3-5/8	2-1/4				
	SWF45	4-1/2	2-1/4	1.50	1.50	420	330
	SWF5	5	2-1/4				
	SWF6	6	2-1/4				
	SWF638	6-3/8	2-1/4				
	SWF634	6-3/4	2-1/4				
SWF8	8	2-1/4					
SWT	SWT45	4-1/2	4-5/16	1.50	3.00	295 <sup>(5)</sup>	
	SWT6	6	5-13/16				
SWL	SWL3	2-7/8	1-1/2	1.50	1.38	240	85

### NOTES:

- Reference lateral design values apply to two-member single shear connections where both members are of the same specific gravity and the fastener is oriented perpendicular to grain, unless otherwise noted.
- Tabulated lateral design values (Z) shall be adjusted by all applicable adjustment factors per NDS Table 11.3.1.
- Z<sub>⊥</sub> = Lateral Design Values Perpendicular to Grain, Z<sub>||</sub> = Lateral Design Values Parallel to Grain.
- Fastener main member penetration is the length embedded in the main member, including the tip.
- Value is applicable where the main member is loaded parallel to grain and the side member is loaded perpendicular to grain.

## REFERENCE WITHDRAWAL DESIGN VALUES (LB/IN) AND MAXIMUM WITHDRAWAL DESIGN VALUES (LB)<sup>1,2</sup>

Fastener Type	Part Number	Screw Length, L (in.)	Thread Length, T (in.)	Wood Species (Specific Gravity)		
				SP (0.55) / DF-L (0.50)		
				Per Inch Thread Penetration (Includes Tip) (lb/in.)	Per Inch Thread Penetration (Excludes Tip) (lb/in.)	Max. Withdrawal Value <sup>1,2</sup> (lb)
SWH	SWH15	1-1/2	1-1/4	310	390	405
	SWH2	2	1-3/4			600
	SWH25	2-1/2	2-1/4			795
	SWH3	3	2-1/4			990
	SWH35	3-1/2	2-3/4			1180
	SWH45	4-1/2	3-1/4			1435
	SWH5	5	3-1/4			1180
	SWH6	6	4-1/4			
SWH #9 & #10	SWH915	1-1/2	1-13/64	255	255	305
	SWH925	2-1/2	1-13/64			
	SWH1015	1-1/2	1-13/64			
	SWH1025	2-1/2	1-13/64			
SWF	SWF278	2-7/8	2-1/4	340	480	935
	SWF338	3-3/8	2-1/4			
	SWF358	3-5/8	2-1/4			
	SWF45	4-1/2	2-1/4			
	SWF5	5	2-1/4			
	SWF6	6	2-1/4			
	SWF638	6-3/8	2-1/4			
	SWF634	6-3/4	2-1/4			
SWT	SWT45	4-1/2	4-5/16	335	-	940
	SWT6	6	5-13/16			940
SWL	SWL15	1-1/8	1-1/2	225	-	250
	SWL3	2-7/8	1-1/2			335

### NOTES:

- Tabulated withdrawal values (W) shall be adjusted by all applicable adjustment factors per NDS Table 11.3.1.
- Minimum fastener penetration into main member of 1" is required. Fastener penetration is the threaded length embedded in the main member.

## REFERENCE LATERAL DESIGN VALUES (Z) FOR CONNECTIONS WITH STEEL SIDE PLATE (LB)<sup>1,2,3</sup>

Fastener Name	Minimum Side Member Thickness <sup>4</sup> (in.)	Minimum Main Member Penetration <sup>3</sup>	Wood Species (Specific Gravity)	
			SP (0.55) / DF-L (0.50)	
			Z <sub>  </sub>	Z <sub>⊥</sub>
SWH15	0.075 (14 ga)	1.425	260	260
	0.105 (12 ga)	1.395	260	260
	0.120 (11 ga)	1.380	260	260
	0.134 (10 ga)	1.366	260	260
	0.179 (7 ga)	1.321	260	260
	0.239 (3 ga)	1.261	260	260
SWH2	0.075 (14 ga)	1.925	330	330
	0.105 (12 ga)	1.895	330	330
	0.120 (11 ga)	1.880	330	330
	0.134 (10 ga)	1.866	330	330
	0.179 (7 ga)	1.821	330	330
	0.239 (3 ga)	1.761	330	330
SWH25	0.075 (14 ga)	2.425	400	400
	0.105 (12 ga)	2.395	400	400
	0.120 (11 ga)	2.380	400	400
	0.134 (10 ga)	2.366	430	430
	0.179 (7 ga)	2.321	430	430
	0.239 (3 ga)	2.261		
SWH3 SWH35 SWH45	0.075 (14 ga)	2.925	710	595
	0.105 (12 ga)	2.895	730	615
	0.120 (11 ga)	2.880	740	625
	0.134 (10 ga)	2.866	750	630
	0.179 (7 ga)	2.821	780	660
	0.239 (3 ga)	2.761	780	660
SWH5 SWH6 SWH8	0.075 (14 ga)	4.925	825	820
	0.105 (12 ga)	4.895	790	815
	0.120 (11 ga)	4.880	775	810
	0.134 (10 ga)	4.866	760	810
	0.179 (7 ga)	4.821	710	800
	0.239 (3 ga)	4.761	710	800
SWH915	0.075 (20 ga)	1.465	205	205
SWH925		1.465	250	270
SWH1015	0.075 (20 ga)	1.465	225	220
SWH1025		1.465	270	290
SWL15	0.048 (18 ga)	1.330	330	310
SWL3				

### NOTES:

- Tabulated lateral design values (Z) shall be adjusted by all applicable adjustment factors per NDS Table 11.3.1.
- Z<sub>⊥</sub> = Lateral Design Values Perpendicular to Grain, Z<sub>||</sub> = Lateral Design Values Parallel to Grain.
- Fastener main member penetration is the length embedded in the main member, including the tip.
- Tabulated allowable shear values apply to assemblies having a wood main member with a specific gravity of at least 0.50 and a steel side plate with an ultimate tensile strength of at least 65 ksi.

## REFERENCE HEAD PULL-THROUGH DESIGN VALUES (LB)<sup>1,2</sup>

Fastener Type	Head Diameter (in.)	Wood Species (Specific Gravity)
		SP (0.55) / DF-L (0.50)
SWH	0.540	790
SWF	0.750	1210
SWL	0.365	430

### NOTES:

- Tabulated pull-through values (P) shall be adjusted by all applicable adjustment factors per NDS Table 11.3.1.
- Pull-through design values apply to connections having a minimum wood side member thickness of at least 1.5".

# Truss to Plate Connections using QuickTie™ Truss Screws (SWT)

## ALLOWABLE UPLIFT AND LATERAL LOADS FOR TRUSS SCREW IN TOP PLATE TO TRUSS/RAFTER/JOIST CONNECTIONS<sup>1,2,3</sup>

Fastener Designation	Min. Penetration into Truss/Rafter/Joist (in.)	Top Plate	Fastener Angle to Vertical	Allowable Loads (lb)		
				SP (SG = 0.55)		
				Uplift	F1	F2
SWT6	2-1/2	Double	0°	940	530	500
			22.5°	940	360	705

**NOTES:**

1. Wood truss, rafter, or floor joist members shall be a minimum of 2" nominal thickness.
2. Includes 1.6 duration of load increase for wind and seismic. No further duration of load increases permitted. Reduce design values for other load durations as applicable.
3. Install fastener at an upward angle from the vertical of 20° to 25° (22.5° is optimal) or 0°. For installation between 20° and 25°, design values for 22.5° may be used.

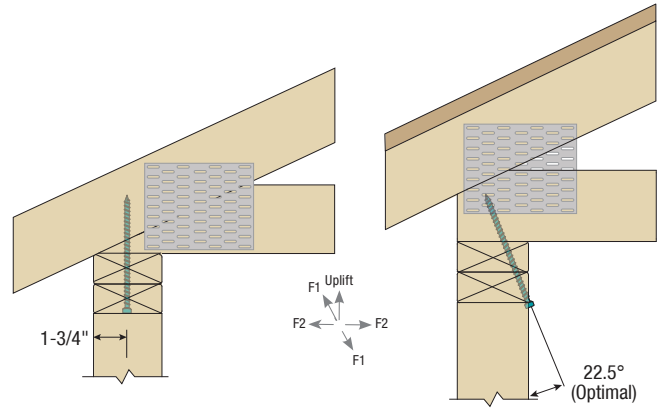

## ALLOWABLE UPLIFT AND LATERAL LOADS FOR TRUSS SCREW IN TOP PLATE TO GABLE END TRUSS CONNECTIONS<sup>1,2,3</sup>

Fastener Designation	Min. Penetration into Gable End Truss (in.)	Top Plate	Fastener Angle to Vertical	Allowable Loads (lb)		
				SP (SG = 0.55)		
				Uplift	F1	F2
SWT6	3	Double	0°	940	650	565

**NOTES:**

1. Gable end truss bottom chord shall be a minimum of 2" nominal thickness. Design of truss, rafter, or floor joist is by others.
2. Includes 1.6 duration of load increase for wind and seismic. No further duration of load increases permitted. Reduce design values for other load durations as applicable.
3. Install fastener at an upward angle from the vertical of 0 degrees. Fastener edge distance is 3/4".

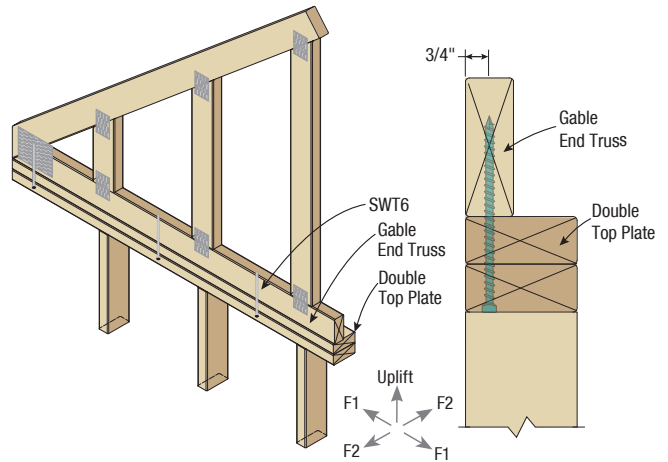

## ALLOWABLE UPLIFT LOAD FOR TRUSS SCREW IN VALLEY TRUSS CONNECTION<sup>1,2,3,4</sup>

Fastener Designation	Min. Penetration into Main Member (in.)	Fastener Angle to Vertical	Allowable Uplift Load (lb)
			SP (SG = 0.55)
SWT6	2	0°	675

**NOTES:**

1. Install fastener at an angle from the vertical of 0°, with the fastener centered on the valley truss bottom chord members.
2. Truss members shall be a minimum of 2" nominal thickness. Sheathing may be installed between the truss members.
3. Lower truss member may have a maximum 6:12 pitch. A minimum 2" penetration into the main member is required.
4. Includes 1.6 duration of load increase for wind and seismic. No further duration of load increases permitted. Reduce design values for other load durations as applicable.

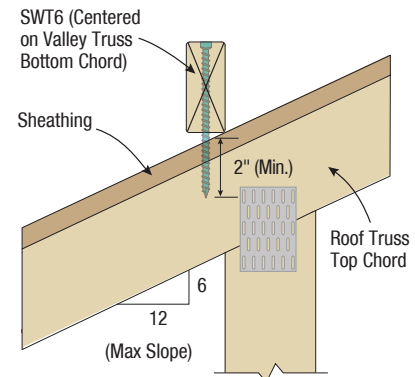

## ALLOWABLE UPLIFT AND LATERAL LOADS FOR STUD TO PLATE CONNECTIONS, FASTENER INSTALLED IN NARROW & WIDE FACES

Fastener Designation <sup>1</sup>	Nominal Plate Thickness <sup>2</sup>	Allowable Loads <sup>3,4</sup> (lb)	
		SP (SG = 0.55)	
		Uplift	Lateral (F2) <sup>5</sup>
SWT45	2x	565	405

**NOTES:**

1. Fastener shall be installed at an angle between 20-30 degrees. 22 degrees is optimal.
2. Dimensional lumber members shall be a minimum of 2" nominal thickness.
3. Includes 1.6 duration of load increase for wind and seismic. No further duration of load increases permitted. Reduce design values for other load durations as applicable.
4. Limit one fastener installed in the narrow face of each stud.
5. The lateral load direction (F2) is perpendicular to the face of the wall.

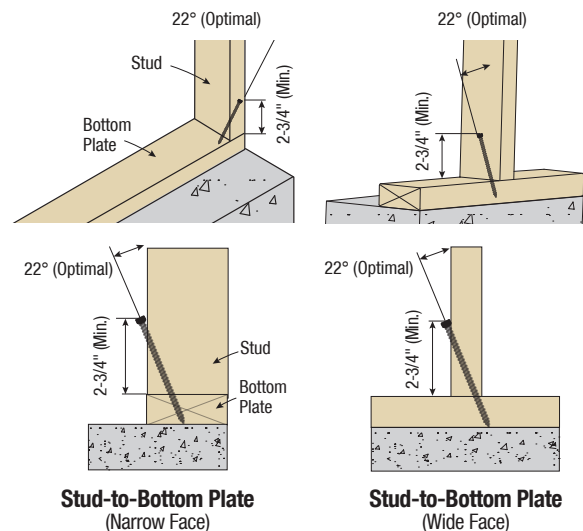

# Deck Ledger to Stud Attachment Using Hex Head Screws (SWH)

SCREWS

## GYPSUM WALLBOARD (GWB) INTERLAYERS

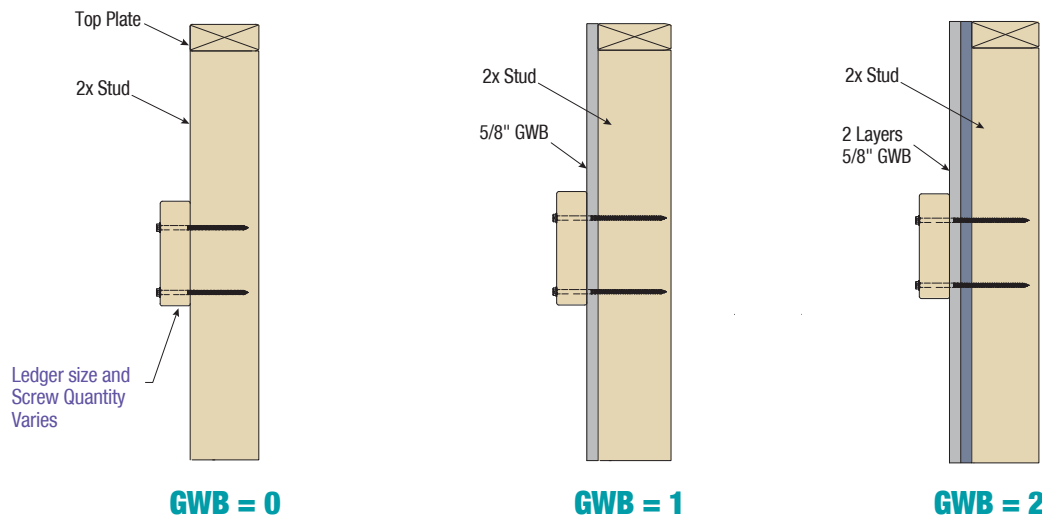

## MINIMUM SCREW EDGE DISTANCE, END DISTANCE AND SPACING FOR DIFFERENT LEDGER SIZE

(Same for Ledger with GWB Interlayers)

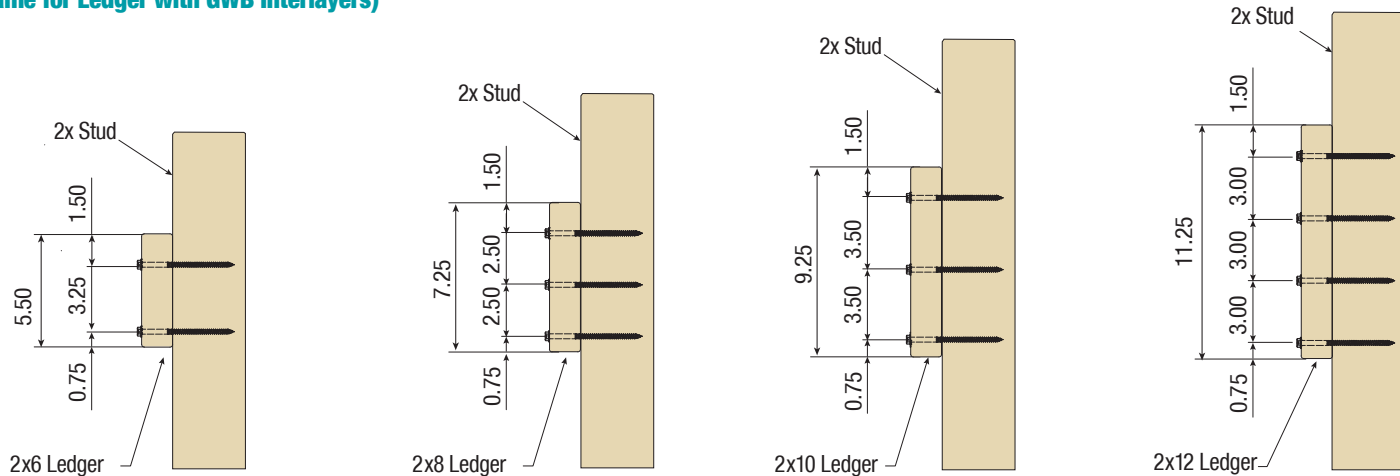

## LATERAL DESIGN VALUES FOR LEDGER TO STUD ATTACHMENT

Ledger Species	Layers of GWB <sup>3</sup>	Stud Species	Fastener Designation	Nominal Fastener Length <sup>6</sup>	Minimum Penetration into Main Member (in)	Allowable Load per Stud Connection(lb) <sup>2,3,4</sup>			
						Ledger Size <sup>1</sup>			
						2x6	2x8	2x10	2x12
SP (0.55)	0	SP (0.55)	SWH3	3	1-1/2	490	735	735	975
			SWH35	≥ 3-1/2	2	510	770	770	1,025
		DF-L (0.50)	SWH3	3	1-1/2	440	660	660	880
			SWH35	≥ 3-1/2	2	490	735	735	980
	1	SP (0.55)	SWH3	3	1-1/2	365	550	550	730
			SWH35	≥ 3-1/2	2	430	670	670	890
		DF-L (0.50)	SWH35	≥ 3-1/2	1-3/8	310	460	460	615
			SWH45	≥ 4	1-3/8	280	415	415	555
	2	SP (0.55)	SWH35	≥ 4	1-7/8	300	450	450	600
			SWH45	≥ 4	1-7/8	230	345	345	465
		DF-L (0.50)	SWH35	≥ 4	1-3/8	285	430	430	570
			SWH45	≥ 4	1-3/8	230	345	345	465
2	SP (0.55)	SWH45	≥ 4	1-1/4	205	305	305	405	
		SWH45	≥ 4	1-1/4	185	275	275	365	
	DF-L (0.50)	SWH45	≥ 4	1-1/4	185	275	275	365	
		SWH5	≥ 5	2-1/4	200	300	300	400	
SPF (0.42)	SWH45	≥ 4	1-1/4	155	230	230	310		
	SWH5	≥ 5	2-1/4	195	295	295	390		

# Deck Ledger to Stud Attachment Using Hex Head Screws (SWH)

Ledger Species	Layers of GWB <sup>5</sup>	Stud Species	Fastener Designation	Nominal Fastener Length <sup>6</sup>	Minimum Penetration into Main Member (in)	Allowable Load per Stud Connection(lb) <sup>2,3,4</sup>			
						Ledger Size <sup>1</sup>			
						2x6	2x8	2x10	2x12
DF-L (0.50)	0	SP (0.55)	SWH3	3	1-1/2	465	695	695	925
			SWH35	≥ 3-1/2	2	475	710	710	950
		DF-L (0.50)	SWH3	3	1-1/2	425	640	640	850
			SWH35	≥ 3-1/2	2	460	690	690	920
		SPF (0.42)	SWH3	3	1-1/2	355	535	535	710
			SWH35	≥ 3-1/2	2	430	645	645	860
	1	DF-L (0.50)	SWH35	≥ 3-1/2	1-3/8	300	450	450	600
			SWH35	3-1/2	1-3/8	275	410	410	545
			SWH45	≥ 4	1-7/8	295	440	440	585
		SPF (0.42)	SWH35	3-1/2	1-3/8	230	340	340	455
			SWH45	≥ 4	1-7/8	280	420	420	560
		2	SP (0.55)	SWH45	≥ 4	1-1/4	200	300	300
	DF-L (0.50)		SWH45	4	1-1/4	180	275	275	365
			SWH5	≥ 5	2-1/4	200	295	295	395
	SPF (0.42)		SWH45	4	1-1/4	155	230	230	305
	SPF (0.42)	0	SP (0.55)	SWH3	≥ 3	1-1/2	390	580	580
DF-L (0.50)			SWH3	3	1-1/2	360	540	540	720
			SWH35	≥ 3-1/2	2	380	565	565	755
SPF (0.42)			SWH3	3	1-1/2	310	465	465	620
		SWH35	≥ 3-1/2	2	355	535	535	715	
1		SP (0.55)	SWH35	≥ 3-1/2	1-3/8	270	405	405	540
		DF-L (0.50)	SWH35	3-1/2	1-3/8	255	385	385	510
			SWH45	≥ 4	1-7/8	265	400	400	535
		SPF (0.42)	SWH35	3-1/2	1-3/8	220	330	330	440
SWH45			≥ 4	1-7/8	260	385	385	515	
2		SP (0.55)	SWH45	≥ 4	1-1/4	195	295	295	390
		DF-L (0.50)	SWH45	4	1-1/4	180	265	265	355
			SWH5	≥ 5	2-1/4	195	290	290	385
		SPF (0.42)	SWH45	4	1-1/4	150	225	225	300
SWH5		≥ 5	2-1/4	190	280	280	375		

**NOTES:**

- Two fasteners are required for 2x6 ledger connections. Three fasteners are required for 2x8 and 2x10 ledger connections. Four fasteners are required for 2x12 ledger connections. Additional fasteners prohibited.
- Allowable loads shall be limited to parallel-to-grain loaded solid sawn main members (minimum 2" nominal). Wood side members shall be loaded perpendicular to grain.
- Allowable loads are shown at the wood load duration factor of  $C_D = 1.00$ . Loads may be increased for load duration as permitted by the building code up to a  $C_D = 1.60$ . All adjustment factors shall be applied per NDS. For in-service moisture content greater than nineteen percent (19%), use Wet Service Factor ( $C_M$ ) = 0.70.
- Fasteners shall be centered in the stud and spaced as shown in the pictures.
- GWB must be attached as required per the building code.
- Where designated as,  $\geq$  "Fastener Length" allowable loads per stud connection are applicable to fasteners with lengths greater than or equal to the specified length. Fastener shall not penetrate through the stud depth.



## STRONGER IN THE STORM.



## EASIER ON THE JOBSITE.

Quick Tie Products, Inc. produces a patented hold down system for wood frame and masonry construction which resists high wind and seismic forces. The system is easy to install, reducing parts needed and therefore saving time and money.



**8 PATENTED PRODUCTS**  
Quicktieproducts.com

## QR CODES

(Open your camera application to scan and view)

### CODE APPROVALS



**TER 0910-01**  
(QuickTie™ Systems-Wood & QuickTie™ Connectors)



**TER 1811-03**  
(QuickTie™ U-Hanger Series)

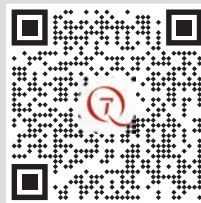

**TER 1404-06**  
(QuickTie™ Systems-Masonry)

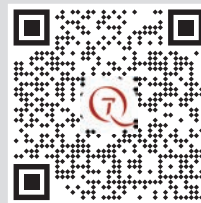

**TER 1506-20**  
(QuickTie™ Systems-Portal Frame)



**ESR-4467**  
(QE-1 Adhesive Anchoring System)

### INSTALLATION VIDEOS



**SPArTan™ Installation**



**Form Tie Installation**



**Wood Frame Installation**



**Masonry Installation**

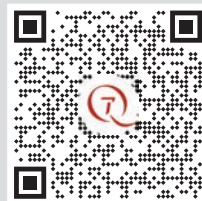

**Column Installation**



**At Mexico Beach, FL**

### HURRICANE MICHAEL

We Sell  
**NATIONWIDE**

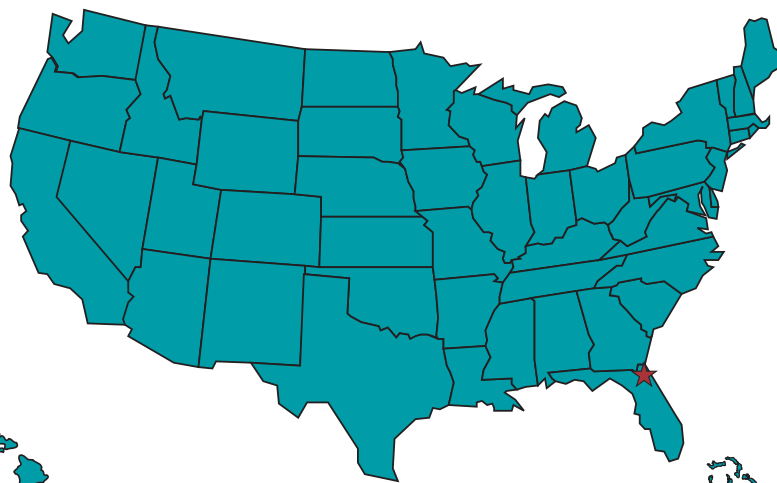

★ HEADQUARTERS  
■ PROJECTS



**Quick Tie Products, Inc.**  
quicktie.com

**MAIN OFFICE:**  
13300 Vantage Way  
Jacksonville, FL 32218  
Phone: (904) 281-0525  
To Order: orders@quicktieproducts.com

©Copyright 2026 Quick Tie Products, Inc.  
Rev. 4/14/26

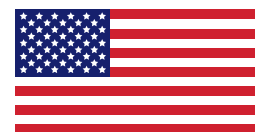

**MADE IN USA\***